



### **IABU Headquarters**

**Delta Electronics, Inc.**  
Taoyuan3  
No.18, Xinglong Rd., Taoyuan City,  
Taoyuan County 330, Taiwan, R.O.C.  
TEL: 886-3-362-6301 / FAX: 886-3-371-6301

### **Asia**

**Delta Electronics (Jiangsu) Ltd.**  
Wujiang Plant3  
1688 Jiangxing East Road,  
Wujiang Economic Development Zone  
Wujiang City, Jiang Su Province,  
People's Republic of China (Post code: 215200)  
TEL: 86-512-6340-3008 / FAX: 86-769-6340-7290

**Delta Greentech (China) Co., Ltd.**  
238 Min-Xia Road, Cao-Lu Industry Zone, Pudong, Shanghai,  
People's Republic of China  
Post code : 201209  
TEL: 021-58635678 / FAX: 021-58630003

**Delta Electronics (Japan), Inc.**  
Tokyo Office  
2-1-14 Minato-ku Shibadaimon,  
Tokyo 105-0012, Japan  
TEL: 81-3-5733-1111 / FAX: 81-3-5733-1211

**Delta Electronics (Korea), Inc.**  
234-9, Duck Soo Building 7F, Nonhyun-Dong,  
Kangnam-Gu, Seoul, Korea 135-010  
TEL: 82-2-515-5305 / FAX: 82-2-515-5302

**Delta Electronics Int'l (S) Pte Ltd**  
4 Kaki Bukit Ave 1, #05-05, Singapore 417939  
TEL: 65-6747-5155 / FAX: 65-6744-9228

**Delta Electronics (India) Pvt. Ltd.**  
Plot No. 43, Sector – 35, HSIIDC,  
Gurgaon122001, Haryana, India  
TEL: 1-919-767-3800 / FAX: 91-124-403-6045

### **Americas**

**Delta Products Corporation (USA)**  
Raleigh Office  
P.O. Box 12173, 5101 Davis Drive,  
Research Triangle Park, NC 27709, U.S.A.  
TEL: 1-919-767-3813 / FAX: 1-919-767-3969

**Delta Greentech (Brasil) S.A**  
Sao Paulo Office  
Rua Itapeva, 26-30 Andar Edificio Itapeva One-Bela Vista  
01332-000-Sao Paulo-SP-Brazil  
TEL: +55 11 3568-3850/FAX: +55 11 3568-3865

### **Europe**

**Deltronics (The Netherlands) B.V.**  
Eindhoven Office  
De Witbogt 15, 5652 AG Eindhoven, The Netherlands  
TEL: 31-40-2592850 / FAX: 31-40-2592851

V5.1  
DELTA\_IA-ASDA\_A2\_UM\_EN\_20170209

\*We reserve the right to change the information in this manual without prior notice.

Delta High Resolution AC Servo Drive for Network Communication Applications ASDA-A2 Series User Manual



## **Delta High Resolution AC Servo Drive for Network Communication Applications ASDA-A2 Series User Manual**

[www.delta.com.tw/ia](http://www.delta.com.tw/ia)



# Preface

---

Thank you for purchasing ASDA-A2. This user manual provides the related information of ASDA-A2R series servo drive and ECMA series servo motors. This manual includes:

- Installation and inspection of servo drive and servo motor
- The configuration of servo drive
- Procedures of trial run
- Control function and adjustment methods of servo drive
- Parameters
- Communication protocol
- Maintenance and inspections
- Troubleshooting

This manual addresses personnel with the following qualifications:

- Servo system designers
- Installation or wiring personnel
- Trial and tuning personnel
- Maintenance and inspection personnel

Before using the product, please read through this manual carefully in order to ensure the correct use of the product. In addition, please place this manual safely for quick reference whenever is needed. Please follow the rules below if you have not finished reading this manual yet.

- No water, corrosive gas and inflammable gas are allowed in installation environment.
- Three-phase power is prohibited to connect to U, V and W connector when wiring. It is possible to damage the servo drive.
- Ground is a must.
- Do not disconnect the servo drive, motor or change the wiring when connecting to the power.
- Be ensured that the emergency stop can be activated anytime before connecting to the power and operation.
- Do not touch the heat sink to avoid scald before connecting to the power and operation.

If you have any enquiry, please contact the distributors or DEALTA customer service center.

## Safety Precautions

ASDA-A2 series is the high resolution and open type servo drive. It should be installed in a shielded control box during operation. This servo drive uses precise feedback control and the digital signal processor with high-speed calculation function to control the current output which generated by IGBT so as to operate three-phase permanent magnet synchronous motors (PMSM) and to achieve precise positioning.

ASDA-A2 is applicable on industrial application and is suggested to be installed in the panel-board of the user manual. (Servo drives, wire rod and motors all should be installed in the environment which complies with the minimum requirement of UL Level 1.)

Pay special attention to the following safety precautions anytime during inspection, installation, wiring, operation and examination.

The symbol of **danger**, **warning** and **stop** represent:



It indicates the potential hazards. It is possible to cause severe injury or fatal harm if not follow the instructions.



It indicates the potential hazards. It is possible to cause minor injury or lead to serious damage of the product or even malfunction if not follow the instructions.



It indicates the absolute prohibited activity. It is possible to damage the product or cannot be used due to malfunction if not follow the instructions.

### Inspection



- Please follow the instruction when using servo drive and servo motor, or it is possible to cause fire or malfunction.

### Installation



- It is prohibited to expose the product with the environment which containing water, corrosive gas, inflammable gas, etc. Or it is possible to cause electric shock or fire.

### Wiring



- Please connect the ground terminal to class-3 ground system (under 100 Ω); poor grounding may result in electric shock or fire.
- Do not connect the three-phase source to the motor output terminal U, V and W. Or it is possible to cause personnel injury or fire.
- Please tighten the screws of the power and motor output terminal. Or it is possible to cause fire.
- Please connect wiring according to the wire rod in order to prevent any danger.

## Operation



- Before the operation, please change the parameter setting value according to the needs. If it is not adjusted to the correct setting value, it is possible to lead to malfunction of the machine or the operation might out of control.
- Before the machine starts to operate, please be ensured the emergency stop can be activated anytime.
- When power on, please make sure the motor shaft stands still and will not operate because of mechanical inertia or other causes.



- During the operation, it is prohibited to touch any rotating motor parts. Or it is possible to cause personnel injury.



- In order to prevent any accident, please separate the couplings and belts of the machine and isolate them. Then conduct the initial trial run.
- If users fail to operate the machine properly after the servo motor connects to the equipment, it would cause the damage of the equipment and lead to the personnel injury.
- In order to prevent the danger, it is strongly recommended to check if the motor can operate normally without load first. Then, operate the motor with load.
- Do not touch the heat sink of the servo drive. Or it is possible to cause scald due to the high temperature.

## Maintenance and Inspection



- It is prohibited to touch the internal parts of the servo drive and servo motor. Or it is possible to cause electric shock.
- It is prohibited to disassemble the panel of the servo drive when turning on the power. Or it is possible to cause electric shock.
- Do not touch the ground terminal within 10 minutes after turning off the power. Or the residual voltage may cause electric shock.
- Do not disassemble the motor. Or it is possible to cause electric shock or personnel injury.
- Do not change the wiring when the power is on. Or it is possible to cause electric shock or personnel injury.
- Only the qualified electrical and electronics professionals can install, wire and maintain the servo drive and servo motor.

## Main Circuit Wiring



- Do not put the power cable and the encoder cable in the same channel and bond them together. Please separate the power cable and the encoder cable for at least 30 centimeters (= 11.8 inches) when wiring.
- Please use stranded wires and multi-core shielded-pair wires for the encoder cables and encoder feedback cables. The maximum length of command input cable is 3 meters (= 9.84 feet) and the maximum length of feedback cable is 20 meters (= 65.62 feet).
- The high voltage might remain in the servo motor even when the power is off. Do not touch the power terminal temporarily (at least 10 minutes). Please conduct the inspection not until the indicator light, **CHARGE** is off.



- Do not turn the power on and off too often. If continuous power on and off is needed, please be ensured the interval is one minute at most.

## Terminal Wiring of the Main Circuit



- When wiring, please disassemble the terminal socket from the servo drive.
- One terminal of the terminal socket for one electric wire only.
- When inserting the electric wires, do not connect the conductor to the adjacent wire.
- Before connecting to the power, please inspect and be ensured the wiring is correct.



### NOTE

If there is any difference of each version, please refer to DELTA's website (<http://www.delta.com.tw/industrialautomation/>) for the latest information.

# Table of Contents

---

<b>Chapter 1</b>	<b>Inspection and Model Explanation</b>	<b>1-1</b>
1.1	Inspection	1-1
1.2	Product Model	1-3
1.2.1	Nameplate Information	1-3
1.2.2	Model Explanation	1-4
1.3	Servo Drive and Corresponding Servo Motor	1-6
1.3.1	220 V Series	1-6
1.3.2	400 V Series	1-8
1.4	Each Part of the Servo Drive	1-9
1.4.1	220 V Series	1-9
1.4.2	400 V Series	1-12
<b>Chapter 2</b>	<b>Installation</b>	<b>2-1</b>
2.1	Notes	2-1
2.2	Ambient Conditions of Storage	2-1
2.3	Ambient Conditions of Installation	2-1
2.4	Installation Direction and Space	2-2
2.5	Specification of Circuit Breaker and Fuse	2-5
2.6	EMI Filter Selection	2-6
2.7	Selection of Regenerative Resistor	2-9
<b>Chapter 3</b>	<b>Wiring</b>	<b>3-1</b>
3.1	Connections – 220V series	3-1
3.1.1	Connecting to Peripheral Devices	3-1

3.1.2	Connectors and Terminals of Servo Drive.....	3-2
3.1.3	Wiring Method .....	3-4
3.1.4	Specification of Motor Power Cable .....	3-6
3.1.5	Specification of Encoder Cable Connector.....	3-8
3.1.6	Selection of Wiring Rod.....	3-12
3.2	Connections – 400V series .....	3-14
3.2.1	Connecting to Peripheral Devices .....	3-14
3.2.2	Connectors and Terminals of the Servo Drive.....	3-16
3.2.3	Wiring Method .....	3-18
3.2.4	Specification of Motor Power Cable .....	3-19
3.2.5	Specification of Encoder Connector .....	3-21
3.2.6	Selection of Wiring Rod.....	3-23
3.3	Basic Wiring .....	3-25
3.3.1	220V series .....	3-25
3.3.2	400V series .....	3-28
3.4	I/O Signal (CN1) Connection.....	3-30
3.4.1	I/O Signal (CN1) Connector Terminal Layout.....	3-30
3.4.2	Signals Explanation of Connector CN1 .....	3-32
3.4.3	Wiring Diagrams (CN1) .....	3-42
3.4.4	DI and DO Signal Specified by Users.....	3-50
3.4.5	Application: Using CN1 Quick Connector for Wiring .....	3-50
3.5	CN2 Connector.....	3-54
3.6	Wiring of CN3 Connector .....	3-57
3.6.1	Layout of CN3 Connector.....	3-57
3.6.2	Connection between PC and Connector CN3.....	3-58

3.7	CN4 Serial Connector (USB).....	3-59
3.8	CN5 Connector (Full-closed loop).....	3-60
3.9	CN6 Connector (CANopen).....	3-61
3.10	Extension Digital Input Connector of CN7.....	3-63
3.11	CN8 Connector of Battery Box.....	3-64
3.12	Standard Connection Example – 220V series.....	3-65
3.12.1	Position (PT) Control Mode.....	3-65
3.12.2	Position (PR) Control Mode.....	3-66
3.12.3	Speed Control Mode.....	3-67
3.12.4	Torque Control Mode.....	3-68
3.12.5	Communication Mode.....	3-69
3.13	Standard Connection Example – 400V series.....	3-70
3.13.1	Position (PT) Control Mode.....	3-70
3.13.2	Position (PR) Control Mode.....	3-71
3.13.3	Speed Control Mode.....	3-72
3.13.4	Torque Control Mode.....	3-73
3.13.5	Communication Mode.....	3-74
<b>Chapter 4</b>	<b>Panel Display and Operation.....</b>	<b>4-1</b>
4.1	Panel Description.....	4-1
4.2	Parameter Setting Procedure.....	4-2
4.3	Status Display.....	4-5
4.3.1	Save Setting Display.....	4-5
4.3.2	Decimal Point.....	4-5
4.3.3	Alarm Message.....	4-5
4.3.4	Positive and Negative Sign Setting.....	4-5



4.3.5	Monitor Display .....	4-6
4.4	General Function .....	4-9
4.4.1	Operation of Fault Record Display .....	4-9
4.4.2	JOG Mode .....	4-10
4.4.3	Force DO Output .....	4-11
4.4.4	Digital Input Diagnosis Operation .....	4-12
4.4.5	Digital Output Diagnosis Operation .....	4-12
<b>Chapter 5</b>	<b>Trial Operation and Tuning .....</b>	<b>5-1</b>
5.1	Inspection without Load.....	5-1
5.2	Applying Power to the Servo Drive.....	5-2
5.3	JOG Trial Run without Load .....	5-6
5.4	Trial Run without Load (Speed Mode).....	5-7
5.5	Trial Run without Load (Position Mode) .....	5-9
5.6	Tuning Procedure.....	5-11
5.6.1	Flowchart of Tuning Procedure .....	5-12
5.6.2	Inertia Estimation Flowchart (with Mechanism).....	5-13
5.6.3	Flowchart of Auto Tuning .....	5-14
5.6.4	Flowchart of Semi-Auto Tuning .....	5-15
5.6.5	Limit of Inertia Ratio .....	5-16
5.6.6	Mechanical Resonance Suppression Method .....	5-18
5.6.7	Tuning Mode and Parameters.....	5-19
5.6.8	Tuning in Manual Mode.....	5-20
<b>Chapter 6</b>	<b>Control Mode of Operation.....</b>	<b>6-1</b>
6.1	Selection of Operation Mode.....	6-1
6.2	Position Mode.....	6-3

6.2.1	Position Command in PT Mode .....	6-3
6.2.2	Position Command in PR Mode .....	6-7
6.2.3	Control Structure of Position Mode.....	6-8
6.2.4	S-curve Filter (Position).....	6-9
6.2.5	Electronic Gear Ratio .....	6-12
6.2.6	Low-pass Filter .....	6-15
6.2.7	Timing Diagram in Position Mode (PR).....	6-16
6.2.8	Gain Adjustment of Position Loop .....	6-17
6.2.9	Low-frequency Vibration Suppression in Position Mode .....	6-19
6.3	Speed Mode .....	6-24
6.3.1	Selection of Speed Mode .....	6-24
6.3.2	Control Structure of Speed Mode.....	6-25
6.3.3	Smooth Speed Command .....	6-26
6.3.4	The Scaling of Analog Command.....	6-30
6.3.5	Timing Diagram in Speed Mode .....	6-31
6.3.6	Gain Adjustment of Speed Loop .....	6-31
6.3.7	Resonance Suppression .....	6-38
6.4	Torque Mode .....	6-45
6.4.1	Selection of Torque Command.....	6-45
6.4.2	Control Structure of Torque Mode.....	6-46
6.4.3	Smooth Torque Command .....	6-47
6.4.4	The Scaling of Analog Command.....	6-47
6.4.5	Timing Diagram in Torque Mode .....	6-48
6.5	Dual Mode .....	6-49
6.5.1	Speed / Position Dual Mode.....	6-50

6.5.2	Speed / Torque Dual Mode .....	6-50
6.5.3	Torque / Position Dual Mode .....	6-51
6.6	Others.....	6-52
6.6.1	The Use of Speed Limit.....	6-52
6.6.2	The Use of Torque Limit.....	6-52
6.6.3	Analog Monitor .....	6-53
6.6.4	The Use of Brake .....	6-57
<b>Chapter 7</b>	<b>Motion Control.....</b>	<b>7-1</b>
7.1	Motion Control Functions of ASDA-A2 .....	7-1
7.2	System Information .....	7-1
7.2.1	Description of Monitoring Variables.....	7-2
7.2.2	Description of Data Array .....	7-8
7.3	Description of Motion Axes.....	7-11
7.4	Description of PR Mode .....	7-12
7.5	The Difference between General PR Mode and the One in ASDA-A2 .....	7-12
7.6	The Position Unit of PR Mode .....	7-13
7.7	Description of Register in PR Mode .....	7-13
7.8	Homing Description of PR Mode .....	7-15
7.9	DI/DO Provided by PR Mode and Diagrams .....	7-16
7.10	Parameter Settings.....	7-18
7.10.1	The Relation between the Previous Path and the Next Path .....	7-25
7.10.2	Programming the Path in PR Mode.....	7-26
7.11	The Description of E-Cam Function .....	7-27
7.11.1	Function Description of CAPTURE (Data Capture).....	7-34
7.11.2	Function Description of COMPARE (Data Compare).....	7-36

<b>Chapter 8 Parameters</b> .....	<b>8-1</b>
8.1 Parameter Definition.....	8-1
8.2 List of Parameters .....	8-2
8.3 Parameter Description.....	8-13
P0-xx Monitor Parameters .....	8-13
P1-xx Basic Parameters .....	8-40
P2-xx Extension Parameters .....	8-91
P3-xx Communication Parameters .....	8-136
P4-xx Diagnosis Parameters .....	8-147
P5-xx Motion Setting Parameters .....	8-161
P6-xx PR Parameters .....	8-225
P7-xx PR Parameters .....	8-267
Table 8.1 Function Description of Digital Input (DI) .....	8-279
Table 8.2 Function Description of Digital Output (DO).....	8-288
<b>Chapter 9 Communications</b> .....	<b>9-1</b>
9.1 RS-485 & RS-232 Communication Hardware Interface .....	9-1
9.2 RS-485 & RS-232 Communication Parameters Setting.....	9-3
9.3 MODBUS Communication Protocol .....	9-6
9.4 Write-in and Read-out Communication Parameters.....	9-18
<b>Chapter 10 Troubleshooting</b> .....	<b>10-1</b>
10.1 Alarm of Servo Drive .....	10-1
10.2 Alarm of CANopen Communication .....	10-5
10.3 Alarm of Motion Control.....	10-7
10.4 Causes and Corrective Actions .....	10-10
10.5 Corrective Actions after the Alarm Occurs .....	10-29

<b>Chapter 11</b>	<b>Specifications</b>	<b>11-1</b>
11.1	Specifications of Servo Drives	11-1
11.1.1	ASDA-A2 220V Series	11-1
11.1.2	ASDA-A2 400V Series	11-4
11.2	Specifications of Servo Motors (ECMA Series)	11-7
11.2.1	ECMA 220V Series	11-7
11.2.2	ECMA 400V Series	11-17
11.3	Torque Features (T-N Curves)	11-25
11.3.1	220V Series	11-25
11.3.2	400V Series	11-27
11.4	Overload Features	11-29
11.5	Dimensions of Servo Drive	11-31
11.5.1	220V Series	11-31
11.5.2	400V Series	11-38
11.6	Dimensions of Servo Motor (ECMA Series)	11-41
11.6.1	220V Series	11-41
11.6.2	400V Series	11-48
<b>Chapter 12</b>	<b>Absolute System</b>	<b>12-1</b>
12.1	Backup Battery Boxes	12-2
12.1.1	Specifications	12-2
12.1.2	Battery Box Dimensions	12-4
12.1.3	Connection Cables for Absolute Encoder	12-5
12.1.4	Battery Box Cords	12-7
12.2	Installation	12-8
12.2.1	Connection Examples	12-8

12.2.2	How to Install a Battery.....	12-12
12.2.3	How to Replace a Battery.....	12-13
12.3	System Initialization Procedure and Operation .....	12-15
12.3.1	System Initialization Procedure .....	12-15
12.3.2	Pulse Counting .....	12-16
12.3.3	PUU Counting.....	12-17
12.3.4	Use Digital Inputs/Outputs to Initialize an Absolute System.....	12-18
12.3.5	Use Parameters to Initialize an Absolute System.....	12-18
12.3.6	Use Digital Inputs/Outputs to Read the Absolute Coordinate Data .....	12-19
12.3.7	Use Parameter to Read the Absolute Coordinate Data.....	12-23
12.4	Related Parameters for Absolute System .....	12-24
12.5	Digital Input (DI) Function Definition (for Absolute System) .....	12-30
12.6	Digital Output (DO) Function Definition (for Absolute System) .....	12-31
12.7	Alarms for Absolute System .....	12-32
12.7.1	Causes and Corrective Actions .....	12-33
12.8	Related Monitoring Variables .....	12-35
<b>Appendix A</b>	<b>Accessories .....</b>	<b>A-1</b>
<b>Appendix B</b>	<b>Maintenance and Inspection .....</b>	<b>B-1</b>

## About this Manual

### User Information

Be sure to store this manual in a safe place.

Due to constantly growing product range, technical improvement and alteration or changed texts, figures and diagrams, we reserve the right of this manual contained information change without prior notice.

Coping or reproducing any part of this manual, without written consent of Delta Electronics Inc. is prohibited.

### Technical Support and Service

Welcome to contact us or visit our web site (<http://www.delta.com.tw/ia/>) if you need any technical support, service and information, or, if you have any question in using the product. We are looking forward to serve you needs and willing to offer our best support and service to you. Reach us by the following ways.

#### ASIA

DELTA ELECTRONICS, INC.  
Taoyuan Plant 1  
31-1, XINGBANG ROAD,  
GUISHAN INDUSTRIAL ZONE,  
TAOYUAN COUNTY 33370, TAIWAN, R.O.C.  
TEL: 886-3-362-6301  
FAX: 886-3-362-7267

#### JAPAN

DELTA ELECTRONICS (JAPAN), INC.  
Tokyo Office  
DELTA SHIBADAIMON BUILDING  
2-1-14 SHIBADAIMON, MINATO-KU,  
TOKYO, 105-0012, JAPAN  
TEL: 81-3-5733-1111  
FAX: 81-3-5733-1211

#### NORTH/SOUTH AMERICA

DELTA PRODUCTS CORPORATION (USA)  
Raleigh Office  
P.O. BOX 12173  
5101 DAVIS DRIVE,  
RESEARCH TRIANGLE PARK, NC 27709,  
U.S.A.  
TEL: 1-919-767-3813  
FAX: 1-919-767-3969

#### EUROPE

DELTRONICS (THE NETHERLANDS) B.V.  
Eindhoven Office  
DE WITBOGT 15, 5652 AG EINDHOVEN,  
THE NETHERLANDS  
TEL: 31-40-259-2850  
FAX: 31-40-259-2851

# Chapter 1 Inspection and Model

## Explanation

---

### 1.1 Inspection

In order to prevent the negligence during purchasing and delivery, please inspect the following items carefully.

- Please check if the product is what you have purchased: check the part number of the motor and the servo drive on the nameplate. Refer to the next page for the model explanation.
- Check if the motor shaft can rotate smoothly: Rotate the motor shaft by hand. If it can be rotated smoothly, it means the motor shaft is normal. However, it cannot be rotated by hand if the motor has an electromagnetic brake.
- Check if there is any damage shown on its appearance: visually check if there is any damage or scrape of the appearance.
- Check if there is any loose screw: If the screws are un-tightened or fall off.

If any of the above situations happens, please contact the distributors to solve the problems.

A complete and workable servo set should include:

- (1) A Servo drive and a servo motor
- (2) A UVW motor power cable, the U, V and W wires can connect to the socket attached by the servo drive and another side is the plug which could connect to the socket of the motor. And a green ground wire which should be locked to the ground terminal of the servo drive. (selective purchase)
- (3) An encoder cable which connects to the socket of the encoder. One side of it connects to CN2 servo drive and another side is the plug. (selective purchase)
- (4) 50-PIN connector which is used in CN1 (selective purchase)
- (5) 20-PIN connector which is used in CN2 (selective purchase)
- (6) 6-PIN connector which is used in CN3 and is for general communication (RS-485) (selective purchase)
- (7) 4-PIN connector which used in CN4 (USB Type B product) (selective purchase)
- (8) RJ45 connector which used in CN6 and is for high-speed communication (selective purchase)
- (9) 7-PIN connector which used in CN7, for extension DI. (-U model) (selective purchase)



(10) Servo drive power input:

220V:

	Control circuit power	Main circuit power
100 W ~ 3 kW	L1c, L2C, ⊖ fast connector	R, S, T fast connector
405 kW ~ 15 kW	L1c, L2C, ⊖ terminal block	R, S, T terminal block

400V:

	Control circuit power	Main circuit power
750 W ~ 1.5 kW	DC24V, DC0V, ⊖ fast connector	R, S, T fast connector
2 kW ~ 7.5 kW	DC24V, DC0V, ⊖ terminal block	R, S, T terminal block

(11) 3-PIN fast connector (U, V, W)

(12) 3-PIN fast connector (P<sup>⊕</sup>, D, C)

(13) A plastic lever (for 220V 100 W ~ 3 kW and 400V 750 W ~ 1.5 kW)

(14) A metal short-circuit chip (for 220 V 100 W ~ 4.5 kW and 400 V 750 W ~ 1.5 kW)

(15) An installation manual

## 1.2 Product Model

### 1.2.1 Nameplate Information

#### ASDA-A2 Series Servo Drive

■ Nameplate Information

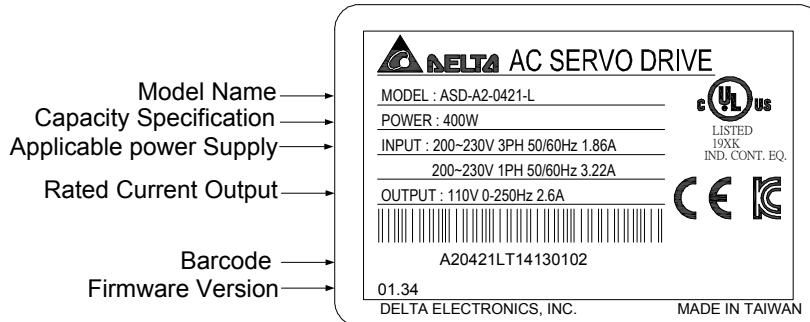

■ Serial Number

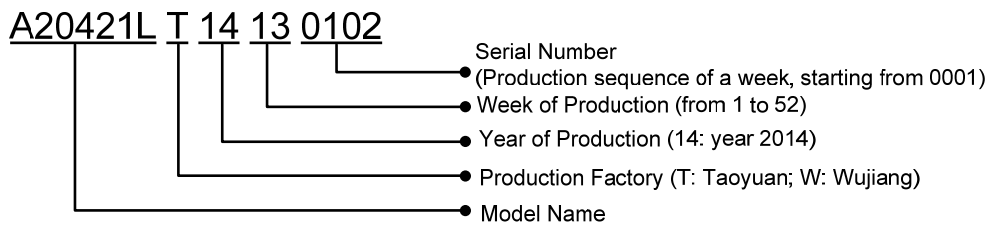

#### ECMA Series Servo Motor

■ Nameplate Information

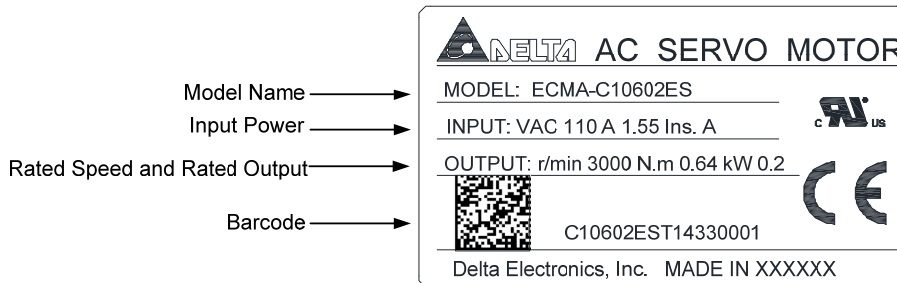

■ Serial Number

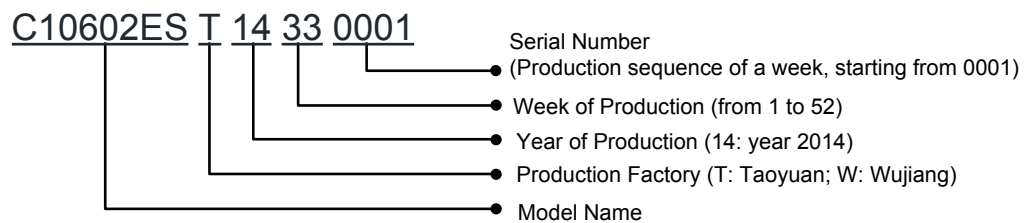

### 1.2.2 Model Explanation

#### ASDA-A2 Series Servo Drive

**A S D - A 2 - 0 7 4 3 - U**

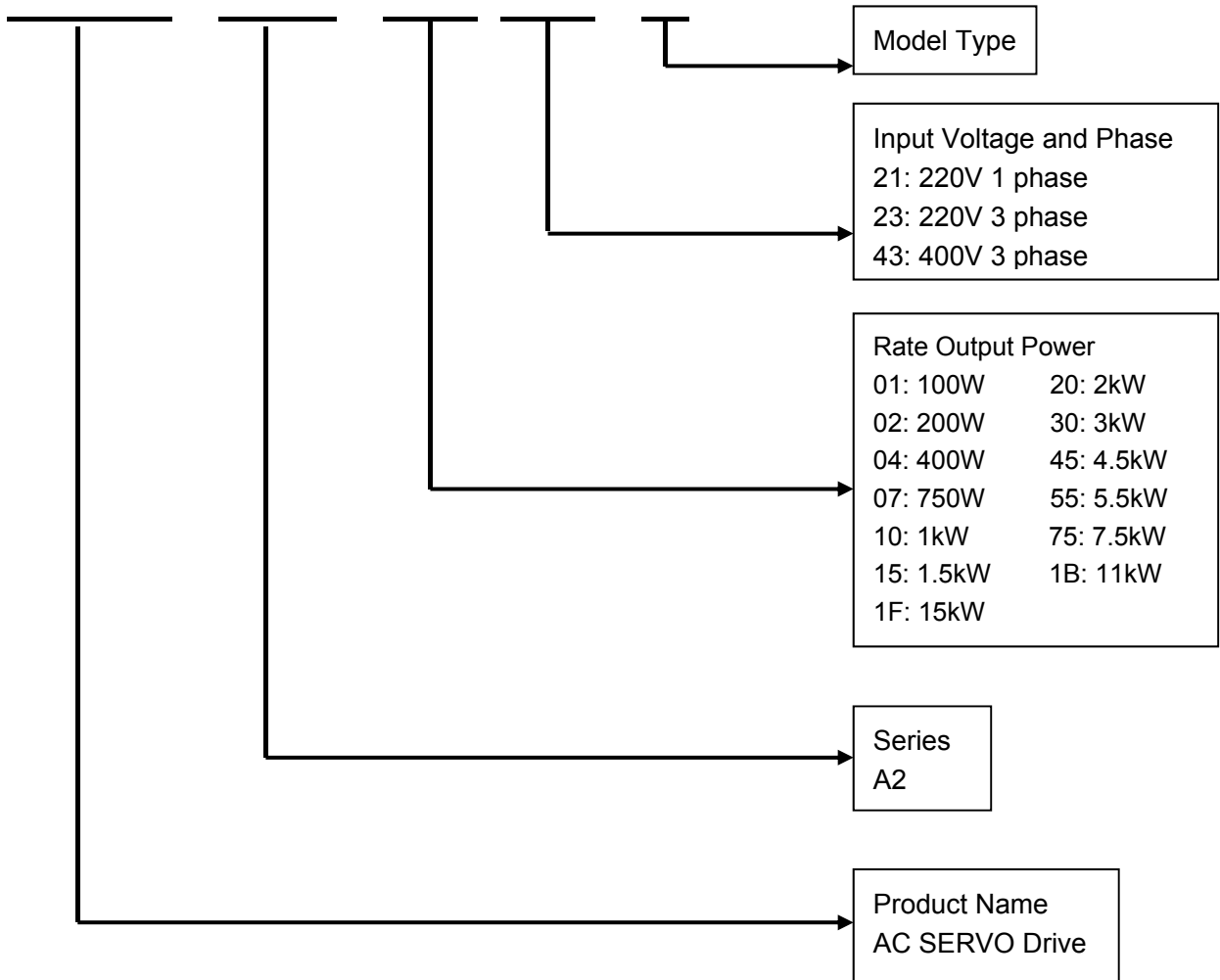

#### Model Type

	Type	RS-485 (CN3)	Full-closed control (CN5)*1	Extension Port for Digital Input (CN7)	EtherCAT	CANopen	DMCNET	Analog Voltage Control	Pulse Input Port	PR Mode*2	E-Cam*3
Standard Model	L	O	O	X	X	X	X	O	O	O	X
	U	O	O	O	X	X	X	O	O	O	O
Network Model	E	X	O	O	O	X	X	X	X	O	O
	F	O	O	X	X	X	O	X	X	O	X
	M	O	O	X	X	O	X	O	O	O	O

**NOTE**

1. In PR mode, only A2-F supports full-closed control function.
2. PR parameters can be read and written through communication by DMCNET only.
3. E-cam function can only be used in PR mode.

ECMA Series Servo Motor

**E C M A - C 1 0 6 0 2 E S**

Standard Shaft Diameter: S  
 Specific Shaft Diameter: 3=42mm, 7=14mm

Type of Shaft Diameter and Oil Seal	w/o Brake, w/o Oil Seal	with Brake, w/o Oil Seal	w/o Brake, with Oil Seal	With Brake, with Oil Seal
Round Shaft (with fixed screw holes)	-	-	C	D
Keyway	E	F	-	-
Keyway (with fixed screw holes)	P	Q	R	S

Rated Power Output  
 0F:50W 09:900W 50:5.0kW  
 01:100W 10:1.0kW 55:5.5kW  
 02:200W 13:1.3kW 75:7.5kW  
 03:300W 15:1.5kW 1B:11kW  
 04:400W 18:1.8kW 1F:15kW  
 05:500W 20:2.0kW  
 06:600W 30:3.0kW  
 07:750W 35:3.5kW  
 08:850W 45:4.5kW

Motor Frame Size  
 04:40mm 09:86mm 18:180mm  
 06:60mm 10:100mm 22:220mm  
 08:80mm 13:130mm

Name of the Series  
 Rated Voltage and Rated Speed  
**C** = 220V/3,000 rpm; **E** = 220V/2,000 rpm;  
**F** = 220V/1,500 rpm; **G** = 220V/1,000 rpm;  
**J** = 400V/3,000 rpm; **K** = 400V/2,000 rpm;  
**L** = 400V/1,500 rpm; **M** = 400V/1,000 rpm  
 Encoder Type  
 1: Incremental, 20-bit  
 2: Incremental, 17-bit  
 3: 2500 ppr  
 A: Absolute (Resolution of single cycle: 17-bit; Resolution of multi-cycle: 16-bit)

Servo Type  
 A: AC Servo

Product Name  
 ECM: Electronic Commutation Motor

## 1.3 Servo Drive and Corresponding Servo Motor

### 1.3.1 220V Series

		Motor				Servo Drive			
Motor series	Power	Output (W)	Model Number	Rated Current (Arms)	Max. Instantaneous current (A)	Model Number	Continuous Output Current (Arms)	Max. Instantaneous output current (A)	
Low Inertia	ECMA-C 3000 r/min	Single- /Three- phase	50	ECMA-C1040F□S	0.69	2.05	ASD-A2-0121-□	0.90	2.70
			100	ECMA-C△0401□S	0.90	2.70			
			200	ECMA-C△0602□S	1.55	4.65	ASD-A2-0221-□	1.55	4.65
			400	ECMA-C△0604□S	2.60	7.80	ASD-A2-0421-□	2.60	7.80
			400	ECMA-C△0804□7	2.60	7.80			
			750	ECMA-C△0807□S	5.10	15.30	ASD-A2-0721-□	5.10	15.30
			750	ECMA-C△0907□S	3.66	11.00			
			1000	ECMA-C△0910□S	4.25	12.37	ASD-A2-1021-□	7.30	21.90
			1000	ECMA-C△1010□S	7.30	21.90			
			2000	ECMA-C△1020□S	12.05	36.15	ASD-A2-2023-□	13.40	40.20
			3000	ECMA-C△1330□4	17.2	47.5	ASD-A2-3023-□	19.40	58.20
Medium Inertia	ECMA-E 2000 r/min	Single- /Three- phase	500	ECMA-E△1305□S	2.90	8.70	ASD-A2-0421-□	2.60	7.80
			1000	ECMA-E△1310□S	5.60	16.80	ASD-A2-1021-□	7.30	21.90
			1500	ECMA-E△1315□S	8.30	24.90	ASD-A2-1521-□	8.30	24.90
			2000	ECMA-E△1320□S	11.01	33.03	ASD-A2-2023-□	13.40	40.20
			2000	ECMA-E△1820□S	11.22	33.66			
			3000	ECMA-E△1830□S	16.10	48.30	ASD-A2-3023-□	19.40	58.20
			3500	ECMA-E△1835□S	19.20	57.60			
Medium-high inertia	ECMA-F 1500 r/min	Single- /Three- phase	500	ECMA-F△1305□S	3.90	12.10	ASD-A2-0721-□	5.10	15.30
			850	ECMA-F△1308□S	7.10	19.40	ASD-A2-1021-□	7.30	21.90
			1300	ECMA-F△1313□S	12.60	38.60	ASD-A2-2023-□	13.40	40.20
			1800	ECMA-F△1318□S	13.00	36.00			
			3000	ECMA-F△1830□S	19.40	58.20	ASD-A2-3023-□	19.40	58.20
			4500	ECMA-F△1845□S	32.50	81.30	ASD-A2-4523-□	32.50	--
			5500	ECMA-F△1855□3	40.00	100.00	ASD-A2-5523-□	40.00	--
			7500	ECMA-F△1875□3	47.50	118.80	ASD-A2-7523-□	47.50	--
			11000	ECMA-F1221B□3	51.80	129.50	ASD-A2-1B23-□	54.40	--
			15000	ECMA-F1221F□S	61.50	145.70	ASD-A2-1F23-□	70.00	--

Motor						Servo Drive		
Motor series	Power	Output (W)	Model Number	Rated Current (Arms)	Max. Instantaneous current (A)	Model Number	Continuous Output Current (Arms)	Max. Instantaneous output current (A)
High Inertia ECMA-C/G 3000 r/min	Single- /Three- phase	400	ECMA-C△0604□H	2.60	7.80	ASD-A2-0421-□	2.60	7.80
		750	ECMA-C△0807□H	5.10	15.30	ASD-A2-0721-□	5.10	15.30
		300	ECMA-G△1303□S	2.50	7.50	ASD-A2-0421-□	2.60	7.80
		600	ECMA-G△1306□S	4.80	14.40	ASD-A2-0721-□	5.10	15.30
		900	ECMA-G△1309□S	7.50	22.50	ASD-A2-1021-□	7.30	21.90

 **NOTE**

1. The boxes (□) at the ends of the servo drive model names are for optional configurations. For the actual model name, please refer to the ordering information of the actual purchased product.
2. The boxes (△) in the model names are for encoder resolution types. △= 1: Incremental type, 20-bit; △= 2: Incremental type, 17-bit; △= 3: 2500 ppr; △= A: Absolute type). The listed motor model name is for information searching, please contact to your local distributors for actual purchased product.
3. The boxes (□) in the model names represents brake or keyway oil seal.
- 4 \*11kw and 15kW will be available soon.

The above table shows the specification of servo drive which has triple rated current. For detailed specification of the servo motor and servo drive, please refer to Chapter 11.

### 1.3.2 400V Series

		Motor					Servo Drive		
Motor series	Power	Output (W)	Model Number	Rated Current (Arms)	Max. Instantaneous current (A)	Model Number	Continuous Output Current (Arms)	Max. Instantaneous output current (A)	
Low Inertia	ECMA-J 3000 r/min	Three-phase	400	ECMA-JΔ0604 S	1.62	4.85	ASD-A2-0743-□	3.07	9.21
			750	ECMA-JΔ0807 S	3.07	9.5	ASD-A2-0743-□	3.07	9.21
			750	ECMA-JΔ0907 S	2.16	6.37	ASD-A2-0743-□	3.07	9.21
			1000	ECMA-JΔ0910 S	2.4	7.17	ASD-A2-1043-□	3.52	9.86
			1000	ECMA-JΔ1010 S	4.15	12.46	ASD-A2-1543-□	5.02	10.04
			2000	ECMA-JΔ1020 S	7.09	21.28	ASD-A2-2043-□	6.66	18.65
			3000	ECMA-JΔ1330 4	9.8	29.99	ASD-A2-3043-□	11.9	33.32
Medium Inertia	ECMA-K 2000 r/min	Three-phase	750	ECMA-KΔ1305 S	1.7	5.2	ASD-A2-0743-□	3.07	9.21
			1000	ECMA-KΔ1310 S	3.52	10.56	ASD-A2-1043-□	3.52	9.86
			1500	ECMA-KΔ1315 S	5.02	15.06	ASD-A2-1543-□	5.02	10.04
			2000	ECMA-KΔ1320 S	6.66	19.98	ASD-A2-2043-□	6.66	18.65
			2000	ECMA-KΔ1820 S	6.6	19.88	ASD-A2-2043-□	6.66	18.65
Medium-high Inertia	ECMA-L 1500 r/min	Three-phase	750	ECMA-LΔ1305 S	2.1	6.1	ASD-A2-0743-□	3.07	9.21
			850	ECMA-LΔ1308 S	3.4	8.85	ASD-A2-1043-□	3.52	9.86
			1300	ECMA-LΔ1313 S	5.02	15	ASD-A2-1543-□	5.02	10.04
			3000	ECMA-LΔ1830 S	11.53	34.6	ASD-A2-3043-□	11.9	33.32
			4500	ECMA-LΔ1845 S	20.8	52	ASD-A2-4543-□	20	44
			5500	ECMA-LΔ1855 3	22.37	56	ASD-A2-5543-□	22.04	48.49
			7500	ECMA-LΔ1875 3	27.3	68.3	ASD-A2-7543-□	28.39	62.46
High Inertia	3000 r/min ECMA-G 1000	Three-phase	900	ECMA-MΔ1309 S	4.4	13.1	ASD-A2-1543-□	5.02	10.04

 **NOTE**

1. The boxes (□) at the ends of the servo drive model names are for optional configurations. For the actual model name, please refer to the ordering information of the actual purchased product.
2. The boxes (Δ) in the model names are for encoder resolution types. Δ= 1: Incremental type, 20-bit; Δ= 2: Incremental type, 17-bit; Δ= 3: 2500 ppr; Δ= A: Absolute type). The listed motor model name is for information searching, please contact to your local distributors for actual purchased product.
3. The boxes (□) in the model names represents brake or keyway oil seal.

The above table shows the specification of servo drive which has triple rated current. For detailed specification of the servo motor and servo drive, please refer to Chapter 11.

# 1.4 Each Part of the Servo Drive

## 1.4.1 220V Series

### 220V Series - Front View

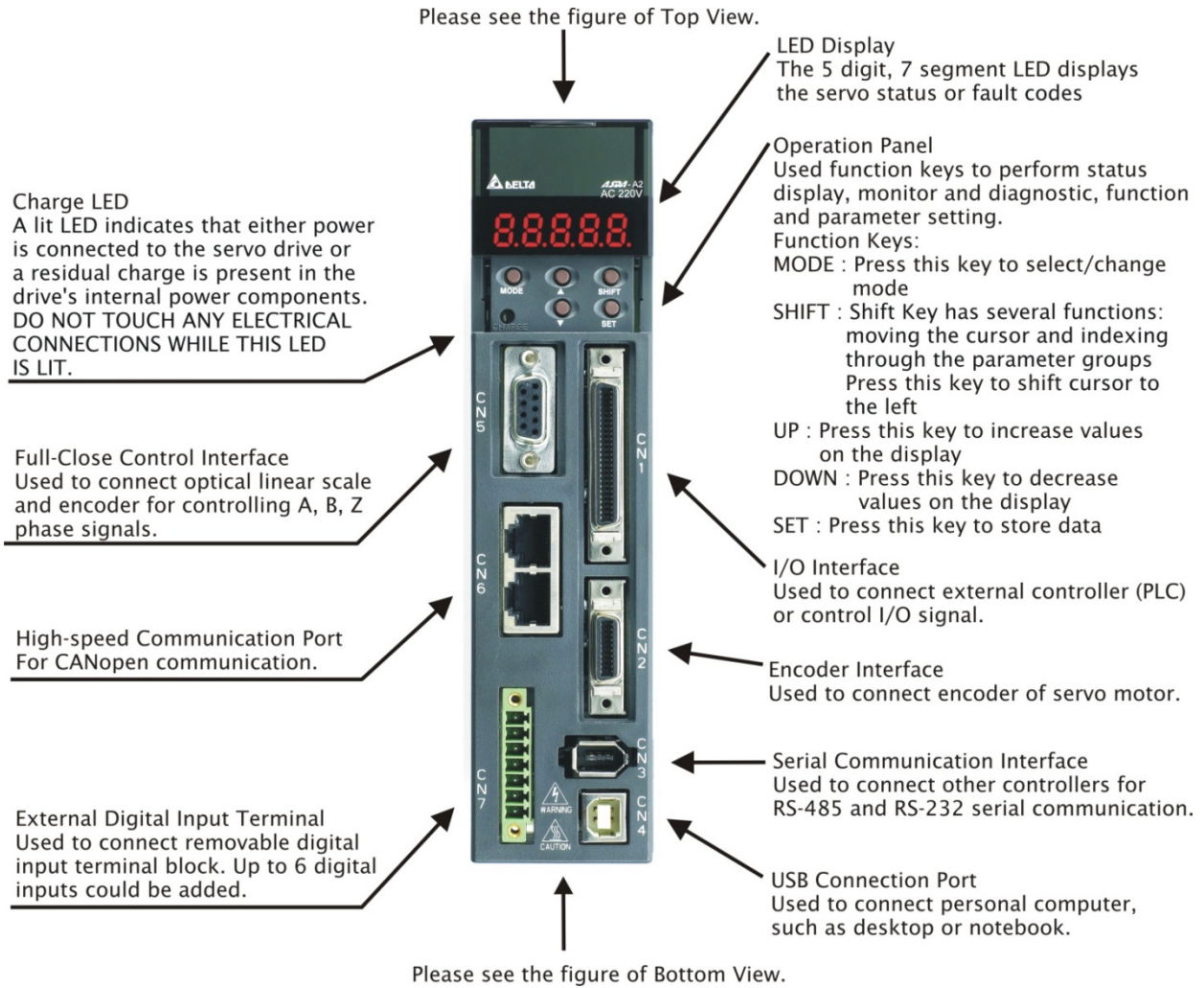



## 220V Series - Top View

Heatsink  
Used to secure servo drive  
and for heat dissipation.

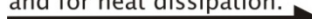
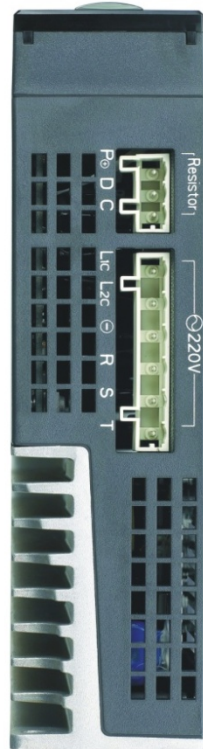
## Internal / External Regenerative Resistor Terminal

- 1) When using an external regenerative resistor, connect P<sup>+</sup> and C to the regenerative resistor and ensure that the circuit between P<sup>+</sup> and D is open.
- 2) When using the internal regenerative resistor, ensure that the circuit between P<sup>+</sup> and D is closed and the circuit between P<sup>+</sup> and C is open.
- 3) When using the external braking unit, connect the external braking unit to P<sup>+</sup> and 0. Also, ensure that the circuit between P<sup>+</sup> and D, and P<sup>+</sup> and C is open.

Control Circuit Terminal (L1c, L2c)  
Used to connect 200~230Vac, 50/60Hz  
1-phase/3-phase VAC supply.

Main Circuit Terminal (R, S, T)  
Used to connect 200~230V, 50/60Hz  
commercial power supply.

### 220V Series - Bottom View

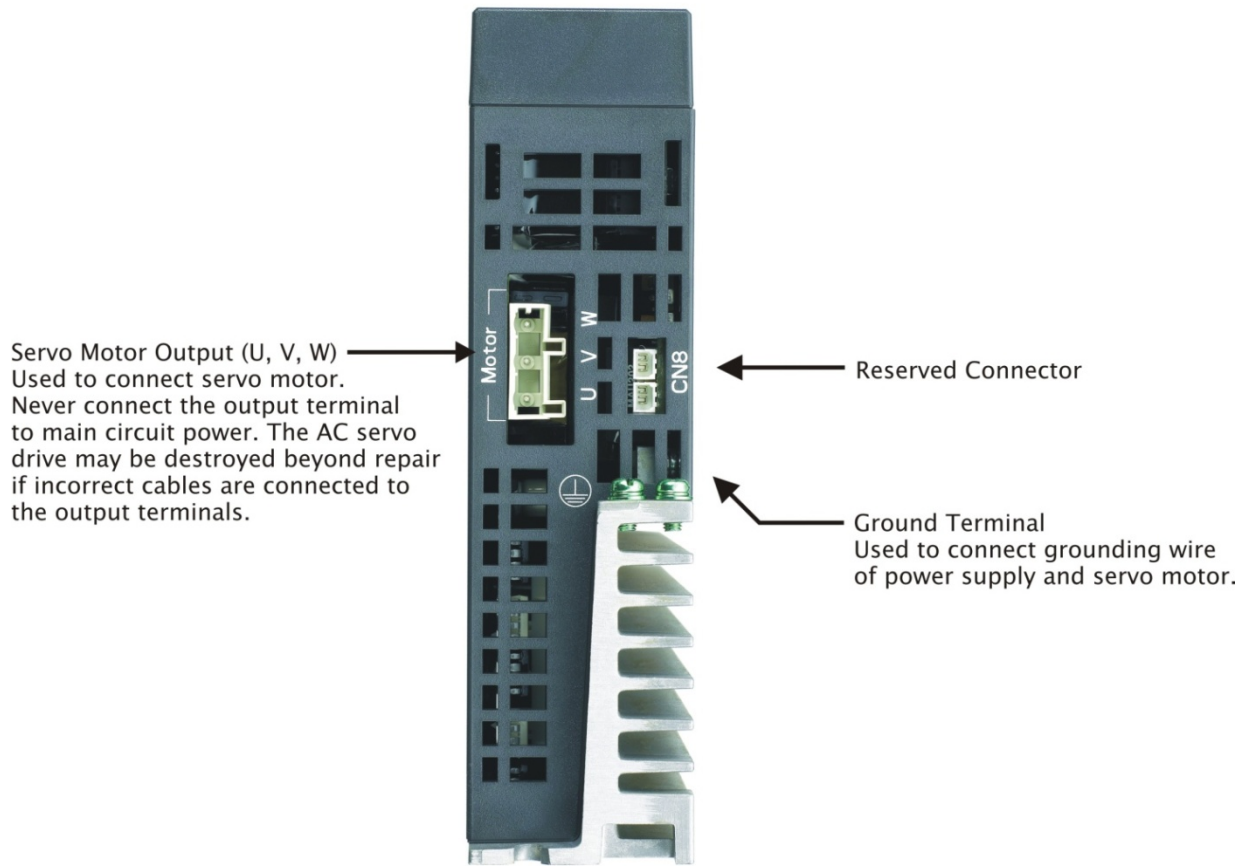

### 1.4.2 400V Series

#### 400V Series - Front View

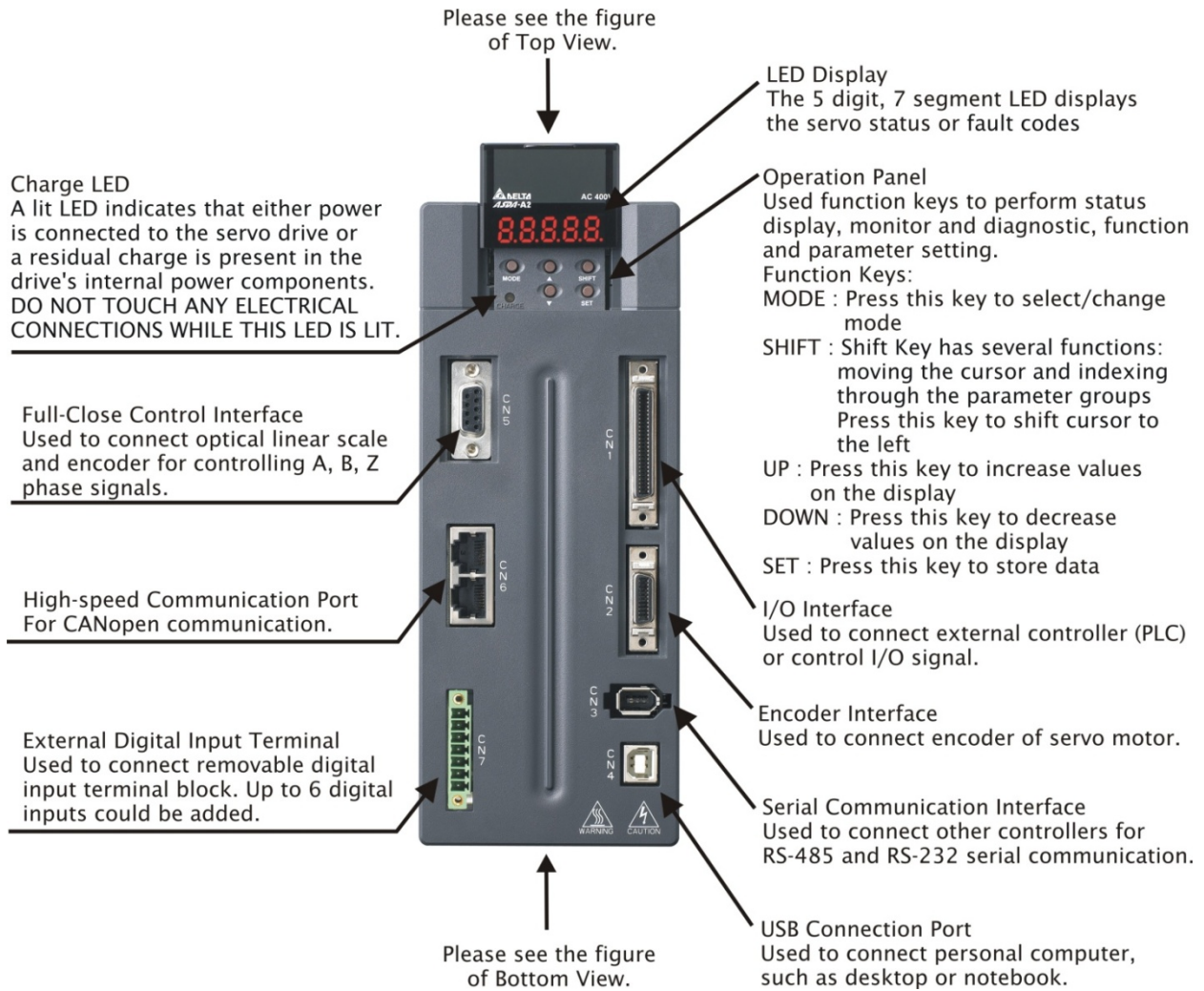

400V Series - Top View

Heatsink  
Used to secure servo drive  
and for heat dissipation.



Internal / External Regenerative Resistor Terminal

- 1) When using an external regenerative resistor, connect P⊕ and C to the regenerative resistor and ensure that the circuit between P⊕ and D is open.
- 2) When using the internal regenerative resistor, ensure that the circuit between P⊕ and D is closed and the circuit between P⊕ and C is open.
- 3) When using the external braking unit, connect the external braking unit to P⊕ and ⊖. Also, ensure that the circuit between P⊕ and D, and P⊕ and C is open.

Control Circuit Terminal (DC24V, DC0V)  
Used to connect 24VDC±10% power supply.

Main Circuit Terminal (R, S, T)  
Used to connect 380~480V, 50/60Hz commercial power supply.

## 400V Series - Bottom View

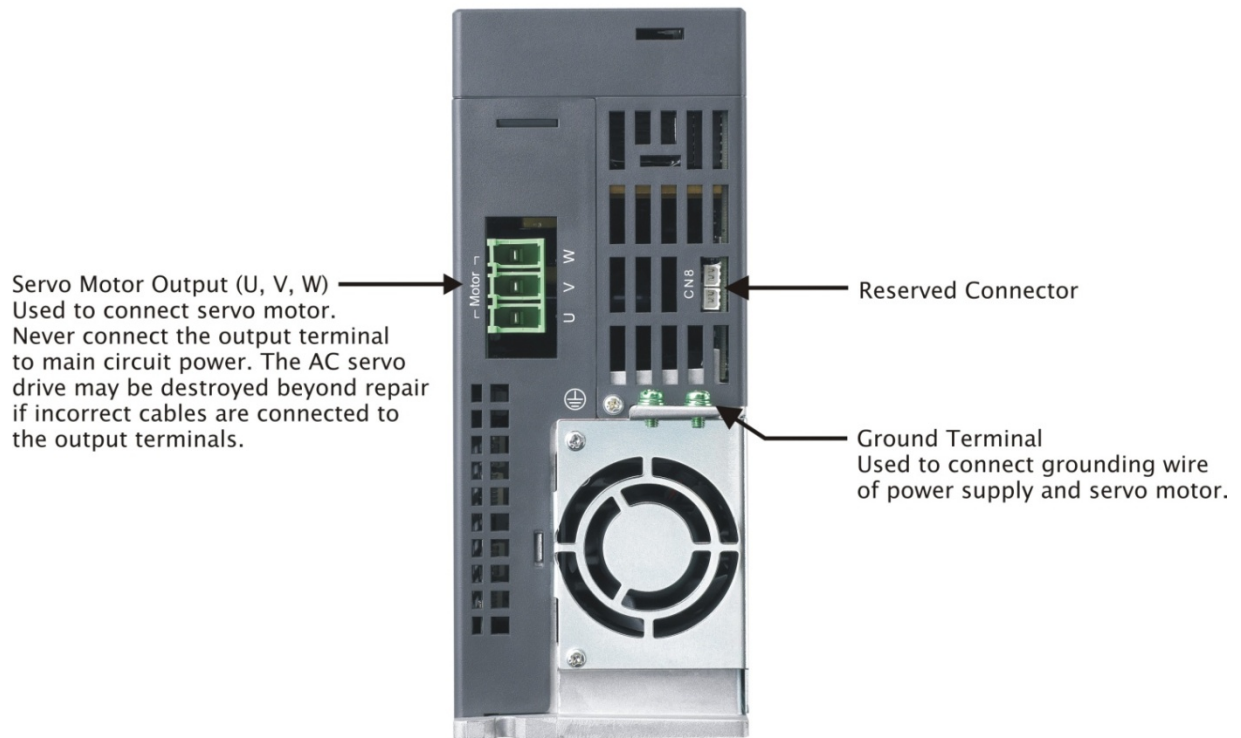

# Chapter 2 Installation

---

## 2.1 Notes

Please pay special attention to the followings:

- If the connection between the servo drive and the servo motor is over 20 meters, please thicken the connecting wire, UVW as well as the encoder cable. Please refer to section 3.1.6 for further information.

## 2.2 Ambient Conditions of Storage

Before the installation, this product has to be kept in shipping carton. In order to retain the warranty coverage and for the maintenance, please follow the instructions below when storage, if the product is not in use temporarily:

- Store the product within an ambient temperature range of -20 °C to +65 °C.
- Store the product within a relative humidity range of 0% to 90% and a non-condensing environment.
- Avoid storing the product in the environment of corrosive gas and liquid.

## 2.3 Ambient Conditions of Installation

The ambient conditions of installing and operating the servo drive:

Location has no over-heat device, no water drop, vapor, dust and oily dust, no corrosive and inflammable gas and liquid, no airborne dust and metal particles, no interference of electromagnetic noise and has solid foundation and no vibration.

The ambient conditions of operating the servo motor:

The ambient temperature is between 0 °C and 40 °C. And the ambient location shall has no over-heat device, no water drop, vapor, dust and oily dust, no corrosive and inflammable gas and liquid, no airborne dust and metal particles.

The best temperature of this servo drive is between 0 °C and 55 °C. If the temperature is over 45 °C, please place the product in a well-ventilated environment so as to ensure its reliability performance. If the product is installed in an electric box, make sure the size of the electric box and its ventilation condition will not overheat and endanger the internal electronic device. Also, pay attention to the vibration of the machine. Check if the vibration will influence the electronic device of the electric box.

## 2.4 Installation Direction and Space

### Notes:

- Incorrect installation may result in a drive malfunction or premature failure of the drive and motor.
- The ASDA-A2 servo drive should be mounted perpendicular to the wall or in the control panel. In order to ensure the drive is well ventilated, ensure that the all ventilation holes are not obstructed and sufficient free space is given to the servo drive. Do not install the drive in a horizontal position or malfunction and damage will occur.
- Do not parallel connect the servo drive, or it might burn out the soft-start resistance or the commutator and danger will occur.

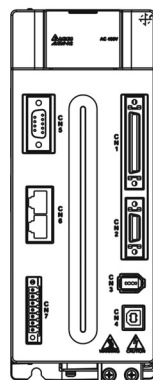

Correct

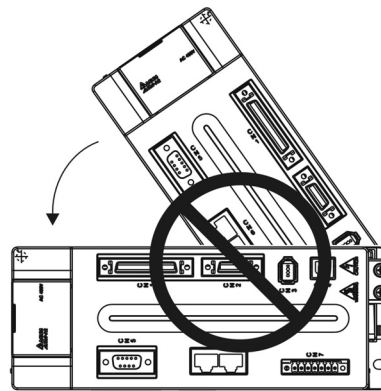

Incorrect

**Scheme of Installation:**

In order to have smaller wind resistance of the fan and increase the ventilation, please follow the suggested clearance value when installing one or more than one servo drives. (Refer to the following diagrams)

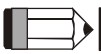
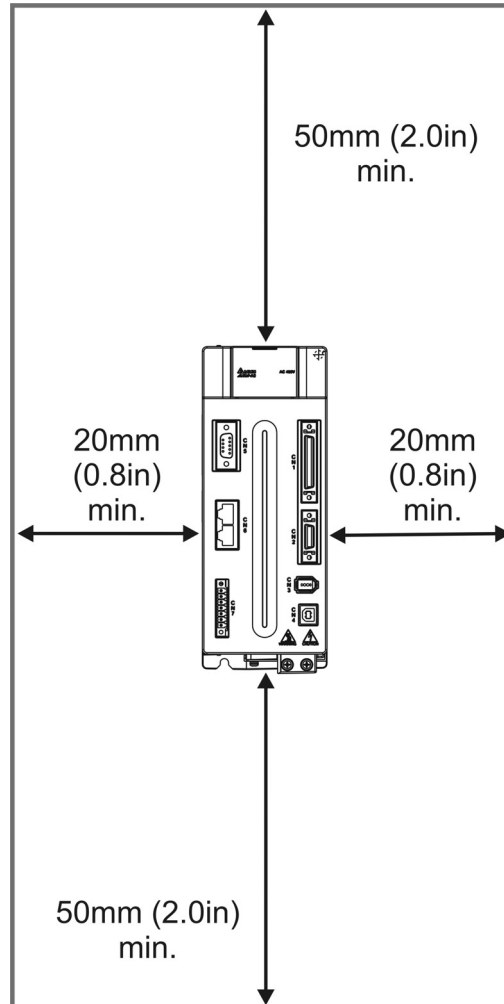
**NOTE**

The above diagrams are not in equal proportion. Please refer to the annotation.



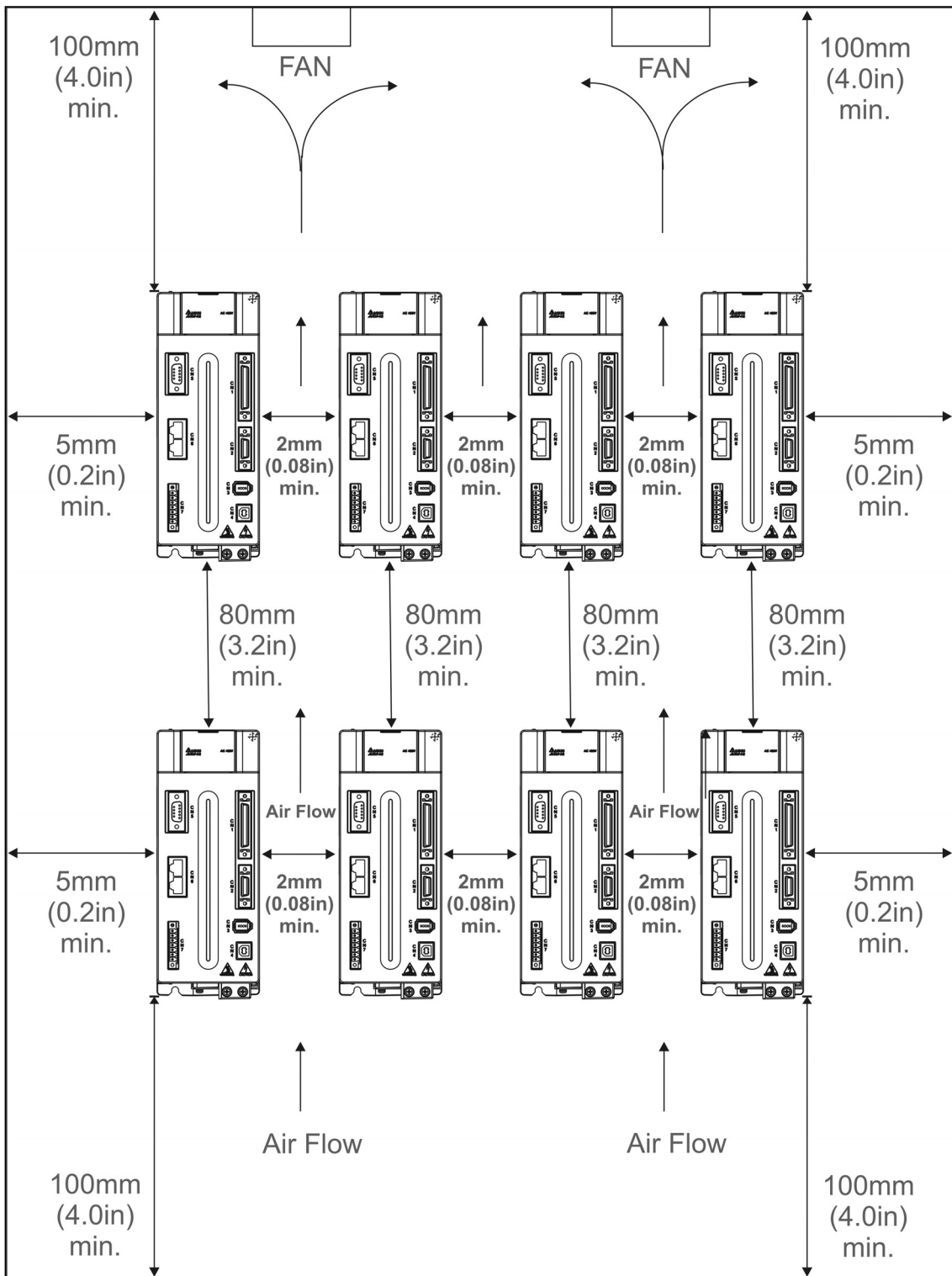

**NOTE**

The above diagrams are not in equal proportion. Please refer to the annotation.

## 2.5 Specification of Circuit Breaker and Fuse

### 220V Series

**Caution: Please use the fuse and circuit breaker that is recognized by UL/CSA.**

Servo Drive Model	Circuit Breaker	Fuse (Class T)
Operation Mode	General	General
ASD-A2-0121-□	5A	5A
ASD-A2-0221-□	5A	5A
ASD-A2-0421-□	10A	10A
ASD-A2-0721-□	10A	20A
ASD-A2-1021-□	15A	25A
ASD-A2-1521-□	20A	40A
ASD-A2-2023-□	30A	50A
ASD-A2-3023-□	30A	70A
ASD-A2-4523-□	70A	140A
ASD-A2-5523-□	75A	150A
ASD-A2-7523-□	95A	175A
ASD-A2-1B23-□	-	-
ASD-A2-1F23-□	-	-



#### NOTE

If the servo drive equips with earth leakage circuit breaker for avoiding electric leakage, please choose the current sensitivity which is over 200 mA and can continue up to 0.1 seconds.

### 400V Series

**Caution: Please use the fuse and circuit breaker that is recognized by UL/CSA.**

Servo Drive Model	Circuit Breaker	Fuse (Class T)
Operation Mode	General	General
ASD-A2-0743-□	10A	20A
ASD-A2-1043-□	15A	25A
ASD-A2-1543-□	20A	40A
ASD-A2-2043-□	30A	50A
ASD-A2-3043-□	30A	70A
ASD-A2-4543-□	70A	140A
ASD-A2-5543-□	75A	150A
ASD-A2-7543-□	95A	175A



#### NOTE

If the servo drive equips with earth leakage circuit breaker for avoiding electric leakage, please choose the current sensitivity which is over 200 mA and can continue up to 0.1 seconds.

## 2.6 EMI Filter Selection

### 220V Series

Item	Power	Servo Drive Model	Recommended EMI Filter		FootPrint
			1PH	3PH	
1	100W	ASD-A2-0121-□	RF007S21AA	RF022B43AA	N
2	200W	ASD-A2-0221-□	RF007S21AA	RF022B43AA	N
3	400W	ASD-A2-0421-□	RF007S21AA	RF022B43AA	N
4	750W	ASD-A2-0721-□	RF007S21AA	RF037B43BA	N
5	1.0kW	ASD-A2-1021-□	RF007S21AA	RF037B43BA	N
6	1.5kW	ASD-A2-1521-□	RF007S21AA	RF037B43BA	N
7	2.0kW	ASD-A2-2023-□	-	RF037B43BA	N
8	3.0kW	ASD-A2-3023-□	-	RF037B43BA	N
9	4.5kW	ASD-A2-4523-□	-	RF075M43BA	N
10	5.5kW	ASD-A2-5523-□	-	RF075M43BA	Y
11	7.5kW	ASD-A2-7523-□	-	30TDRT1W4	Y
12	11.0kW	ASD-A2-1B23-□	-	50TDS4W4C	-
13	15.0kW	ASD-A2-1F23-□	-	50TDS4W4C	-

### 400V Series

Item	Power	Servo Drive Model	Recommended EMI Filter	FootPrint
1	750W	ASD-A2-0743-□	RF007S43AA	N
2	1000W	ASD-A2-1043-□	RF007S43AA	N
3	1500W	ASD-A2-1543-□	RF022B43AA	N
4	2000W	ASD-A2-2043-□	RF037B43BA	N
5	3000W	ASD-A2-3043-□	RF037B43BA	N
6	4500W	ASD-A2-4543-□	RF075M43BA	N
7	5500W	ASD-A2-5543-□	RF075M43BA	Y
8	7500W	ASD-A2-7543-□	RF075M43BA	Y

### EMI Filter Installation

All electronic equipment (including servo drive) generates high or low frequency noise during operation and interfere the peripheral equipments via conduction or radiation. With EMI Filter and the correct installation, much interference can be eliminated. It is suggested to use Delta's EMI Filter to suppress the interference better.

When installing servo drive and EMI Filter, please follow the instructions of the user manual and make sure it meets the following specification:

1. EN61000-6-4 (2001)
2. EN61800-3 (2004) PDS of category C2
3. EN55011+A2 (2007) Class A Group 1

### General Precaution

In order to ensure the best performance of EMI Filter, apart from the instructions of servo drive installation and wiring, please follow the precautions mention below:

1. The servo drive and EMI Filter should be installed on the same metal plate.
2. When installing servo drive and EMI Filter, the servo drive should be installed above the EMI Filter.
3. The wiring should be as short as possible.
4. The metal plate should be well grounded.
5. The metal cover of the servo drive and EMI Filter or grounding should be firmly fixed on the metal plate. Also, the contact area should be as large as possible.

### Motor Cable Selection and Installation Precautions

The selection of motor cables and installation affect the performance of EMI Filter. Please follow the precautions mention below.

1. Use the cable that has braid shielding (The effect of double shielding is better)
2. The shield on both sides of the motor cable should be grounded in the shortest distance and the largest contact area.
3. The protective paint of the U-shape saddle and metal plate should be removed in order to ensure the good contact. Please see figure 1.
4. It should have correct connection between the braid shielding of the motor cable and the metal plate. The braid shielding on both sides of the motor cable should be fixed by the U-shape saddle and metal plate. Please see figure 2 for the correct connection.

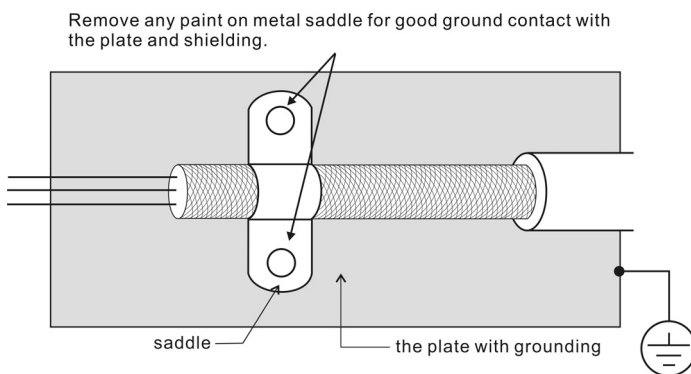

Figure 1

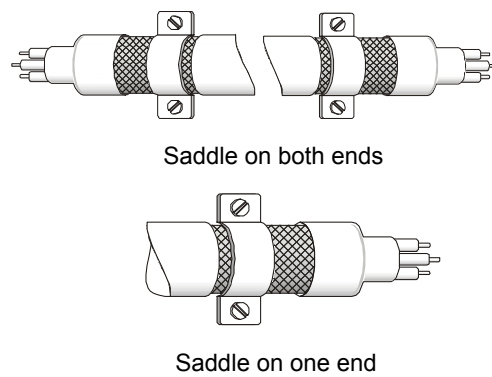

Figure 2

## 2.7 Selection of Regenerative Resistor

When the direction of pull-out torque is different from the rotation, it means the electricity is sent back to the servo drive from the load-end. It becomes the capacitance of DC Bus and increases the voltage. When the voltage increases to a specific value, the come-back electricity can only be consumed by regenerative resistor. There is a built-in regenerative resistor in the servo drive. Users can also use the external regenerative resistor if needed.

### Specification of built-in regenerative resistor provided by ASDA-A2 220V Series

Servo Drive (kW)	Specification of built-in regenerative resistor		*1The capacity of built-in regenerative resistor (Watt)	Minimum allowable resistance (Ohm)
	Resistance (P1-52) (Ohm)	Capacity (P1-53) (Watt)		
0.1	-	-	-	30
0.2	-	-	-	30
0.4	40	40	20	30
0.75	40	60	30	20
1.0	40	60	30	20
1.5	40	60	30	20
2.0	20	100	50	10
3.0	20	100	50	10
4.5	20	100	50	10
5.5	-	-	-	8
7.5	-	-	-	5
11	-	-	-	8
15	-	-	-	5

### Specification of built-in regenerative resistor provided by ASDA-A2 400V Series

Servo Drive (kW)	Specification of built-in regenerative resistor		Minimum allowable resistance (Ohm)
	Resistance (P1-52) (Ohm)	Capacity (P1-53) (Watt)	
0.75	80	100	60
1.0	80	100	60
1.5	80	100	40
2.0	-	-	40
3.0	-	-	30
4.5	-	-	20
5.5	-	-	20
7.5	-	-	15

When the regenerative resistor exceeds the capacity of built-in regenerative resistor, the external regenerative resistor should be applied. Please pay special attention to the followings when using the regenerative resistor.

1. Please correctly set up the resistance (P1-52) and capacity (P1-53) of regenerative resistor. Or it might influence the performance of this function.
2. If users desire to use the external regenerative resistor, please make sure the applied value should not smaller than the built-in regenerative resistor. In general application, more than one resistor will be serial connected. If the value (from serial connected resistors) exceeds the setting range, users can reduce the value by parallel connecting the resistor. If users desire to connect it in parallel to increase the power of regenerative resistor, please make sure the capacitance meets the requirements.

Please refer to the followings for the calculation when serial / parallel connecting regenerative resistors:

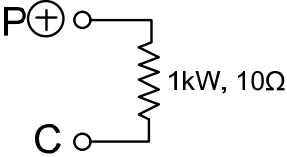
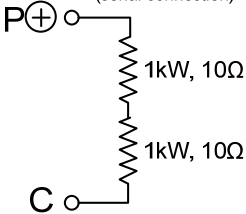
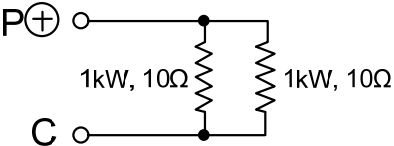
<p>External Regenerative Resistor</p> 	<p>Setting: P1-52=10 (<math>\Omega</math>) P1-53=1000 (W)</p>
<p>External Regenerative Resistor (serial connection)</p> 	<p>Setting: P1-52=20 (<math>\Omega</math>) P1-53=2000 (W)</p>
<p>External Regenerative Resistor (parallel connection)</p> 	<p>Setting: P1-52=5 (<math>\Omega</math>) P1-53=2000 (W)</p>

3. In natural environment, if the capacity of regenerative resistor (the average value) is within the rated capacity, the temperature of the capacitance will increase to 120°C or even higher (under the condition of regenerative energy keeps existing). For safety concerns, please apply the method of forced cooling in order to reduce the temperature of regenerative resistor. Or, it is suggested to use the regenerative resistor which is equipped with thermal switches. Please contact the distributors for load characteristics of the regenerative resistor.

When using the external regenerative resistor, the resistor should connect to P, C terminal and the contact of P, D terminal should be opened. It is recommended to choose the above mentioned capacitance. For easy calculation of regenerative resistor capacity, except the energy consumed by IGBT, two ways are provided to select the capacity of external regenerative resistor according to the selected linear motor or rotary motor.

## (1) Regenerative Power Selection

(a) When the external load on torque does not exist

If the motor operates back and forth, the energy generated by the brake will go into the capacitance of DC bus. When the voltage of the capacitance exceeds a specific value, the redundant energy will be consumed by regenerative resistor. Two ways of selecting regenerative resistor are provided here. The table below provides the energy calculation method. Users can refer to it and calculate the selected regenerative resistor.

**220V**

Servo Drive (kW)	Motor	Rotor Inertia J ( $\times 10^{-4}$ kg.m <sup>2</sup> )	Regenerative power from empty load 3000r/min to stop Eo (joule)	The maximum regenerative power of capacitance Ec (joule)
Low Inertia	0.1 ECMA-C $\Delta$ 040F□□	0.021	0.10	4.21
	0.1 ECMA-C $\Delta$ 0401□□	0.037	0.18	4.21
	0.2 ECMA-C $\Delta$ 0602□□	0.177	0.87	5.62
	0.4 ECMA-C $\Delta$ 0604□□	0.277	1.37	8.42
	0.4 ECMA-C $\Delta$ 0804□□	0.68	3.36	8.42
	0.75 ECMA-C $\Delta$ 0807□□	1.13	5.59	17.47
	1.0 ECMA-C $\Delta$ 1010□□	2.65	13.10	21.22
	1.0 ECMC-C $\Delta$ 0910□□	2.62	12.96	21.22
	2.0 ECMA-C $\Delta$ 1020□□	4.45	22.0	25.58
	3.0 ECMA-C $\Delta$ 1330□□	12.7	62.80	25.58
Medium Inertia	0.4 ECMA-E $\Delta$ 1305□□	8.17	40.40	8.42
	1.0 ECMA-E $\Delta$ 1310□□	8.41	41.59	21.22
	1.5 ECMA-E $\Delta$ 1315□□	11.18	55.29	25.58
	2.0 ECMA-E $\Delta$ 1320□□	14.59	72.15	25.58
	2.0 ECMA-E $\Delta$ 1820□□	34.68	171.49	25.58
	3.0 ECMA-E $\Delta$ 1830□□	54.95	271.73	31.20
	3.0 ECMA-E $\Delta$ 1835□□	54.95	271.73	31.20
Medium -High Inertia	1.0 ECMA-F $\Delta$ 1308□□	13.6	67.25	21.22
	2.0 ECMA-F $\Delta$ 1313□□	20.0	98.90	25.58
	2.0 ECMA-F $\Delta$ 1318□□	24.9	123.13	31.20
	3.0 ECMA-F $\Delta$ 1830□□	54.95	271.73	28
	4.5 ECMA-F $\Delta$ 1845□□	77.75	384.48	25
	5.5 ECMA-F $\Delta$ 1855□□	99.78	493.42	27
	7.5 ECMA-F $\Delta$ 1875□□	142.7	705.66	93



Servo Drive (kW)		Motor	Rotor Inertia J ( $\times 10^{-4}$ kg.m <sup>2</sup> )	Regenerative power from empty load 3000r/min to stop Eo (joule)	The maximum regenerative power of capacitance Ec (joule)
Medium -High Inertia	11.0	ECMA- F $\Delta$ 221B□□	329.0	723.08	117
	15.0	ECMA- F $\Delta$ 221F□□	553.0	1215.38	156
High Inertia	0.4	ECMA-G $\Delta$ 1303□□	8.17	17.96	8.42
	0.75	ECMA-F $\Delta$ 1305□□	10.3	22.64	17.47
	0.75	ECMA-G $\Delta$ 1306□□	8.41	18.48	17.47
	1.0	ECMA-G $\Delta$ 1309□□	11.18	24.57	21.22

$E_o = J * \omega r^2 / 182$  (joule),  $W_r$ : r/min

#### 400V

Servo Drive (kW)		Motor	Rotor Inertia J ( $\times 10^{-4}$ kg.m <sup>2</sup> )	Regenerative power from empty load 3000r/min to stop Eo (joule)	The maximum regenerative power of capacitance Ec (joule)
Low Inertia	0.75	ECMA-J $\Delta$ 0604□□	0.277	1.37	42.43
	0.75	ECMA-J $\Delta$ 0807□□	1.13	5.59	42.43
	0.75	ECMA-J $\Delta$ 0907□□	1.93	9.54	42.46
	1.0	ECMA-J $\Delta$ 1010□□	2.65	13.10	42.43
	1.5	ECMA-J $\Delta$ 1010□□	2.65	13.10	42.43
	2.0	ECMA-J $\Delta$ 1020□□	4.45	22.01	42.43
Medium Inertia	0.75	ECMA-K $\Delta$ 1305□□	8.17	40.40	51.17
	1.0	ECMA-K $\Delta$ 1310□□	8.41	41.59	51.17
	1.5	ECMA-K $\Delta$ 1315□□	11.18	55.29	57.41
	2.0	ECMA-K $\Delta$ 1320□□	14.59	72.15	34.94
	2.0	ECMA-K $\Delta$ 1820□□	34.68	171.49	34.94

Servo Drive (kW)	Motor	Rotor Inertia J ( $\times 10^{-4}$ kg.m <sup>2</sup> )	Regenerative power from empty load 3000r/min to stop Eo (joule)	The maximum regenerative power of capacitance Ec (joule)	
Medium –High Inertia	0.75	ECMA-L△1305□□	13.1	16.20	42.43
	1.5	ECMA-L△1313□□	23.6	29.18	42.43
	3.0	ECMA-L△1830□□	54.95	67.93	42.43
	3.0	ECMA-J△1330□□	12.7	15.70	42.43
	4.5	ECMA-L△1845□□	77.75	96.12	51.17
	5.5	ECMA-L△1855□□	99.78	123.35	57.41
	7.5	ECMA-L△1875□□	142.7	176.41	62.40
High Inertia	1.0	ECMA-L△1308□□	17.1	84.56	42.43
	1.5	ECMA-M△1309□□	11.18	55.29	57.41

$E_o = J * \omega^2 / 182$  (joule),  $\omega$ : r/min

Assume that the load inertia is N times to the motor inertia and the motor decelerates from 3000r/min to 0, its regenerative energy is  $(N+1) \times E_o$ . The consumed regenerative resistor is  $(N+1) \times E_o - E_c$  joule. If the cycle of back and forth operation is T sec, then the power of regenerative resistor it needs is  $2 \times ((N+1) \times E_o - E_c) / T$ .

Followings are the calculation procedure:

Steps	Item	Calculation and Setting Method
1	Set the capacity of regenerative resistor to the maximum	Set P1-53 to the maximum value
2	Set T cycle of back and forth operation	Enter by the user
3	Set the rotational speed $\omega$	Enter by the user or read via P0-02
4	Set the load/motor inertia ratio N	Enter by the user or read via P0-02
5	Calculate the maximum regenerative energy $E_o$	$E_o = J * \omega^2 / 182$
6	Set the absorbable regenerative energy $E_c$	Refer to the above table
7	Calculate the needful capacitance of regenerative resistor	$2 \times ((N+1) \times E_o - E_c) / T$

Take 400W as the example, the cycle of back and forth operation is  $T = 0.4\text{sec}$ , the maximum speed is 3000r/min and the load inertia is 7 times to the motor inertia. Then, the needful power of regenerative resistor is  $2 \times ((7+1) \times 1.68 - 8) / 0.4 = 27.2\text{ W}$ . If it is smaller than the built-in capacity of regenerative resistor, the built-in 60W regenerative resistor will do. Generally speaking, when the need of the external load inertia is not much, the built-in regenerative is enough. The diagram below describes the actual operation. The smaller power of the regenerative resistor it is, the more energy it accumulates and the higher temperature it will be. When the temperature is higher than a specific value, ALE05 occurs.

(b) If the external load torque exists, the motor is in reverse rotation.

Usually, the motor is in forward rotation, which means the torque output direction of the motor is the same as the rotation direction. However, in some applications, the direction of torque output is different from the rotation. In this situation, the motor is in reverse rotation. The external energy goes into the servo drive through the motor. The diagram below is one example. When the external force direction is the same as the moving direction, the servo system has to use the force of the opposite direction to keep the speed and stability. Huge amount of energy will return to the servo drive at the moment. When DC-BUS is full and unable to store the regenerative energy, the energy will be led to regenerative resistor and consumed.

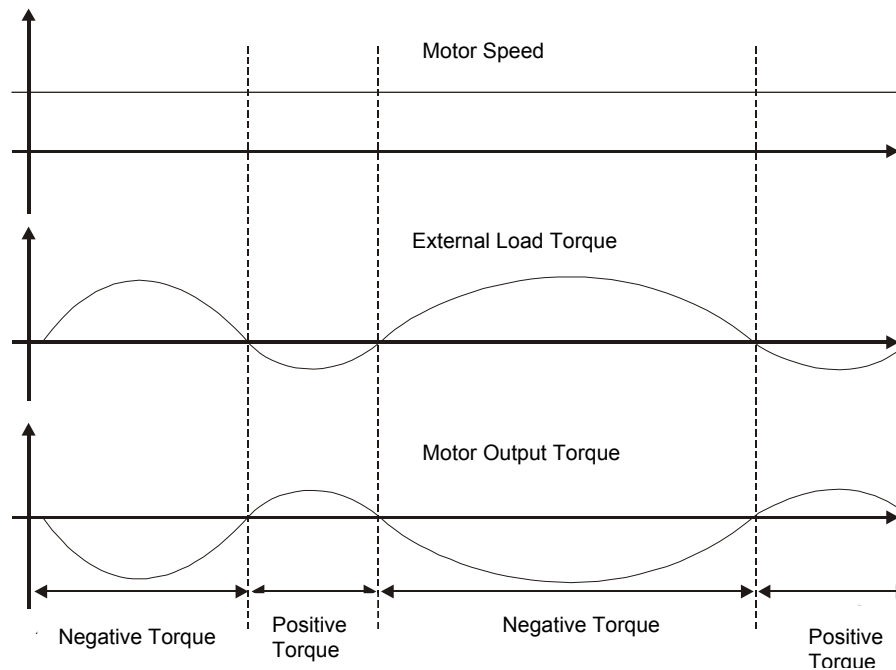

Negative torque:  $T_L \times W_r$      $T_L$ : external load torque

For safety reasons, please calculate it by considering the safest situation.

For example, when the external load torque is the +70% rated torque and the rotation reaches 3000 r/min, then take 400 W (the rated torque is 1.27 Nt-m) as the example, the user has to connect the regenerative resistor of  $40\Omega$ , which is  $2 \times (0.7 \times 1.27) \times (3000 \times 2 \times \pi / 60) = 560\text{W}$ .

## (2) Simple Selection

Choose the appropriate regenerative resistor according to the allowable frequency and empty load frequency in actual operation. The so-called empty allowable frequency is the frequency of continuous operation when the servo motor runs from 0r/min to the rated speed and then decelerates from the rated speed to 0r/min within the shortest time. The following table lists the allowable frequency when the servo drive runs without load (times/min).

Allowable frequency when the servo motor runs without load (times/min) and uses a built-in regenerative resistor													
Motor Capacity	600W	750W	900W	1.0 kW	1.5 kW	2.0 kW	2.0 kW	3.0 kW	4.5 kW	5.5 kW	7.5 kW	11.0 kW	15.0 kW
Servo Motor	06	07	09	10	15	20	20	30	45	55	75	1B	1F
ECMA□□C	-	312	-	137	-	83 (F100)	-	-	-	-	-	-	-
ECMA□□E	-	-	-	42	32	24 (F130)	10 (F180)	11	-	-	-	-	-
ECMA□□F	-	-	-	-	-	-	-	11	8	-	-	-	-
ECMA□□G	42	-	31	-	-	-	-	-	-	-	-	-	-
ECMA□□J	-	537	-	-	-	-	-	-	-	-	-	-	-
ECMA□□K	-	-	-	162	122	-	-	-	-	-	-	-	-
ECMA□□L	-	-	-	-	-	-	-	-	-	-	-	-	-

When the servo motor runs with load, the allowable frequency will be different according to different load inertia or speed. The following is the calculation method.

m represents load / motor inertia ratio.

$$\text{Allowable frequency} = \frac{\text{Allowable frequency when servo motor run without load}}{m + 1} \times \left( \frac{\text{Rated speed}}{\text{Operating speed}} \right)^2 \frac{\text{times}}{\text{min.}}$$

The comparison table of external regenerative resistor is provided below. Please choose the appropriate regenerative resistor according to the allowable frequency.

The table below describes the suggested allowable frequency (times/min) of regenerative resistor when the servo drive runs without load.

Allowable frequency of regenerative resistor when the servo drive runs without load (times/min)								
Corresponding Motor	Motor Capacity	ECMA□□C						
		100W	200W	400W (F60)	400W (F80)	750W	1.0kW	2.0kW
		01	02	04	04	07	10	20
BR400W040 (400W 40Ω)	-	-	8608	3506	2110	925	562	
BR1K0W020 (1kW 20Ω)	-	-	-	8765	5274	2312	1406	

Motor Capacity	ECMA□□E					
	0.5kW	1kW	1.5kW	2.0kW (F130)	2.0kW (F180)	3.0kW
Corresponding Motor	05	1.0	15	20	20	30
BR400W040 (400W 40Ω)	291	283	213	163	68	-
BR1K0W020 (1kW 20Ω)	729	708	533	408	171	-
BR1K5W005*2 (3kW 10Ω)	-	-	-	-	-	331

Motor Capacity	ECMA□□F					
	3.0KW	4.5KW	5.5KW	7.5kW	11.0kW	15.0kW
Corresponding Motor	30	45	55	75	1B	1F
BR1K5W005*2 (3kW 10Ω)	331	234	182	127	124	74

Allowable frequency of regenerative resistor when the servo drive runs without load (times/min)			
Motor Capacity	ECMA□□G		
	0.3kW	0.6kW	0.9kW
Corresponding Motor	03	06	09
BR400W040 (400W 40Ω)	292	283	213
BR1K0W020 (1kW 20Ω)	729	708	533

Motor Capacity	ECMA□□K		
	1.0kW	1.5kW	2.0kW
Corresponding Motor	10	15	20
BR400W040 (400W 40Ω)	-	488	665

Motor Capacity	ECMA□□L			
	3.0KW	4.5KW	5.5KW	7.5kW
Corresponding Motor	30	45	55	75
BR400W040 (400W 40Ω)	177	-	-	-
BR1K0W020 (1kW 20Ω)	-	312	243	170

If watt is not enough when using regenerative resistor, connecting the same regenerative resistor in parallel can increase the power.

### Dimensions of Regenerative Resistor

Delta Part Number : BR400W040 (400W 40Ω)

L1	L2	H	D	W	MAX. WEIGHT (g)
265	250	30	5.3	60	930

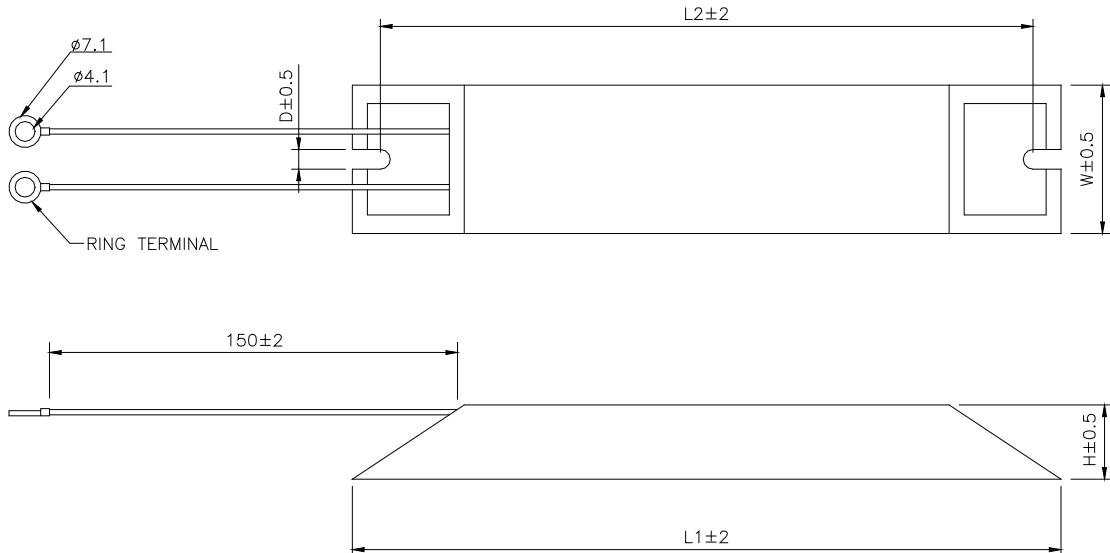

Delta Part Number : BR1K0W020 (1kW 20Ω)

L1	L2	H	D	W	MAX. WEIGHT (g)
400	385	50	5.3	100	2800

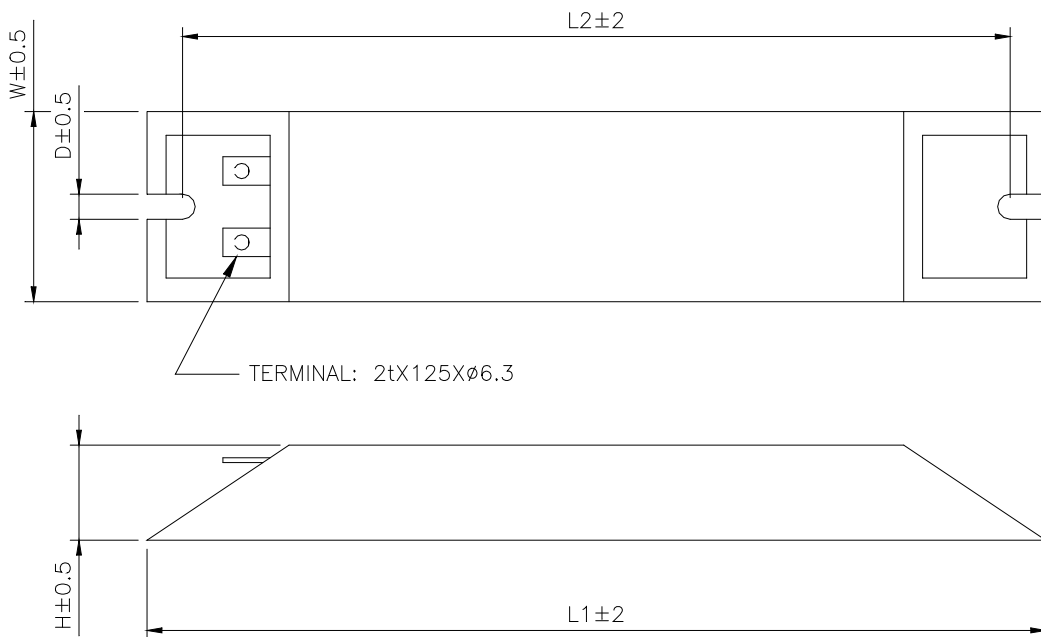

Delta Part Number : BR1K5W005 (3kW 10Ω)

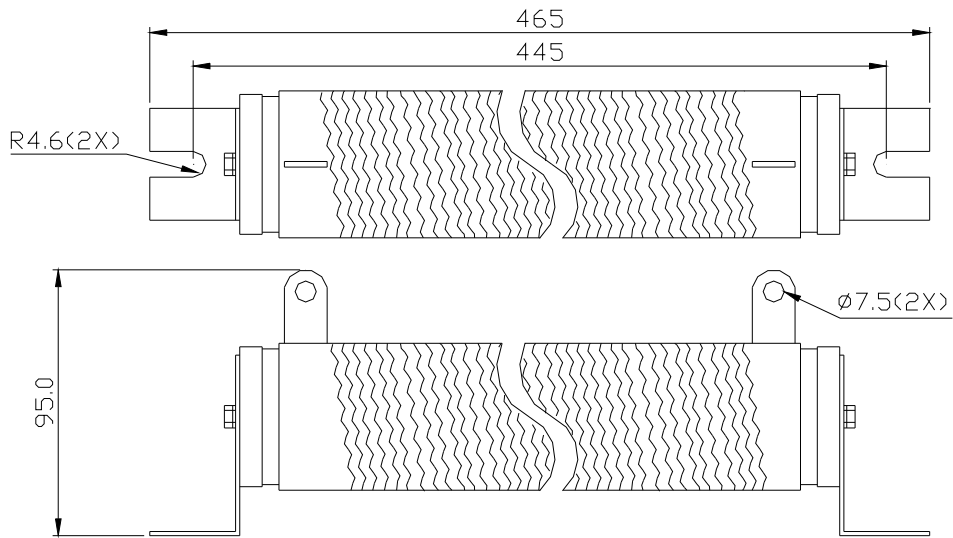

# Chapter 3 Wiring

This chapter provides information on wiring ASDA-A2 series products, the descriptions of I/O signals and gives typical examples of wiring diagrams.

## 3.1 Connections - 220V series

### 3.1.1 Connecting to Peripheral Devices

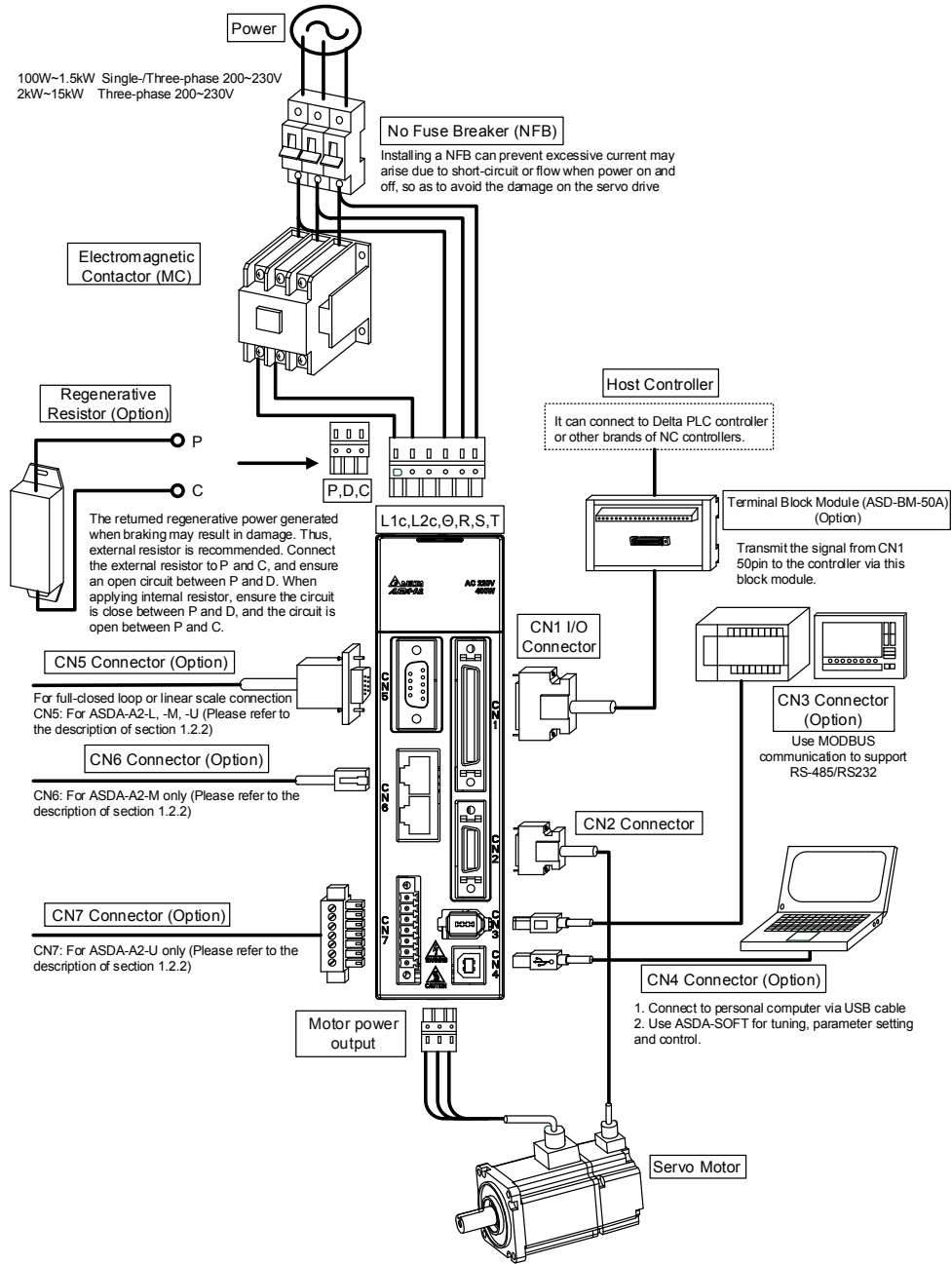



**NOTE**

Installation notes:

1. Check if the power and wiring among R, S, T and L1c, L2c are correct.  
Please refer to Chapter 11 for Specifications. Make sure the input voltage is correct, or it might damage the servo drive or danger may occur.
2. Please check if the output terminal U, V, W of the servo motor is correctly wired. The incorrect wiring may disable the operation of the motor or cause malfunction.
3. When applying to the external regenerative resistor, the contact between P<sup>+</sup> and D should be opened and the external regenerative resistor should connect to terminal P<sup>+</sup> and C. When applying to the internal regenerative resistor, the contact between P<sup>+</sup> and D should be closed and the contact between P<sup>+</sup> and C should be opened.
4. When an alarm occurs or the system is in emergency stop status, use ALARM or WARN to output and disconnect the power of magnetic contactor in order to disconnect the power of servo drive.

### 3.1.2 Connectors and Terminals of Servo Drive

Terminal Signal	Name	Description		
<b>L1c, L2c</b>	Power input of the control circuit	Connect to single-phase AC power (select the appropriate voltage specification according to the product )		
<b>R, S, T</b>	Power input of the main circuit	Connect to three-phase AC power (select the appropriate voltage specification according to the product)		
<b>U, V, W FG</b>	Motor cable	Connect to the servo motor		
		Terminal Symbol	Wire Color	Description
		U	Red	Three-phase main power cable of the motor.
		V	White	
		W	Black	
FG	Green	Connect to ground terminal ( $\ominus$ ) of the servo drive.		
<b>P<sup>+</sup>, D, C, <math>\ominus</math></b>	Regenerative resistor terminal or braking unit	Internal resistor	The contact between P <sup>+</sup> and D end should be closed; contact between P <sup>+</sup> and C end should be opened.	
		External resistor	Connect P <sup>+</sup> , C ends to the resistor and the contact between P <sup>+</sup> and D end should be opened.	
		External braking unit	P <sup>+</sup> and P <sup>-</sup> of the brake unit should connect to P <sup>+</sup> and P <sup>-</sup> respectively. The contact between P <sup>+</sup> and D and P <sup>+</sup> and C should be opened.	

	Ground terminal	Connect to the ground wire of power and servo motor.
<b>CN1</b>	I/O connector (Option)	Connect to the host controller. Please refer to section 3.4.
<b>CN2</b>	Connector (Option)	Connect encoder of the motor. Please refer to section 3.5.
<b>CN3</b>	Connector (Option)	Connect to RS-485 or RS-232. Please refer to section 3.6.
<b>CN4</b>	USB connector (Type B) (Option)	Connect to personal computer (PC or notebook). Please refer to section 3.7.
<b>CN5</b>	Connector (Option)	Connect to linear scale or encoder for full-closed loop and motor feedback. Please refer to section 3.8.
<b>CN6</b>	CANopen connector (Option)	RJ45 connector. Please refer to section 3.9.
<b>CN7</b>	Extension digital input connector (Option)	Extension DI connector. Please refer to section 3.10.
<b>CN8</b>	Battery connector	Connector for absolute type of battery box

Pay special attention to the followings when wiring:

1. When the power is cutoff, do not touch R, S, T and U, V, W since the capacitance inside the servo drive still contains huge amount of electric charge. Wait until the charging light is off.
2. Separate R, S, T and U, V, W from the other wires. The interval should be at least 30 cm (11.8 inches).
3. If the wire of encoder CN2 or CN5 connector is not long enough, please use shielded twisted-pair cable which cannot exceed 20 meters (65.62 inches). If it exceeds 20 meters, please choose the bigger wire diameter of signal cable to ensure it will not cause signal fading. As for the encoder wiring specification of 20-meter-long cable, please use AWG26 of wire size and metal braided shield twisted-pair cable which complies with the standard of UL 2464.
4. When using CANopen, please use the standard shielded twisted-pair cables to ensure the communication quality.
5. When selecting the wire rod, please refer to Section 3.1.6.
6. Do not install the plug-in capacitance in servo drive. It might burn out the soft-start resistance and danger will occur.

### 3.1.3 Wiring Method

The wiring method of 220V servo drive is divided into single-phase and three-phase. In the diagram below, Power On is contact **a**, Power Off and ALRM\_RY are contact **b**. MC is the coil of magnetic contactor and self-remaining power and is the contact of main power circuit.

- Wiring Method of Single-phase Power Supply (suitable for 1.5 kW and models below 1.5 kW)

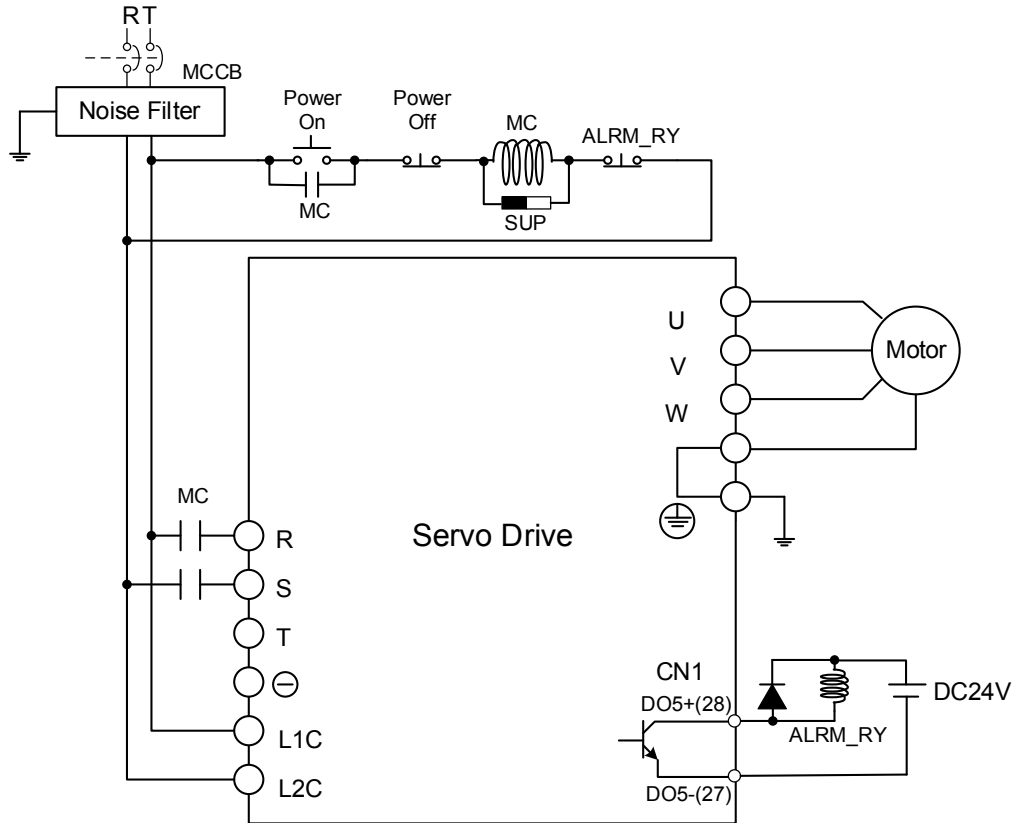

■ Wiring Method of Three-phase Power Supply (suitable for all series)

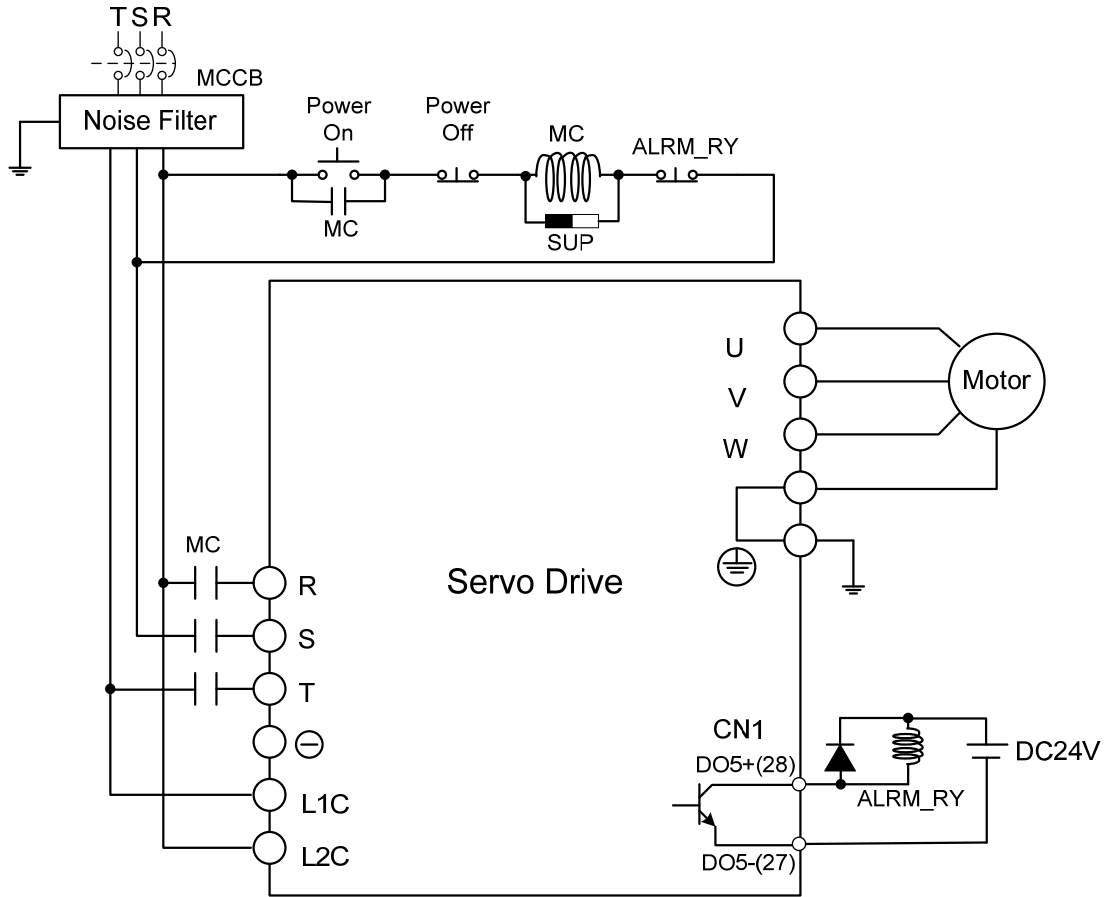

### 3.1.4 Specification of Motor Power Cable

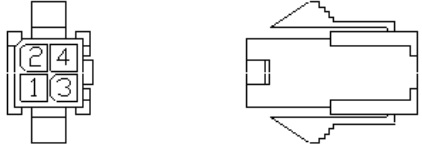
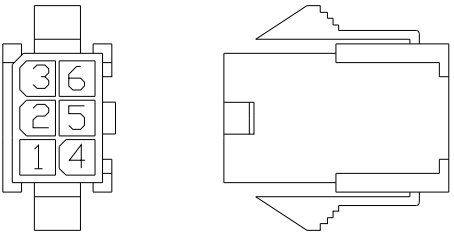
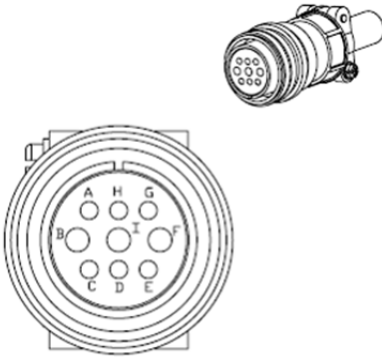
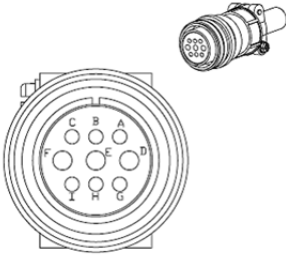
Motor Model	U, V, W / Connector of Brake	Terminal Definition
ECMA-C1040F□S (50W) ECMA-C△0401□S (100W) ECMA-C△0602□S (200W) ECMA-C△0604□S (400W) ECMA-C△0604□H (400W) ECMA-C△0804□7 (400W) ECMA-C△0807□S (750W) ECMA-C△0807□H (750W) ECMA-C△0907□S (750W) ECMA-C△0910□S (1000W)		A
ECMA-C1040F□S (50W) ECMA-C△0401□S (100W) ECMA-C△0602□S (200W) ECMA-C△0604□S (400W) ECMA-C△0804□7 (400W) ECMA-C△0807□S (750W) ECMA-C△0907□S (750W) ECMA-C△0910□S (1000W) *□ : with brake		B
ECMA-G△1303□S (300W) ECMA-E△1305□S (500W) ECMA-F△1305□S (500W) ECMA-G△1306□S (600W) ECMA-F△1308□S (850W) ECMA-G△1309□S (900W) ECMA-C△1010□S (1000W) ECMA-E△1310□S (1000W) ECMA-F△1313□S (1300W) ECMA-E△1315□S (1500W) ECMA-F△1318□S (1800W) ECMA-C△1020□S (2000W) ECMA-E△1320□S (2000W) ECMA-C△1330□4 (3000W)	 3106A-20-18S	C
ECMA-E△1820□S (2000W) ECMA-E△1830□S (3000W) ECMA-F△1830□S (3000W) ECMA-E△1835□S (3500W) ECMA-F△1845□S (4500W)	 3106A-24-11S	D

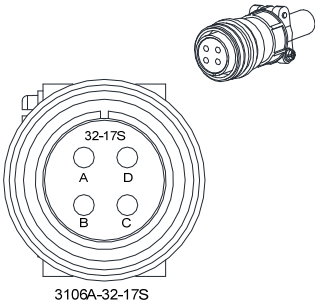
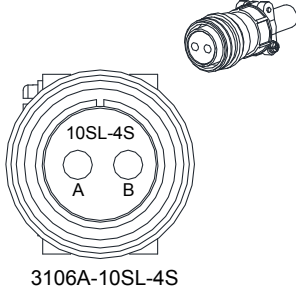
Motor Model	U, V, W / Connector of Brake	Terminal Definition
ECMA-F△1855□3 (5500W) ECMA-F△1875□3 (7500W) ECMA-F1221B□3 (11kW) ECMA-F1221F□S (15kW)	 <p>3106A-32-17S</p>	E
ECMA-F21855□3(5500W) ECMA-F21875□3(7500W)	 <p>3106A-10SL-4S</p>	F

Wiring Name	U (Red)	V (White)	W (Black)	CASE GROUND (Green)	BRAKE1 (Yellow)	BRAKE2 (Blue)
A	1	2	3	4	-	-
B	1	2	4	5	3	6
C	F	I	B	E	G	H
D	D	E	F	G	A	B
E	A	B	C	D	-	-

Wiring Name	BRAKE1	BRAKE2
F	A	B

When selecting the wire rod, please choose 600V PVC cable and the length should not longer than 30m. If the length exceeds 30m, please take the received voltage into consideration when selecting the wire size. Please refer to Section 3.1.6 for wire rod selection.

 **NOTE**

- 1) No polarity for brake coil, the wiring name is BRAKE1 & BRAKE2.
- 2) Power for brake is DC24 V. Never share it with the power of control signal VDD.
- 3) Box, (△) in servo motor model represents encoder type. △= 1: incremental, 20-bit; △= 2: incremental, 17-bit; △= 3: 33-bit; △= A: absolute.
- 4) Box, (□) in servo motor model represents brake or keyway / oil seal.

### 3.1.5 Specification of Encoder Cable Connector

Encoder Connection (Diagram 1)

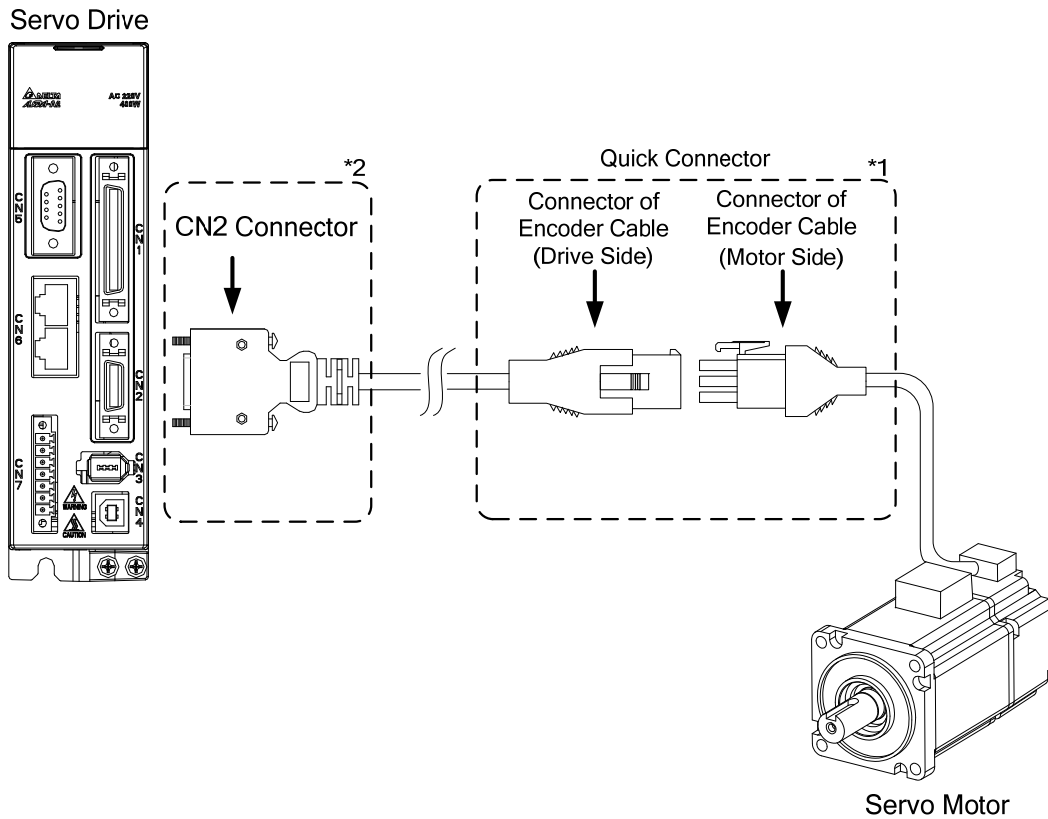

**NOTE**

This diagram shows the connection between the servo drive and the motor encoder. It is not drawn by the practical scale and specification will be different according to the selected servo drive and motor model.

- 1) Please refer to the Section of Specification and Definition of Encoder Connector.
- 2) Please refer to Section 3.5 CN2 Connector.

Motor Model	Connector of Encoder Cable
ECMA-C1040F□ (50W) ECMA-C△0401□S (100W) ECMA-C△0602□S (200W) ECMA-C△0604□S (400W) ECMA-C△0604□H (400W) ECMA-C△0804□7 (400W) ECMA-C△0807□S (750W) ECMA-C△0807□H (750W) ECMA-C△0907□S (750W) ECMA-C△0910□S (1000W)	

Specification and Definition of Encoder Connector:

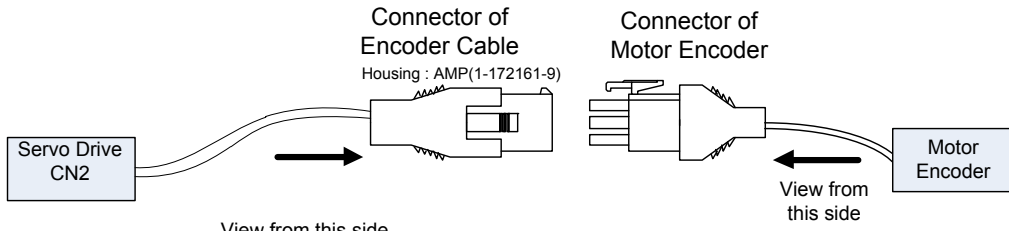

View from this side

<b>1</b> Blue T+	<b>2</b> Reserved	<b>3</b> Reserved
<b>4</b> Blue/Black T-	<b>5</b> Reserved	<b>6</b> Reserved
<b>7</b> Red/Red & white DC+5V	<b>8</b> Black/Black & white GND	<b>9</b> Shield

The wire color of the servo drive is for reference only. Please refer to the real object.

(Encoder type is 17bit , 20bit):

<b>3</b> Reserved	<b>2</b> -	<b>1</b> White T+
<b>6</b> Reserved	<b>5</b> -	<b>4</b> White/Red T-
<b>9</b> Shield	<b>8</b> Blue GND	<b>7</b> Brown DC+5V

(Encoder type is 2500ppr, 33bit):

<b>3</b> Reserved	<b>2</b> Reserved	<b>1</b> White T+
<b>6</b> Reserved	<b>5</b> Reserved	<b>4</b> White/Red T-
<b>9</b> Shield	<b>8</b> Blue GND	<b>7</b> Brown DC+5V

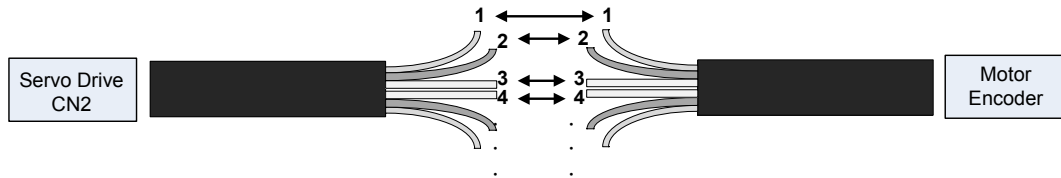

If not using housing and directly wire the cores, please follow the corresponding core number for wiring. For example, core number 1 from the servo drive CN2 should connect to core number 1 from the motor encoder; core number 2 from the servo drive CN2 should connect to core number 2 from the motor encoder and so on. Please number the cores from the servo drive in order and then connect it to the encoder.



Encoder Connection (Diagram 2):

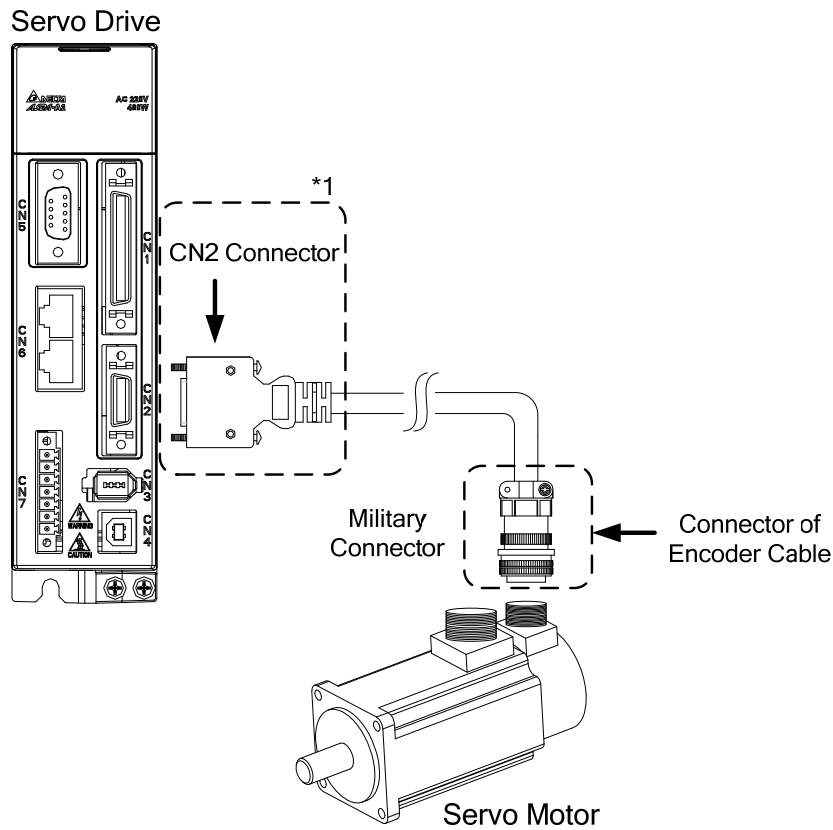

**NOTE**

This diagram shows the connection between the servo drive and the motor encoder. It is not drawn by the practical scale and specification will be different according to the selected servo drive and motor model.

Please refer to Section 3.5, CN2 Connector.

Motor Model	Connector of Encoder Cable			
ECMA-G△1303□S (300W)	<p>3106A-20-29S Military Connector</p>	Pin No.	Terminal Identification	Color
ECMA-E△1305□S (500W)		A	T+	Blue
ECMA-F△1305□S (500W)		B	T-	Blue & Black
ECMA-G△1306□S (600W)		S	DC+5V	Red/Red & White
ECMA-F△1308□S (850W)		R	GND	Black/Black & White
ECMA-G△1309□S (900W)		L	BRAID SHIELD	-
ECMA-C△1010□S (1000W)				
ECMA-E△1310□S (1000W)				
ECMA-F△1313□S (1300W)				
ECMA-E△1315□S (1500W)				
ECMA-F△1318□S (1800W)				
ECMA-C△1020□S (2000W)				
ECMA-E△1320□S (2000W)				
ECMA-E△1820□S (2000W)				
ECMA-C△1330□4 (3000W)				
ECMA-E△1830□S (3000W)				

ECMA-F△1830□S (3000W)		
ECMA-E△1835□S (3500W)		
ECMA-F△1845□S (4500W)		
ECMA-F△1855□3 (5500W)		
ECMA-F△1875□3 (7500W)		
ECMA-F1221B□3 (11kW)		
ECMA-F1221F□S (15kW)		

Please select shielded multi-core and the shielded cable should connect to the SHIELD end.  
Please refer to the description of Section 3.1.6.

**NOTE**

- 1) Box, (△) in servo motor model represents encoder type. △ = 1: incremental, 20-bit; △ = 2: incremental, 17-bit; △ = 3: 2500ppr; △ = A: absolute.
- 2) Box, (□) in servo motor model represents brake or keyway / oil seal.

### 3.1.6 Selection of Wiring Rod

The recommended wire rods are shown as the following table.

Servo Drive and corresponding Servo Motor		Power Wiring - Wire Diameter mm <sup>2</sup> (AWG)							
		L1c, L2c	R, S, T	U, V, W	P⊕, C				
ASD-A2-0121-□	ECMA-C1040F□S	1.3 (AWG16)	2.1 (AWG14)	0.82 (AWG18)	2.1 (AWG14)				
	ECMA-C△0401□S								
ASD-A2-0221-□	ECMA-C△0602□S								
ASD-A2-0421-□	ECMA-C△0604□S								
	ECMA-C△0604□H								
	ECMA-C△0804□7								
	ECMA-E△1305□S								
	ECMA-G△1303□S								
ASD-A2-0721-□	ECMA-F△1305□S								
	ECMA-C△0807□S								
	ECMA-C△0807□H								
	ECMA-C△0907□S								
	ECMA-G△1306□S								
ASD-A2-1021-□	ECMA-C△0910□S					1.3 (AWG16)	2.1 (AWG14)	1.3 (AWG16)	2.1 (AWG14)
	ECMA-C△1010□S								
	ECMA-E△1310□S								
	ECMA-F△1308□S								
	ECMA-G△1309□S								
ASD-A2-1521-□	ECMA-E△1315□S								
ASD-A2-2023-□	ECMA-C△1020□S	1.3 (AWG16)	2.1 (AWG14)	2.1 (AWG14)	2.1 (AWG14)				
	ECMA-E△1320□S								
	ECMA-E△1820□S	1.3 (AWG16)	2.1 (AWG14)	3.3 (AWG12)	2.1 (AWG14)				
	ECMA-F△1313□S								
	ECMA-F△1318□S								
ASD-A2-3023-□	ECMA-C△1330□S	1.3 (AWG16)	2.1 (AWG14)	3.3 (AWG12)	2.1 (AWG14)				
	ECMA-E△1830□S								
	ECMA-E△1835□S								
	ECMA-F△1830□S								
ASD-A2-4523-□	ECMA-F△1845□S	1.3 (AWG16)	3.3 (AWG12)	8.4 (AWG8)	3.3 (AWG12)				
ASD-A2-5523-□	ECMA-F△1855□3	1.3 (AWG16)	3.3 (AWG12)	13.3 (AWG6)	3.3 (AWG12)				
ASD-A2-7523-□	ECMA-F△1875□3	1.3 (AWG16)	5.3 (AWG10)	13.3 (AWG6)	3.3 (AWG12)				

ASD-A2-1B23-□	ECMA-F1221B□3	1.3 (AWG16)	8.4 (AWG8)	13.3 (AWG6)	8.4 (AWG8)
ASD-A2-1F23-□	ECMA-F1221F□S	1.3 (AWG16)	13.3 (AWG6)	21.2 (AWG4)	13.3 (AWG6)

Servo Drive Model	Encoder Wiring - Wire Diameter mm <sup>2</sup> (AWG)			
	Size	Number	Specification	Standard Length
ASD-A2-0121-□	0.13 (AWG26)	10 core (4 pair)	UL2464	3m (9.84ft.)
ASD-A2-0221-□				
ASD-A2-0421-□				
ASD-A2-0721-□				
ASD-A2-1021-□				
ASD-A2-1521-□				
ASD-A2-2023-□				
ASD-A2-3023-□				
ASD-A2-4523-□				
ASD-A2-5523-□				
ASD-A2-7523-□				
ASD-A2-1B23-□				
ASD-A2-1F23-□				

 **NOTE**

- 1) Please use shielded twisted-pair cable for encoder wiring so as to reduce the interference of the noise.
- 2) The shield should connect to the ⊕ phase of SHIELD.
- 3) Please follow the Selection of Wire Rod when wiring in order to avoid the danger it may occur.
- 4) Box, (□) at the end of the servo drive model represents the model code of ASDA-A2. Please refer to the model information of the product you purchased.
- 5) (△), in servo motor model represents encoder type. △ = 1: incremental type, 20-bit; △ = 2: incremental type, 17, bit; △ = 3: 2500 ppr; △ = A: absolute type.
- 6) Box, (□) in servo motor model represents brake or keyway / oil seal.

### 3.2 Connections - 400V series

#### 3.2.1 Connecting to Peripheral Devices

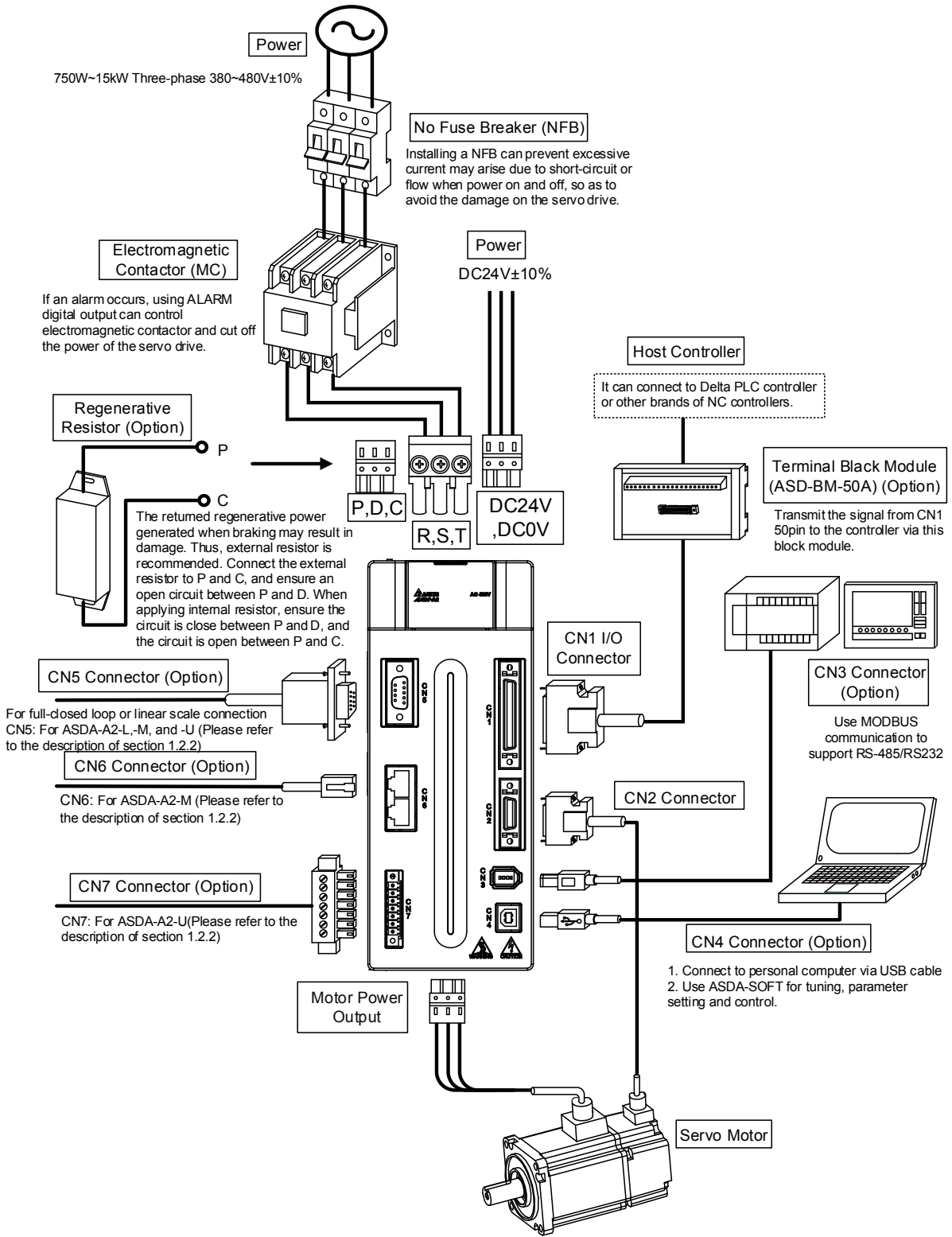

**Installation Notes:**

1. Check if the power and wiring among R, S, T and DC24V, DC0V are correct.  
Please refer to Chapter 11 for Specifications. Make sure the input voltage is correct, or it might damage the servo drive or danger may occur.
2. Check if the output terminal U, V, W of the servo motor is correctly wired. The incorrect wiring may disable the operation of the motor or cause the malfunction.
3. When applying to the external regenerative resistor, the contact between P<sup>+</sup> and D should be opened and the external regenerative resistor should connect to terminal P<sup>+</sup> and C. When applying to the internal regenerative resistor, the contact between P<sup>+</sup> and D should be closed and the contact between P<sup>+</sup> and C should be opened.
4. When an alarm occurs or the system is in emergency stop status, use ALARM or WARN to output and disconnect the power of magnetic contactor in order to disconnect the power of servo drive.

### 3.2.2 Connectors and Terminals of the Servo Drive

Terminal Signal	Name	Description													
<b>DC24V, DC0V</b>	Power input of the control circuit	Connect to single-phase AC power (select the appropriate voltage specification according to the product )													
<b>R, S, T</b>	Power input of the main circuit	Connect to three-phase AC power (select the appropriate voltage specification according to the product)													
<b>U, V, W</b> <b>FG (⊕)</b>	Motor cable	Connect to servo motor													
		<table border="1"> <thead> <tr> <th>Terminal Symbol</th> <th>Wire Color</th> <th>Description</th> </tr> </thead> <tbody> <tr> <td>U</td> <td>Red</td> <td rowspan="3">Three-phase main power cable of the motor</td> </tr> <tr> <td>V</td> <td>White</td> </tr> <tr> <td>W</td> <td>Black</td> </tr> <tr> <td>FG(⊕)</td> <td>Green</td> <td>Connect to the grounding ⊕ of the servo drive.</td> </tr> </tbody> </table>	Terminal Symbol	Wire Color	Description	U	Red	Three-phase main power cable of the motor	V	White	W	Black	FG(⊕)	Green	Connect to the grounding ⊕ of the servo drive.
		Terminal Symbol	Wire Color	Description											
		U	Red	Three-phase main power cable of the motor											
		V	White												
W	Black														
FG(⊕)	Green	Connect to the grounding ⊕ of the servo drive.													
<b>P<sup>+</sup>, D, C, ⊖</b>	Regenerative resistor terminal or braking unit	Internal resistor													
		External resistor													
		External braking unit													
	Ground terminal	Connect to the ground wire of the power and the servo motor.													
<b>CN1</b>	I/O connector (Option)	Connect to the host controller, please refer to Section 3.4.													
<b>CN2</b>	Connector (Option)	Connect to the encoder of the motor, please refer to Section 3.5.													
<b>CN3</b>	Connector (Option)	Connect to RS-485 or RS-232, please refer to Section 3.6													
<b>CN4</b>	USB connector (Type B) (Option)	Connect to personal computer (PC or NOTEBOOK), please refer to Section 3.7													
<b>CN5</b>	Connector (Option)	Connect to linear scale or encoder for full-closed loop and motor feedback. Please refer to Section 3.8.													

<b>CN6</b>	CANopen connector (Option)	RJ45 connector, please refer to Section 3.9
<b>CN7</b>	Extension DI connector (Option)	Extension DI connector. Please refer to 3.10.
<b>CN8</b>	Battery connector	Connector for absolute type of battery box

Pay special attention to the followings when wiring:

1. When the power is cutoff, do not touch R, S, T and U, V, W since the capacitance inside the servo drive still contains huge amount of electric charge. Wait until the charging light is off.
2. Separate R, S, T and U, V, W from the other wires. The interval should be at least 30 cm (11.8 inches).
3. If the wire of encoder CN2 or CN5 connector is not long enough, please use shielded twisted-pair cable which cannot exceed 20 meters (65.62 inches). If it exceeds 20 meters, please choose the bigger wire diameter of signal cable to ensure it will not cause signal fading. As for the encoder wiring specification of 20-meter-long cable, please use AWG26 of wire size and metal braided shield twisted-pair cable which complies with the standard of UL 2464.
4. When using CANopen, please use the standard shielded twisted-pair cables to ensure the communication quality.
5. When selecting the wire rod, please refer to Section 3.2.6.
6. Do not install the plug-in capacitance in servo drive. It might burn out the soft-start resistance and danger will occur.



### 3.2.3 Wiring Method

The wiring method of 400V servo drive is divided into single-phase and three-phase. In the diagram below, Power On is contact **a**, Power Off and ALRM\_RY are contact **b**. MC is the coil of magnetic contactor and self-remaining power and is the contact of main power circuit.

■ Wiring Method of Three-phase Power Supply (suitable for all series of 400 V servo drive)

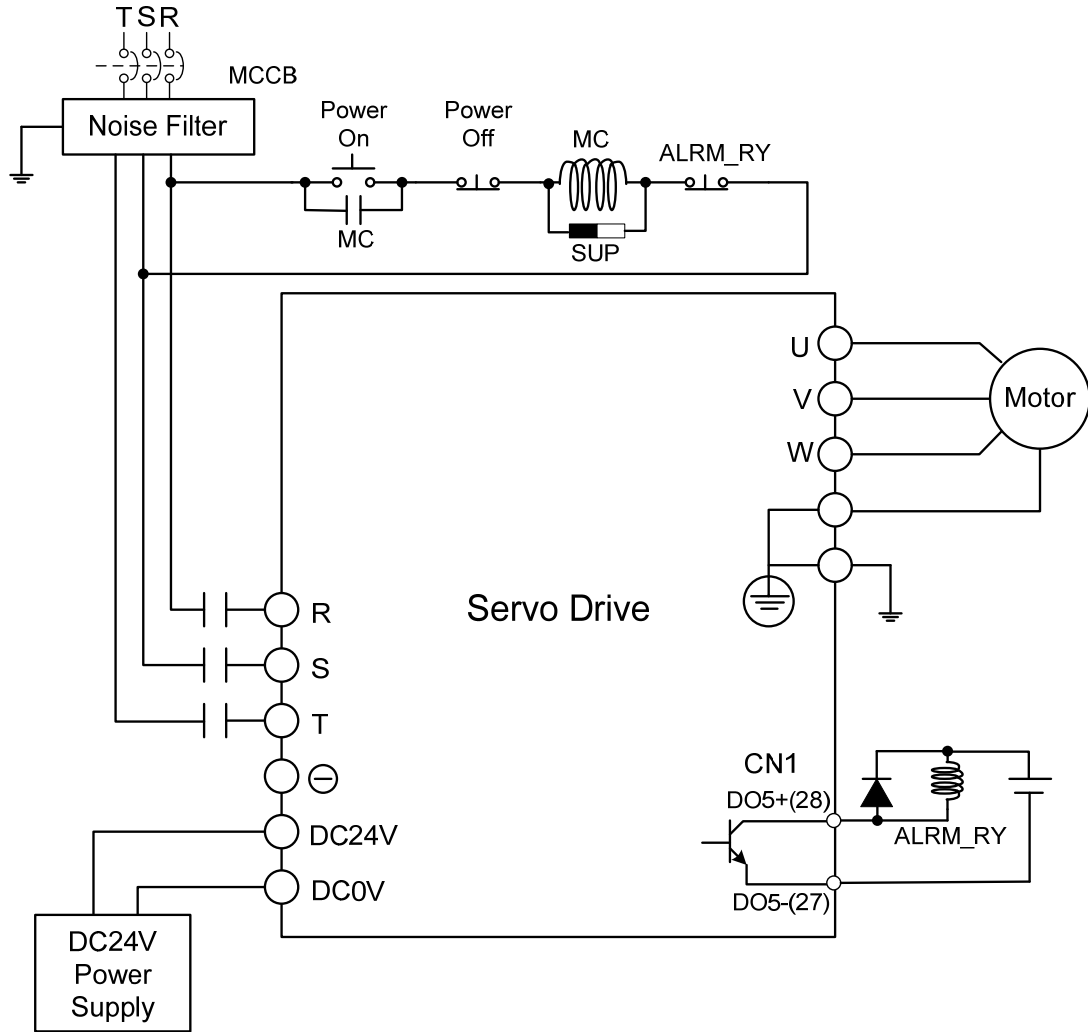

### 3.2.4 Specification of Motor Power Cable

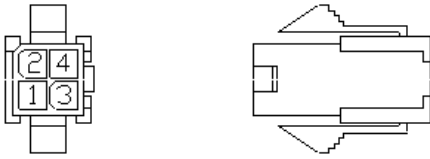
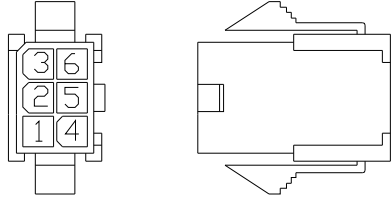
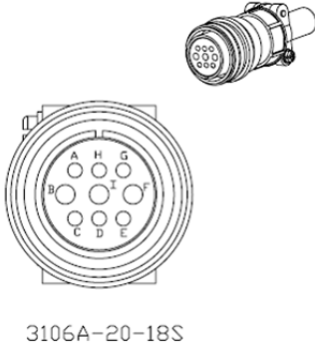
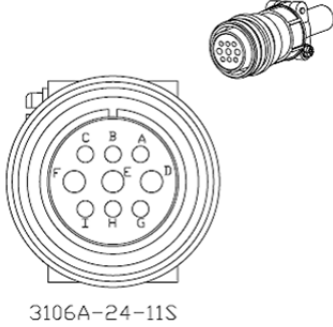
Motor Model	U, V, W / Connector of Brake	Terminal Definition
ECMA-J△0604□S (400W) ECMA-J△0807□S (750W) ECMA-J△0907□S (750W) ECMA-J△0910□S (1000W)		A
ECMA-J△0604□S (400W) ECMA-J△0807□S (750W) ECMA-J△0907□S (750W) ECMA-J△0910□S (1000W) *□ : with brake		B
ECMA-K△1305□S (500W) ECMA-L△1305□S (500W) ECMA-L△1308□S (850W) ECMA-M△1309□S (900W) ECMA-J△1010□S (1000W) ECMA-K△1310□S (1000W) ECMA-L△1313□S (1300W) ECMA-K△1315□S (1500W) ECMA-J△1020□S (2000W) ECMA-K△1320□S (2000W) ECMA-J△1330□4 (3000W)	 <p>3106A-20-18S</p>	C
ECMA-L△1830□S (3000W) ECMA-L△1845□S (4500W) ECMA-L△1855□3 (5500W) ECMA-L△1875□3 (7500W) ECMA-K△1820□S (2000W)	 <p>3106A-24-11S</p>	D

Wiring Name	U (Red)	V (White)	W (Black)	CASE GROUND (Green)	BRAKE1 (Yellow)	BRAKE2 (Blue)
A	1	2	3	4	-	-
B	1	2	4	5	3	6
C	F	I	B	E	G	H
D	D	E	F	G	A	B

When selecting the wire rod, please choose 600V PVC cable and the length should not longer than 30m. If the length exceeds 30m, please take the received voltage into consideration when selecting the wire size. Please refer to Section 3.1.6 for wire rod selection.

 **NOTE**

- 1 ) No polarity for brake coil, the wiring name is BRAKE1 & BRAKE2.
- 2 ) Power for brake is DC24 V. Never share it with the power of control signal VDD.
- 3 ) Box, ( $\Delta$ ) in servo motor model represents encoder type.  $\Delta$ = 1: incremental, 20-bit;  $\Delta$ = 2: incremental, 17-bit;  $\Delta$ = 3: 2500 ppr;  $\Delta$ = A: absolute.
- 4 ) Box, ( $\square$ ) in servo motor model represents brake or keyway / oil seal.

### 3.2.5 Specification of Encoder Connector

Encoder Connection (Diagram 1):

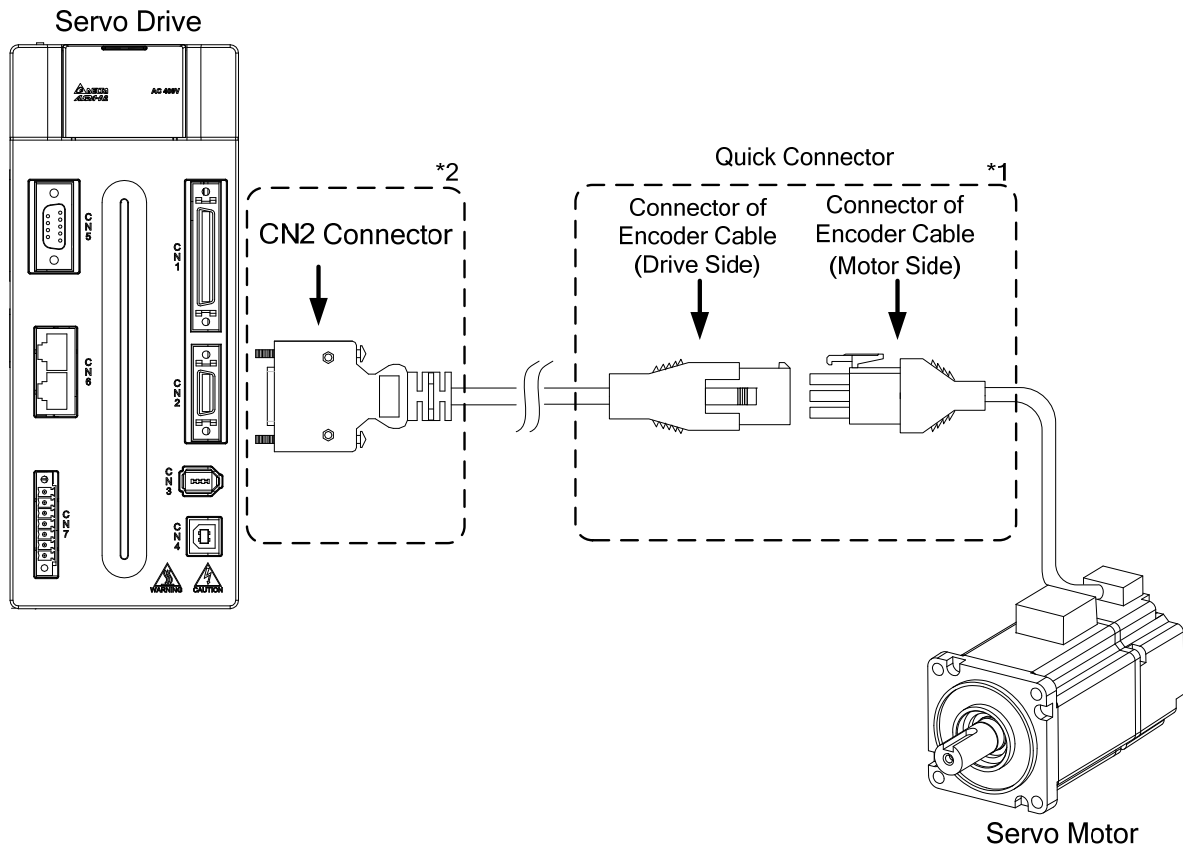

**NOTE**

This diagram shows the connection between the servo drive and the motor encoder. It is not drawn by the practical scale and specification will be different according to the selected servo drive and motor model.

- 1) Please refer to the Section of Specification and Definition of Encoder Connector.
- 2) Please refer to Section 3.5 CN2 Connector.

Motor Model	Connector of Encoder Cable
ECMA-J△0604□S (400W) ECMA-J△0807□S (750W) ECMA-J△0907□S (750W) ECMA-J△0910□S (1000W)	<p>The diagram shows the pin configuration of the encoder cable connector. It consists of two views: 'View from this side' (drive side) and 'View from this side' (motor side). The drive side view shows a 9-pin connector with pins numbered 9, 6, 3, 8, 5, 2, 7, 4, 1. The motor side view shows a 9-pin connector with pins numbered 3, 6, 9, 2, 5, 8, 1, 4, 7.</p>

Encoder Connection (Diagram 2):

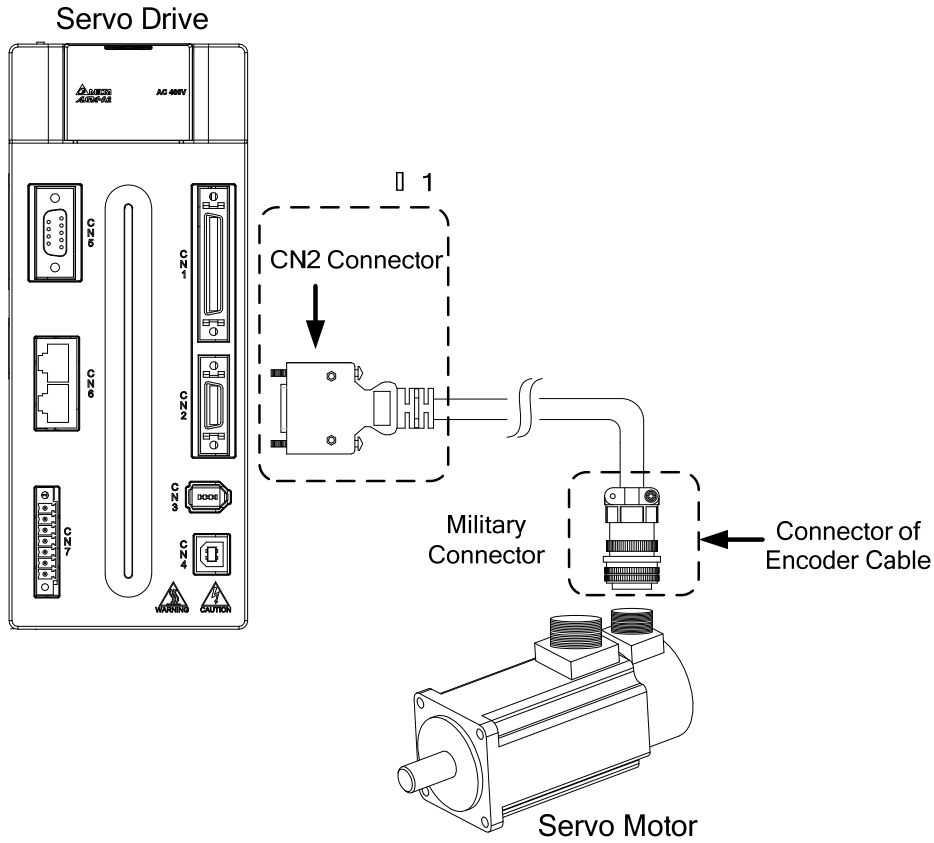

**NOTE**

This diagram shows the connection between the servo drive and the motor encoder. It is not drawn by the practical scale and specification will be different according to the selected servo drive and motor model.

Please refer to Section 3.5, CN2 Connector.

Motor Model	Connector of Encoder Cable																		
ECMA-K△1305□S (500W) ECMA-L△1305□S (500W) ECMA-L△1308□S (850W) ECMA-M△1309□S (900W) ECMA-J△1010□S (1000W) ECMA-K△1310□S (1000W) ECMA-L△1313□S (1300W) ECMA-K△1315□S (1500W) ECMA-J△1020□S (2000W) ECMA-K△1320□S (2000W) ECMA-J△1330□4 (3000W)	<p>3106A-20-29S Military Connector</p> <table border="1"> <thead> <tr> <th>Pin No.</th> <th>Terminal Identification</th> <th>Color</th> </tr> </thead> <tbody> <tr> <td>A</td> <td>T+</td> <td>Blue</td> </tr> <tr> <td>B</td> <td>T-</td> <td>Blue &amp; Black</td> </tr> <tr> <td>S</td> <td>DC+5V</td> <td>Red/Red &amp; White</td> </tr> <tr> <td>R</td> <td>GND</td> <td>Black/Black &amp; White</td> </tr> <tr> <td>L</td> <td>BRAID SHIELD</td> <td>-</td> </tr> </tbody> </table>	Pin No.	Terminal Identification	Color	A	T+	Blue	B	T-	Blue & Black	S	DC+5V	Red/Red & White	R	GND	Black/Black & White	L	BRAID SHIELD	-
Pin No.	Terminal Identification	Color																	
A	T+	Blue																	
B	T-	Blue & Black																	
S	DC+5V	Red/Red & White																	
R	GND	Black/Black & White																	
L	BRAID SHIELD	-																	

Please select shielded multi-core and the shielded cable should connect to the SHIELD end.

Please refer to the description of Section 3.1.6.

**NOTE**

- 1) Box, ( $\triangle$ ) in servo motor model represents encoder type.  $\triangle = 1$ : incremental, 20-bit;  $\triangle = 2$ : incremental, 17-bit;  $\triangle = 3$ : 2500 ppr;  $\triangle = A$ : absolute
- 2) Box, ( $\square$ ) in servo motor model represents brake or keyway / oil seal.

### 3.2.6 Selection of Wiring Rod

Servo Drive and corresponding Servo Motor		Power Wiring - Wire Diameter mm <sup>2</sup> (AWG)			
		DC24V, DC0V	R, S, T	U, V, W	P <sup>+</sup> , C
ASD-A2-0743- $\square$	ECMA-J $\triangle$ 0604 $\square$ S	1.3 (AWG16)	0.82 (AWG18)	0.82 (AWG18)	2.1 (AWG14)
	ECMA-J $\triangle$ 0807 $\square$ S				
	ECMA-J $\triangle$ 0907 $\square$ S				
	ECMA-K $\triangle$ 1305 $\square$ S				
	ECMA-L $\triangle$ 1305 $\square$ S				
ASD-A2-1043- $\square$	ECMA-J $\triangle$ 0910 $\square$ S				
	ECMA-K $\triangle$ 1310 $\square$ S				
	ECMA-L $\triangle$ 1308 $\square$ S				
ASD-A2-1543- $\square$	ECMA-J $\triangle$ 1010 $\square$ S	1.3 (AWG16)	0.82 (AWG18)	1.3 (AWG16)	2.1 (AWG14)
	ECMA-K $\triangle$ 1315 $\square$ S				
	ECMA-M $\triangle$ 1309 $\square$ S				
	ECMA-L $\triangle$ 1313 $\square$ S				
ASD-A2-2043- $\square$	ECMA-J $\triangle$ 1020 $\square$ S				
	ECMA-K $\triangle$ 1320 $\square$ S				
	ECMA-K $\triangle$ 1820 $\square$ S				
ASD-A2-3043- $\square$	ECMA-L $\triangle$ 1830 $\square$ S	1.3 (AWG16)	1.3 (AWG16)	1.3 (AWG16)	2.1 (AWG14)
	ECMA-J $\triangle$ 1330 $\square$ 4				
ASD-A2-4543- $\square$	ECMA-L $\triangle$ 1845 $\square$ S	1.3 (AWG16)	2.1 (AWG14)	3.3 (AWG12)	3.3 (AWG12)
ASD-A2-5543- $\square$	ECMA-L $\triangle$ 1855 $\square$ 3				
ASD-A2-7543- $\square$	ECMA-L $\triangle$ 1875 $\square$ 3	1.3 (AWG16)	3.3 (AWG12)	5.3 (AWG10)	3.3 (AWG12)

Servo Drive Model	Encoder Wiring - Wire Diameter mm <sup>2</sup> (AWG)			
	Size	Number	Specification	Standard Length
ASD-A2-0743-□	0.13 (AWG26)	10 core (4 pair)	UL2464	3m (9.84ft.)
ASD-A2-1043-□				
ASD-A2-1543-□				
ASD-A2-2043-□				
ASD-A2-3043-□				
ASD-A2-4543-□				
ASD-A2-5543-□				
ASD-A2-7543-□				

 **NOTE**

- 1) Box, (□) at the end of the servo drive model represents the model code of ASDA-A2. Please refer to the model information of the product you purchased.
- 2) (△), in servo motor model represents encoder type. △ = 1: incremental type, 20-bit; △ = 2: incremental type, 17, bit; △ = 3: 2500 ppr; △ = A: absolute type.
- 3) Box, (□) in servo motor model represents brake or keyway / oil seal.
- 4) Please use shielded twisted-pair cable for encoder wiring so as to reduce the interference of the noise.
- 5) The shield should connect to the ⊕ phase of SHIELD.
- 6) Please follow the Selection of Wire Rod when wiring in order to avoid the danger it may occur.

### 3.3 Basic Wiring

#### 3.3.1 220V series

- 200W (included) or models below (without built-in regenerative resistor)

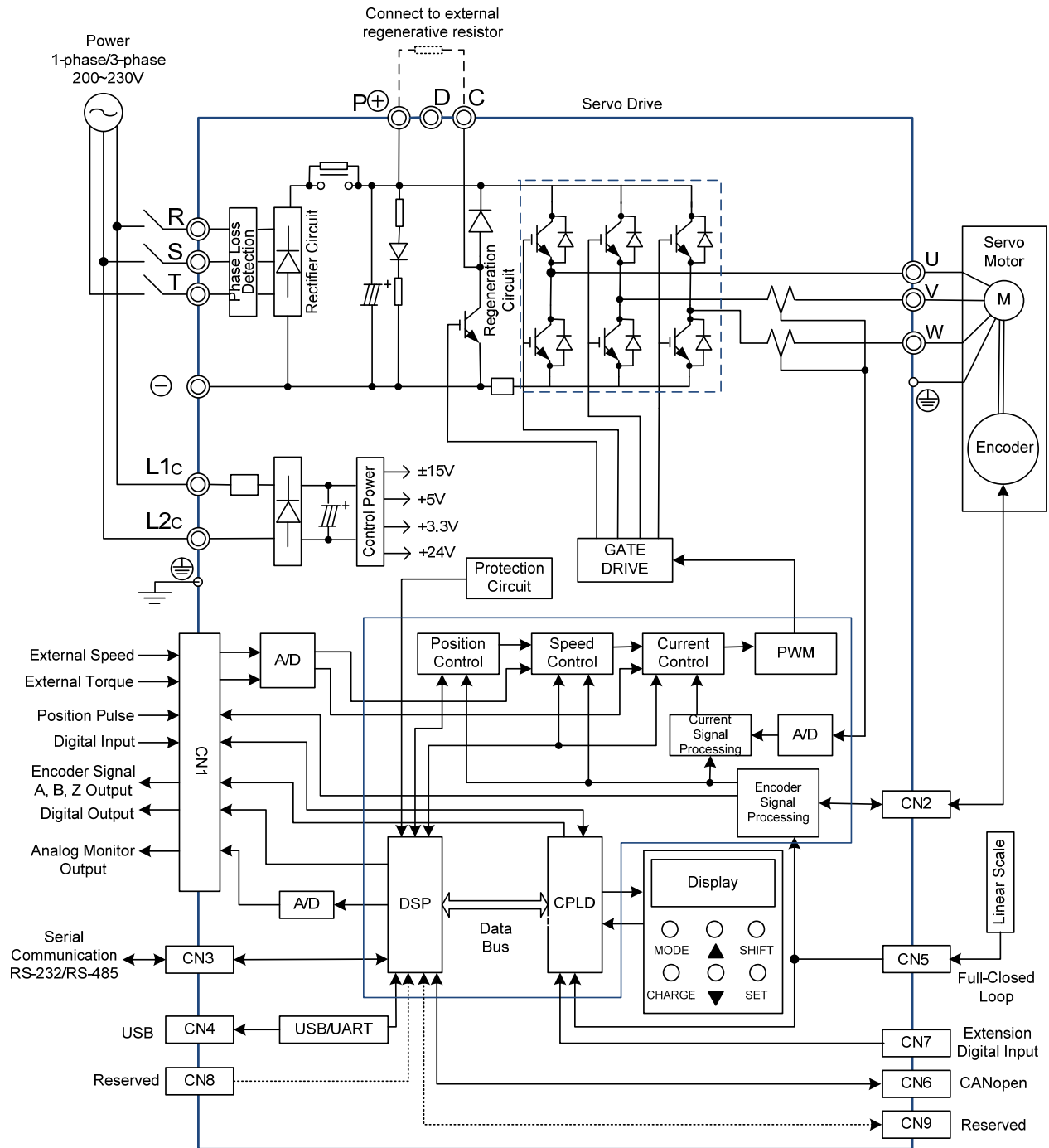



■ 400W ~ 4.5 kW models (with built-in regenerative resistor)

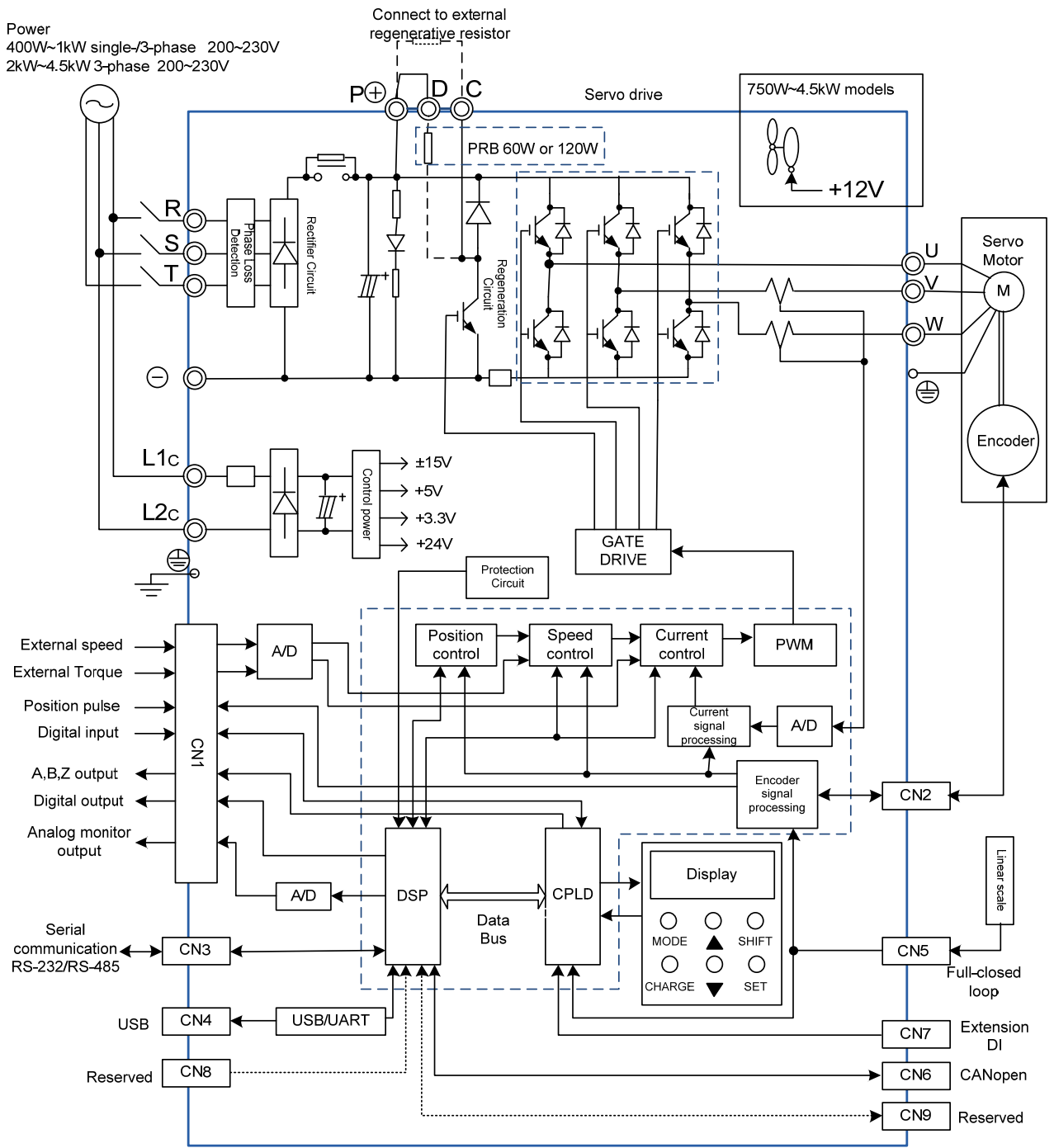

■ 5.5kW to 15kW models (with built-in fan but no regenerative resistor)

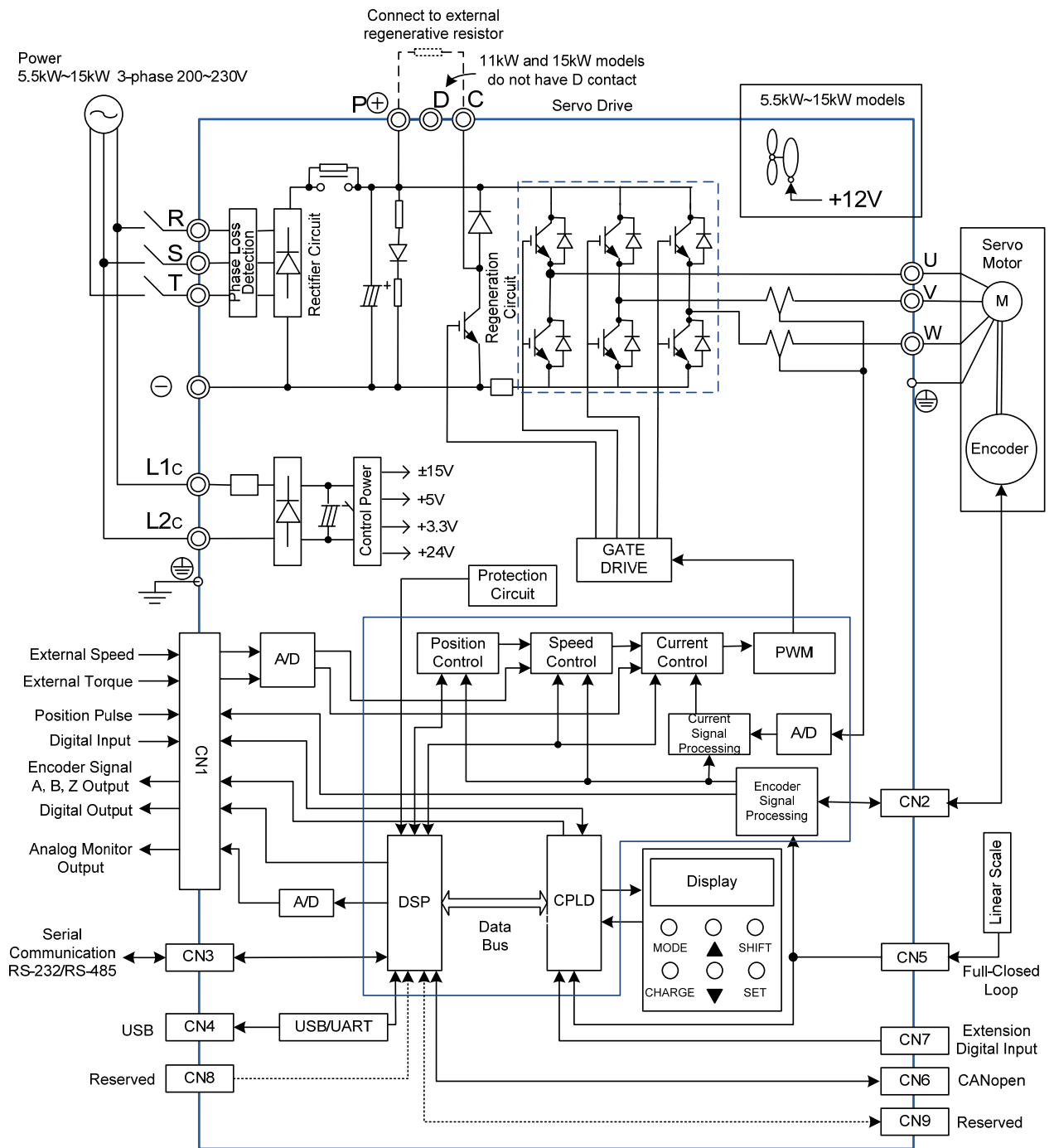

### 3.3.2 400V series

- 750W to 1.5kW models (with built-in regenerative resistor and fan)

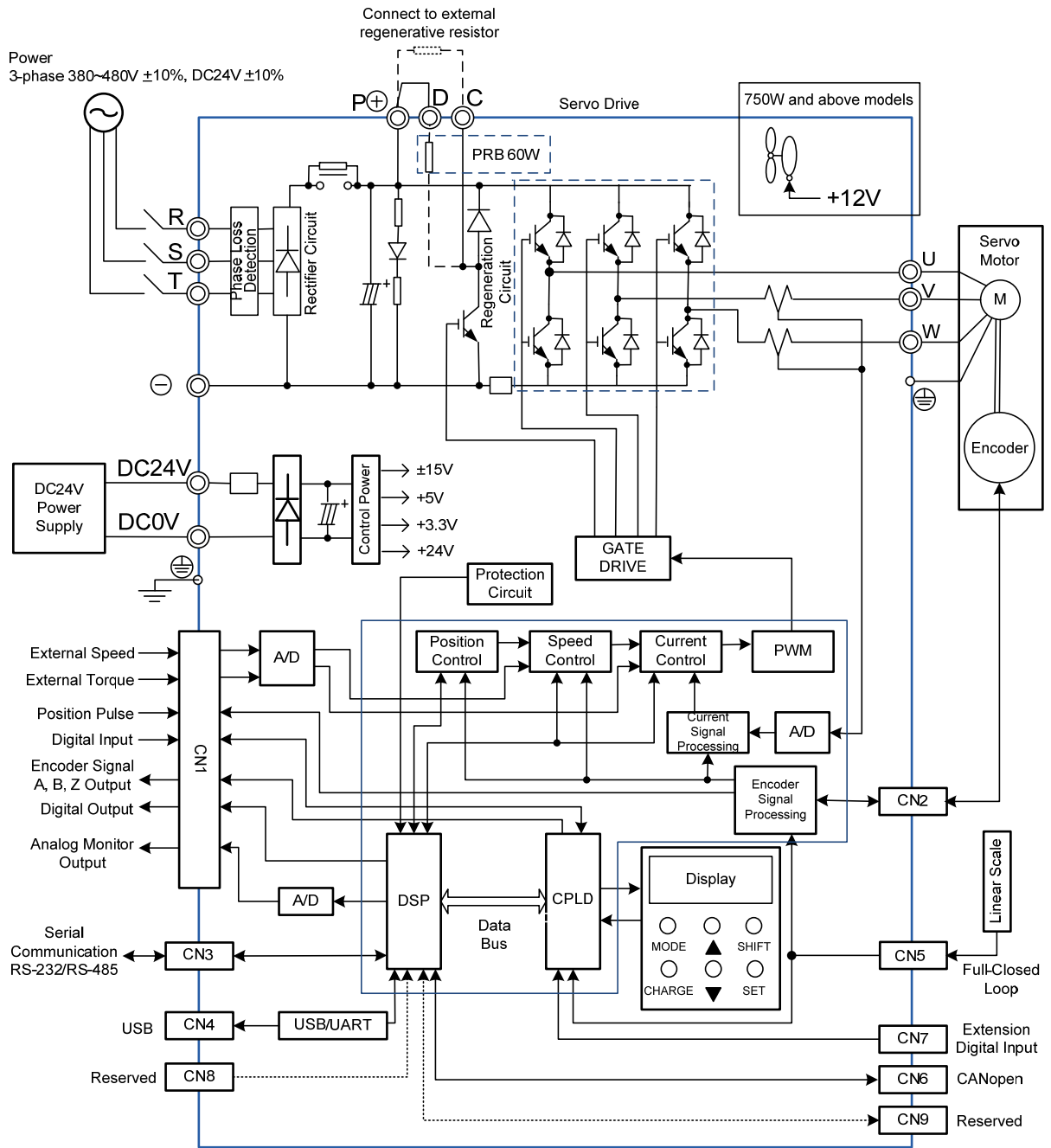

■ 2kW to 7.5kW models (with built-in fan but no regenerative resistor)

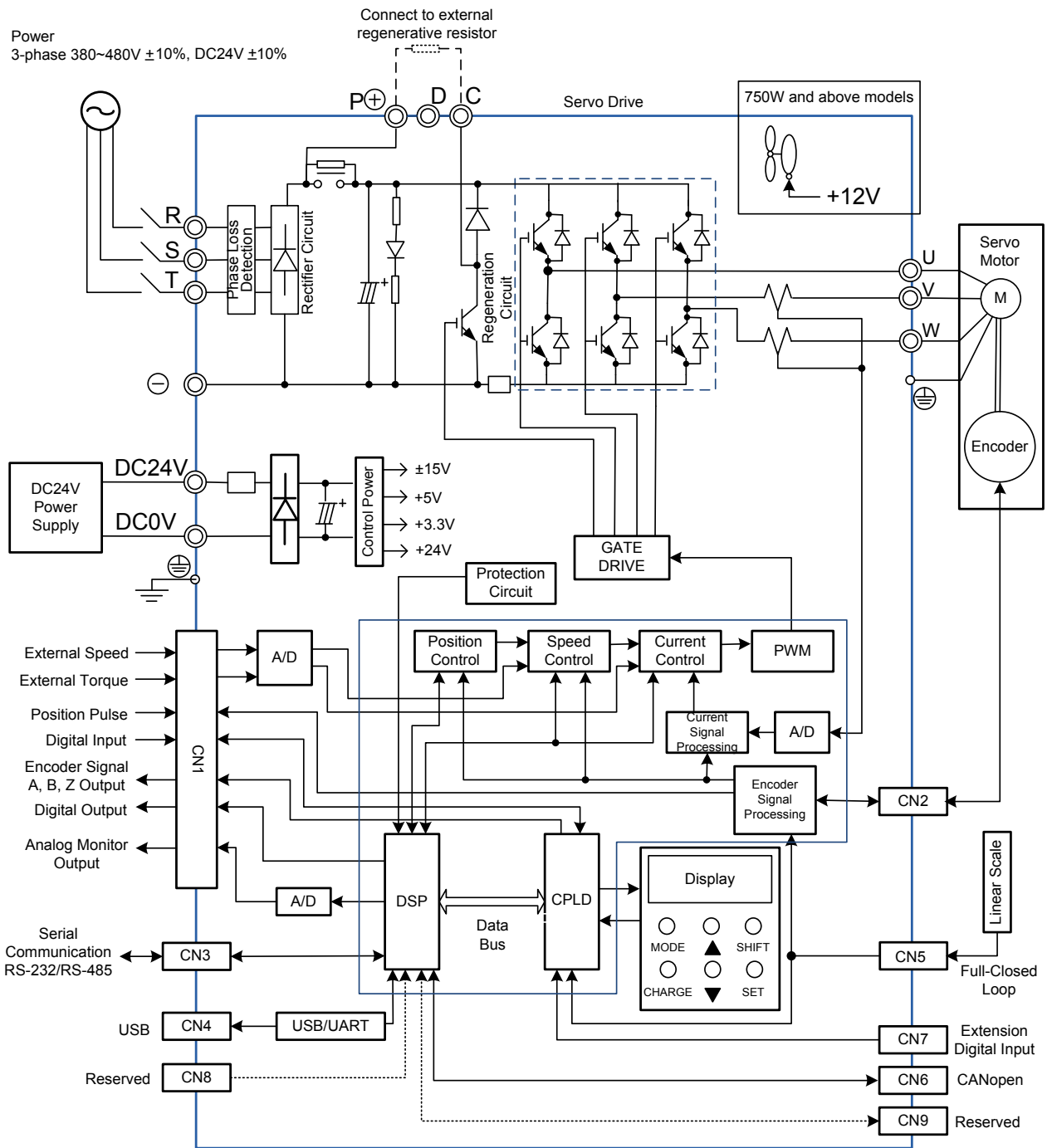

### 3.4 I/O Signal (CN1) Connection

#### 3.4.1 I/O Signal (CN1) Connector Terminal Layout

In order to have a more flexible communication with the master, 5 programmable Digital Outputs (DO) and 8 programmable Digital Inputs (DI) are provided. The setting of 8 digital inputs and 5 digital outputs of each axis are parameter P2-10~P2-17 and parameter P2-18~P2-22 respectively. In addition, the differential output encoder signal, A+, A-, B+, B-, Z+ and Z-, input of analog torque command, analog speed/position command and pulse position command are also provided. The followings are the pin diagrams.



CN1 Connector (female)

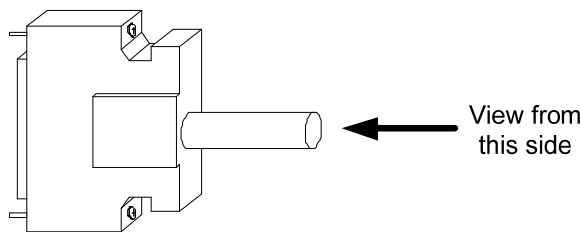

26	DO4-	DO5+	DI8-	DI6-	DI3-	SIGN	HPulse	/HSIGN	V_REF	GND	HSIGN	OCZ	OZ	50
27	DO5-	/HPulse	DI7-	DI5-	PULLHLS	/SIGN	PULLHP	/PULSE	PULSE	COM-	COM-	COM-	49	
1	DO4+	DO3+	DO2+	DO1+	DI1-	COM+	GND	MON2	VDD	GND	OA	/OB	OB	25
2	DO3-	DO2-	DO1-	DI4-	DI2-	GND	NC	MON1	T_REF	VCC	/OA	/OZ	24	

The rear wiring terminal of CN1 connector

2	DO3-	Digital output	1	DO4+	Digital output	27	DO5-	Digital output	26	DO4-	Digital output
4	DO2-	Digital output	3	DO3+	Digital output	29	/HPULSE	High-speed position pulse (-)	28	DO5+	Digital output
6	DO1-	Digital output	5	DO2+	Digital output	31	DI7-	Digital input	30	DI8-	Digital input
8	DI4-	Digital input	7	DO1+	Digital output	33	DI5-	Digital input	32	DI6-	Digital input
10	DI2-	Digital input	9	DI1-	Digital input	35	PULL HI_S (SIGN)	Pulse applied power (SIGN)	34	DI3-	Digital input
12	GND	Analog input signal ground	11	COM+	Power input (12~24V)	37	/SIGN	Position sign (-)	36	SIGN	Position sign (+)
14	NC	No Connection	13	GND	Analog input signal ground	39	PULL HI_P (PULSE)	Pulse applied Power (PULSE)	38	HPULSE	High-speed position pulse (+)
16	MON1	Analog monitor output 1	15	MON2	Analog monitor output 2	41	/PULSE	Pulse input (-)	40	/HSIGN	High-speed position sign (-)
18	T_REF	Analog torque Input	17	VDD	+24V power output (for external I/O)	43	PULSE	Pulse input (+)	42	V_REF	Analog speed input (+)
20	VCC	+12V power output (for analog command)	19	GND	Analog input signal ground	45	COM-	VDD(24V) power ground	44	GND	Analog input signal ground
22	/OA	Encoder /A pulse output	21	OA	Encoder A pulse output	47	COM-	VDD(24V) power ground	46	HSIGN	High-speed position sign (+)
24	/OZ	Encoder /Z pulse output	23	/OB	Encoder /B pulse output	49	COM-	VDD(24V) power ground	48	OCZ	Encoder Z pulse open-collector output
			25	OB	Encoder B pulse output				50	OZ	Encoder Z pulse line-driver output

**NOTE**

NC means NO CONNECTION. This terminal is for internal use only. Do not connect it, or it may damage the servo drive.

### 3.4.2 Signals Explanation of Connector CN1

The following details the signals listed in previous section:

#### General Signals

Signal		Pin No	Function	Wiring Method (Refer to 3.4.3)
Analog Command (input)	V_REF	42	(1) The speed command of the motor is -10 V ~ +10 V which means the speed command is -3000 ~ +3000 r/min (default). It can change the corresponding range via parameters. (2) The position command of the motor is -10 V ~ +10 V which means the position command is -3 cycles ~ +3 cycles (default).	C1
	T_REF	18	The torque command of the motor is -10 V ~ +10 V which means the rated torque command of -100 % ~ +100 %.	C1
Analog Monitor (output)	MON1 MON2	16 15	The operating state of the motor can be shown by analog voltage, such as speed and current. This drive provides two channel outputs. Users can select the desired monitoring data via parameter P0-03. This signal is based on the power ground.	C2
Position Pulse (input)	PULSE /PULSE SIGN /SIGN PULL HI_P PULL HI_S	43	Position pulse can be inputted by Line Driver (single phase max. frequency 500KHz) or open-collector (single phase max. frequency 200 KHz). Three kinds of command type can be selected via P1-00, CW pulse + CCW pulse, pulse + direction, A pulse + B pulse. When position pulse uses open-collector, the terminal should be connected to an external applied power in order to pull high.	C3/C4
		41 36 37 39 35		C3/C4
High-speed Position Pulse (input)	HPULSE /HPULSE HSIGN /HSIGN	38 29 46 40	Position pulse can be inputted by Line Driver (single phase max. frequency 500KHz) or open-collector (single phase max. frequency 200 KHz). Three kinds of command type can be selected via P1-00, CW pulse + CCW pulse, pulse + direction, A pulse + B pulse. When position pulse uses open-collector, the terminal should be connected to an external applied power in order to pull high.	C4-2
Position Pulse (output)	OA /OA	21 22	Encoder signal output A, B, Z (Line Drive output)	C13/C14
	OB /OB	25 23		
	OZ /OZ	50 24		
	OCZ	48	Encoder signal output Z (Open-collector output)	-

Power	VDD	17	VDD is the +24 V power provided by the drive and is for Digital Input (DI) and Digital Output (DO) signal. The maximum current is 500 mA.	-
	COM+ COM-	11 45 47 49	COM+ is the common input of Digital Input (DI) and Digital Output (DO) voltage. When using VDD, VDD should be connected to COM+. If not using, it needs to apply the external power (+12 V ~ + 24 V). Its positive end should connect to COM+ and the negative end should connect to COM-.	
	VCC	20	VCC is the +12V power provided by the drive. It is used for providing the simple analog command (speed or torque command). The maximum current is 100 mA.	
	GND	12, 13, 19, 44	VCC voltage is based on GND.	
Other	NC	14	NO CONNECTION. This terminal is for internal use only. Do not connect it, or it may damage the servo drive.	

There are numerous operation mode of this servo drive (please refer to Chapter 6.1). Each operation mode needs different I/O signal. In order to use the terminal in a more efficient way, the selection of I/O signal has to be programmable. That is to say, users can choose the desired DI/DO signal to meet the demand. Basically, the default setting of DI/DO signal has already have the appropriate function which can satisfy the demand of normal application.

Users have to select the operation mode based on the needs first (please refer to Chapter 6.1 for the introduction of each mode) and refer to the following DI/DO table to know the corresponding default setting of DI/DO signal and Pin No of the selected mode in order to conduct the wiring.

The table below lists the default setting of DI/DO signal function and pin No:

**The explanation of DO signal default setting is as the followings.**

DO Signal Name	Operation Mode	Pin No.		Details	Wiring Method (Refer to 3.4.3)
		+	-		
SRDY	ALL	7	6	When the servo drive applies to the power and no alarm (ALRM) occurs in control circuit and motor power circuit, this DO is ON.	C5/C6/C7/ C8
SON	N/A	-	-	When the DI.SON is ON and the motor servo circuit can operate smoothly, this DO is ON.	
ZSPD	ALL	5	4	When the motor speed is slower than the setting value of parameter P1-38, this DO is ON.	
TSPD	ALL (except PT, PR)	-	-	When the motor actual speed (r/min) is faster than the setting value of parameter P1-39, this DO is ON.	



DO Signal Name	Operation Mode	Pin No.		Details	Wiring Method (Refer to 3.4.3)
		+	-		
TPOS	PT, PR, PT-S, PT-T, PR-S, PR-T	1	26	When the deviation between the motor command and actual position (PULSE) is smaller than the setting value of parameter P1-54, this DO is ON.	C5/C6/C7/ C8
TQL	N/A	-	-	When torque is limiting, this DO is ON.	
ALRM	ALL	28	27	When the alarm occurs (except forward/reverse limit, emergency stop, communication error, under voltage), this DO is ON.	
BRKR	ALL	-	-	Control contact of brake.	
HOME	ALL	3	2	When homing is completed, this DO is ON.	
OLW	ALL	-	-	When the overload level is reached, this DO is ON.	
WARN	ALL	-	-	A warning occurs. When it is in the status of forward/reverse limit, emergency stop, communication error, under voltage, this DO is ON.	
OVF	PT, PR	-	-	Position command /feedback overflows	
SNL (SCWL)	PR	-	-	Reverse software limit	
SPL (SCCWL)	PR	-	-	Forward software limit	
Cmd_OK	PR	-	-	The output of internal position command is completed.	
CAP_OK	PR	-	-	CAPTURE procedure is completed.	
MC_OK	PR	-	-	When DO.Cmd_OK and TPOS are ON, this DO is ON.	
CAM_AREA	PR	-	-	The master position of E-CAM is inside the setting area.	
S_CMP	S, Sz	-	-	When the deviation between the speed command and the feedback speed of the motor is smaller than the setting value of parameter P1-47, this DO is ON.	
SDO_0	ALL	-	-	Output the status of bit00 of P4-06	
SDO_1	ALL	-	-	Output the status of bit01 of P4-06	
SDO_2	ALL	-	-	Output the status of bit02 of P4-06	
SDO_3	ALL	-	-	Output the status of bit03 of P4-06	
SDO_4	ALL	-	-	Output the status of bit04 of P4-06	
SDO_5	ALL	-	-	Output the status of bit05 of P4-06	
SDO_6	ALL	-	-	Output the status of bit06 of P4-06	
SDO_7	ALL	-	-	Output the status of bit07 of P4-06	
SDO_8	ALL	-	-	Output the status of bit08 of P4-06	

DO Signal Name	Operation Mode	Pin No.		Details	Wiring Method (Refer to 3.4.3)
		+	-		
SDO_9	ALL	-	-	Output the status of bit09 of P4-06	C5/C6/C7/ C8
SDO_A	ALL	-	-	Output the status of bit10 of P4-06	
SDO_B	ALL	-	-	Output the status of bit11 of P4-06	
SDO_C	ALL	-	-	Output the status of bit12 of P4-06	
SDO_D	ALL	-	-	Output the status of bit13 of P4-06	
SDO_E	ALL	-	-	Output the status of bit14 of P4-06	
SDO_F	ALL	-	-	Output the status of bit15 of P4-06	

 **NOTE**

- 1 ) For example, if the user selects PR mode, pin 3 and 2 are HOME. If the user selects S mode, pin 3 and 2 are TSPD.
- 2 ) The unlisted Pin No means the signal is not the preset one. If users want to use it, parameters need to be changed and set as the desired ones. Please refer to Section 3.4.4 for further details.

**The explanation of DI signal default setting is as the followings**

DI Signal Name	Operation Mode	Pin No.	Function	Wiring Method (Refer to 3.4.3)
SON	ALL	9	When DI is ON, the servo circuit will be activated and the motor coil will generate current.	C9/C10/C 11 /C12
ARST	ALL	33	When the alarm (ALRM) occurs, this signal is used to reset the servo drive and output the signal, Ready (SRDY) again.	
GAINUP	ALL	-	It is for switching the controller gain.	
CCLR	PT, PR	10	It is for clearing the deviation counter.	
ZCLAMP	ALL	-	When this DI is ON and the motor speed is slower than the setting of P1-38, the motor position will be locked when the signal is triggered.	
CMDINV	PR, T, S	-	When this DI is ON, the motor will operate in the opposite direction.	
CTRG	PR, PR-S, PR-T	10	In PR mode, the moment CTRG is ON (rising edge), save the position command selected by POS0~2 into the controller and then trigger the command.	
TRQLM	S, Sz	10	ON means the torque limit command is effective.	

DI Signal Name	Operation Mode	Pin No.	Function	Wiring Method (Refer to 3.4.3)																																																																																																																					
SPDLM	T, Tz	10	ON means the speed limit command is effective.	C9/C10/ C11/C12																																																																																																																					
POS0	P, PR, PR-S, PR-T	34	In PR mode, the source of position command:																																																																																																																						
POS1		8	<table border="1"> <thead> <tr> <th>Position command</th> <th>POS 5</th> <th>POS 4</th> <th>POS 3</th> <th>POS 2</th> <th>POS 1</th> <th>POS0</th> <th>CTRG</th> <th>Corresponding parameter</th> </tr> </thead> <tbody> <tr> <td>P1</td> <td>0</td> <td>0</td> <td>0</td> <td>0</td> <td>0</td> <td>0</td> <td>↑</td> <td>P6-00</td> </tr> <tr> <td></td> <td></td> <td></td> <td></td> <td></td> <td></td> <td></td> <td></td> <td>P6-01</td> </tr> <tr> <td>P2</td> <td>0</td> <td>0</td> <td>0</td> <td>0</td> <td>0</td> <td>1</td> <td>↑</td> <td>P6-02</td> </tr> <tr> <td></td> <td></td> <td></td> <td></td> <td></td> <td></td> <td></td> <td></td> <td>P6-03</td> </tr> <tr> <td>~</td> <td></td> <td></td> <td></td> <td></td> <td></td> <td></td> <td></td> <td>~</td> </tr> <tr> <td>P50</td> <td>1</td> <td>1</td> <td>0</td> <td>0</td> <td>1</td> <td>0</td> <td>↑</td> <td>P6-98</td> </tr> <tr> <td></td> <td></td> <td></td> <td></td> <td></td> <td></td> <td></td> <td></td> <td>P6-99</td> </tr> <tr> <td>P51</td> <td>1</td> <td>1</td> <td>0</td> <td>0</td> <td>1</td> <td>1</td> <td>↑</td> <td>P7-00</td> </tr> <tr> <td></td> <td></td> <td></td> <td></td> <td></td> <td></td> <td></td> <td></td> <td>P7-01</td> </tr> <tr> <td>~</td> <td></td> <td></td> <td></td> <td></td> <td></td> <td></td> <td></td> <td>~</td> </tr> <tr> <td>P64</td> <td>1</td> <td>1</td> <td>1</td> <td>1</td> <td>1</td> <td>1</td> <td>↑</td> <td>P7-26</td> </tr> <tr> <td></td> <td></td> <td></td> <td></td> <td></td> <td></td> <td></td> <td></td> <td>P7-27</td> </tr> </tbody> </table>		Position command	POS 5	POS 4	POS 3	POS 2	POS 1	POS0	CTRG	Corresponding parameter	P1	0	0	0	0	0	0	↑	P6-00									P6-01	P2	0	0	0	0	0	1	↑	P6-02									P6-03	~								~	P50	1	1	0	0	1	0	↑	P6-98									P6-99	P51	1	1	0	0	1	1	↑	P7-00									P7-01	~								~	P64	1	1	1	1	1	1	↑	P7-26									P7-27
Position command		POS 5	POS 4		POS 3	POS 2	POS 1	POS0	CTRG	Corresponding parameter																																																																																																															
P1		0	0		0	0	0	0	↑	P6-00																																																																																																															
										P6-01																																																																																																															
P2		0	0		0	0	0	1	↑	P6-02																																																																																																															
										P6-03																																																																																																															
~										~																																																																																																															
P50		1	1		0	0	1	0	↑	P6-98																																																																																																															
										P6-99																																																																																																															
P51	1	1	0		0	1	1	↑	P7-00																																																																																																																
									P7-01																																																																																																																
~									~																																																																																																																
P64	1	1	1		1	1	1	↑	P7-26																																																																																																																
									P7-27																																																																																																																
STOP	-	-	Stop																																																																																																																						
SPD0	S, Sz, PT-S, PR-S, S-T	34	The source of selecting speed command:																																																																																																																						
SPD1		8	<table border="1"> <thead> <tr> <th>SPD1</th> <th>SPD0</th> <th>Command source</th> </tr> </thead> <tbody> <tr> <td>0</td> <td>0</td> <td>S mode is analog input; Sz mode is 0</td> </tr> <tr> <td>0</td> <td>1</td> <td>P1-09</td> </tr> <tr> <td>1</td> <td>0</td> <td>P1-10</td> </tr> <tr> <td>1</td> <td>1</td> <td>P1-11</td> </tr> </tbody> </table>		SPD1	SPD0	Command source	0	0	S mode is analog input; Sz mode is 0	0	1	P1-09	1	0	P1-10	1	1	P1-11																																																																																																						
SPD1		SPD0	Command source																																																																																																																						
0		0	S mode is analog input; Sz mode is 0																																																																																																																						
0		1	P1-09																																																																																																																						
1	0	P1-10																																																																																																																							
1	1	P1-11																																																																																																																							
TCM0	PT, T, Tz, PT-T, PR-T, S-T	34	The source of selecting torque command:																																																																																																																						
TCM1		8	<table border="1"> <thead> <tr> <th>TCM1</th> <th>TCM0</th> <th>Command source</th> </tr> </thead> <tbody> <tr> <td>0</td> <td>0</td> <td>T mode is analog input; Tz mode is 0</td> </tr> <tr> <td>0</td> <td>1</td> <td>P1-12</td> </tr> <tr> <td>1</td> <td>0</td> <td>P1-13</td> </tr> <tr> <td>1</td> <td>1</td> <td>P1-14</td> </tr> </tbody> </table>	TCM1	TCM0	Command source	0	0	T mode is analog input; Tz mode is 0	0	1	P1-12	1	0	P1-13	1	1	P1-14																																																																																																							
TCM1		TCM0	Command source																																																																																																																						
0		0	T mode is analog input; Tz mode is 0																																																																																																																						
0		1	P1-12																																																																																																																						
1	0	P1-13																																																																																																																							
1	1	P1-14																																																																																																																							
S-P	PT-S, PR-S	31	Mode switching. OFF: Speed; ON: Position																																																																																																																						
S-T	S-T	31	Mode switching. OFF: Speed; ON: Torque																																																																																																																						
T-P	PT-T, PR-T	31	Mode switching. OFF: Torque; ON: Position																																																																																																																						
PT-PR	PT, PR	-	When selecting PT-PR mode or the multi-mode, PT-PR-S, users can select the source via this DI. When this DI is OFF, it is in PT mode. When this DI is ON, it is in PR mode.																																																																																																																						

DI Signal Name	Operation Mode	Pin No.	Function	Wiring Method (Refer to 3.4.3)
EMGS	ALL	30	It is contact <b>B</b> and has to be ON frequently; otherwise the alarm (ALRM) will occur.	C9/C10/C11/C12
NL(CWL)	PT, PR, S, T, Sz, Tz	32	Reverse inhibit limit (contact <b>B</b> ) and has to be ON frequently; or the alarm (ALRM) will occur.	
PL (CCWL)	PT, PR, S, T, Sz, Tz	31	Forward inhibit limit (contact <b>B</b> ) and has to be ON frequently; or the alarm (ALRM) will occur.	
ORGP	PR	-	When DI is ON, the drive will start homing.	
SHOM	PR	-	In PR mode, it needs to search the origin. When this DI is ON, the origin searching function is activated. (Please refer to the setting of parameter P1-47.)	
CAM	PR	-	E-cam engaging control (please refer to the setting of value U and Z of P5-88.)	
JOGU	ALL	-	When this DI is ON, the motor JOG operates in forward direction.	
JOGD	ALL	-	When this DI is ON, the motor JOG operates in reverse direction.	
EV1	PR	-	Event trigger PR command	
EV2	PR	-	Event trigger PR command	
EV3	PR	-	Event trigger PR command	
EV4	PR	-	Event trigger PR command	
GNUM0	PT, PR, PT-S, PR-S	-	Electronic gear ratio (numerator) selection 0 (Please refer to P2-60~P2-62 for gear ratio selection (numerator).)	
GNUM1	PT, PR, PT-S, PR-S	-	Electronic gear ratio (numerator) selection 1 (Please refer to P2-60~P2-62 for gear ratio selection (numerator).)	
INHP	PT, PT-S	-	In position mode, when this DI is ON, the external pulse input command is not working.	

The default setting of DI and DO in each operation mode is shown as the followings. Please note that the following table neither detail the information as the previous one nor show the Pin number of each signal. However, each operation mode is separated in different columns in order to avoid the confusion.

Table 3.1 Default Value of DI Input Function

Symbol	DI Code	Input Function	PT	PR	S	T	Sz	Tz	PT-S	PT-T	PR-S	PR-T	S-T
SON	0x01	Servo On	DI1	DI1	DI1	DI1	DI1	DI1	DI1	DI1	DI1	DI1	DI1
ARST	0x02	Alarm Reset	DI5	DI5	DI5	DI5	DI5	DI5					
GAINUP	0x03	Gain switch											
CCLR	0x04	Pulse clear	DI2						DI2	DI2			
ZCLAMP	0x05	Zero speed CLAMP											
CMDINV	0x06	The input command will be in reverse direction.											
Reserved	0x07	Reserved											
CTRG	0x08	Internal position command triggered		DI2							DI2	DI2	
TRQLM	0x09	Torque limit			DI2		DI2						
SPDLM	0x10	Speed limit				DI2		DI2					
POS0	0x11	Internal position command selection 0		DI3							DI3	DI3	
POS1	0x12	Internal position command selection 1		DI4							DI4	DI4	
POS2	0x13	Internal position command selection 2											
POS3	0x1A	Internal position command selection 3											
POS4	0x1B	Internal position command selection 4											
POS5	0x1C	Internal position command selection 5											
STOP	0x46	Motor stops											
SPD0	0x14	Speed command selection 0			DI3		DI3		DI3		DI5		DI3
SPD1	0x15	Speed command selection 1			DI4		DI4		DI4		DI6		DI4
TCM0	0x16	Torque command selection 0	DI3			DI3		DI3		DI3		DI5	DI5
TCM1	0x17	Torque command selection 1	DI4			DI4		DI4		DI4		DI6	DI6
S-P	0x18	Mode switch between speed and position command							DI7		DI7		
S-T	0x19	Mode switch between speed and torque command											DI7
T-P	0x20	Mode switch between								DI7		DI7	

Symbol	DI Code	Input Function	PT	PR	S	T	Sz	Tz	PT-S	PT-T	PR-S	PR-T	S-T
		torque and position command											
PT-PR	0x2B	Switch between PT and PR command											
EMGS	0x21	Emergency stop	DI8	DI8	DI8	DI8	DI8	DI8	DI8	DI8	DI8	DI8	DI8
NL(CWL)	0x22	Reverse inhibit limit	DI6	DI6	DI6	DI6	DI6	DI6					
PL(CCWL)	0x23	Forward inhibit limit	DI7	DI7	DI7	DI7	DI7	DI7					
ORGP	0x24	Original point of homing											
SHOM	0x27	Homing is activated											
CAM	0x36	E-Cam engaged											
JOGU	0x37	Forward JOG input											
JOGD	0x38	Reverse JOG input											
EV1	0x39	Event trigger PR command #1(refer to the setting of P5-98, P5-99)											
EV2	0x3A	Event trigger PR command #2 (refer to the setting of P5-98, P5-99)											
EV3	0x3B	Event trigger PR command #3 firmware V1.008 sub04 will be provided afterwards)											
EV4	0x3C	Event trigger PR command #4 (firmware V1.008 sub04 will be provided afterwards)											
GNUM0	0x43	Electronic gear ratio (numerator) selection 0											
GNUM1	0x44	Electronic gear ratio (numerator) selection 1											
INHP	0x45	Pulse input inhibit											

**NOTE**

Please refer to Section 3.4.1 for corresponding pin from DI1 ~ 8.

**Table 3.2 Default Value of DO Output Function**

Symbol	DO Code	Output Function	PT	PR	S	T	Sz	Tz	PT-S	PT-T	PR-S	PR-T	S-T
SRDY	0x01	Servo is ready	DO1	DO1	DO1	DO1	DO1	DO1	DO1	DO1	DO1	DO1	DO1
SON	0x02	Servo is On.											
ZSPD	0x03	Zero-speed reached	DO2	DO2	DO2	DO2	DO2	DO2	DO2	DO2	DO2	DO2	DO2
TSPD	0x04	Reach the target speed			DO3	DO3	DO3	DO3	DO3	DO3	DO3	DO3	DO3
TPOS	0x05	Reach the target position	DO4	DO4					DO4	DO4	DO4	DO4	DO4
TQL	0x06	Torque limit											
ALRM	0x07	Servo alarm	DO5	DO5	DO5	DO5	DO5	DO5	DO5	DO5	DO5	DO5	DO5
BRKR	0x08	Brake			DO4	DO4	DO4	DO4					
HOME	0x09	Homing complete	DO3	DO3									
OLW	0x10	Early warning for overload											
WARN	0x11	Servo warning											
OVF	0x12	Position command /feedback overflows											
SNL (SCWL)	0x13	Reverse software limit											
SPL (SCCWL)	0x14	Forward software limit											
Cmd_OK	0x15	Internal position command is completed											
CAP_OK	0x16	Capture procedure is completed											
MC_OK	0x17	Servo procedure is completed											
CAM_AREA	0x18	Master position area of E-CAM											
SP_OK	0x19	Target speed reached											
SDO_0	0x30	Output the status of bit00 of P4-06											
SDO_1	0x31	Output the status of bit01 of P4-06											
SDO_2	0x32	Output the status of bit02 of P4-06											
SDO_3	0x33	Output the status of bit03 of P4-06											
SDO_4	0x34	Output the status of bit04 of P4-06											

Symbol	DO Code	Output Function	PT	PR	S	T	Sz	Tz	PT-S	PT-T	PR-S	PR-T	S-T
SDO_5	0x35	Output the status of bit05 of P4-06											
SDO_6	0x36	Output the status of bit06 of P4-06											
SDO_7	0x37	Output the status of bit07 of P4-06											
SDO_8	0x38	Output the status of bit08 of P4-06											
SDO_9	0x39	Output the status of bit09 of P4-06											
SDO_A	0x3A	Output the status of bit10 of P4-06											
SDO_B	0x3B	Output the status of bit11 of P4-06											
SDO_C	0x3C	Output the status of bit12 of P4-06											
SDO_D	0x3D	Output the status of bit13 of P4-06											
SDO_E	0x3E	Output the status of bit14 of P4-06											
SDO_F	0x3F	Output the status of bit15 of P4-06											

**NOTE**

Please refer to Section 3.4.1 for corresponding pin from DO1 to 5.



### 3.4.3 Wiring Diagrams (CN1)

The valid voltage of speed analog command and torque analog command is between -10V and +10V. The command value can be set via relevant parameters. The input impedance is 10KΩ.

**C1: Speed, Input of Torque Analog Command**

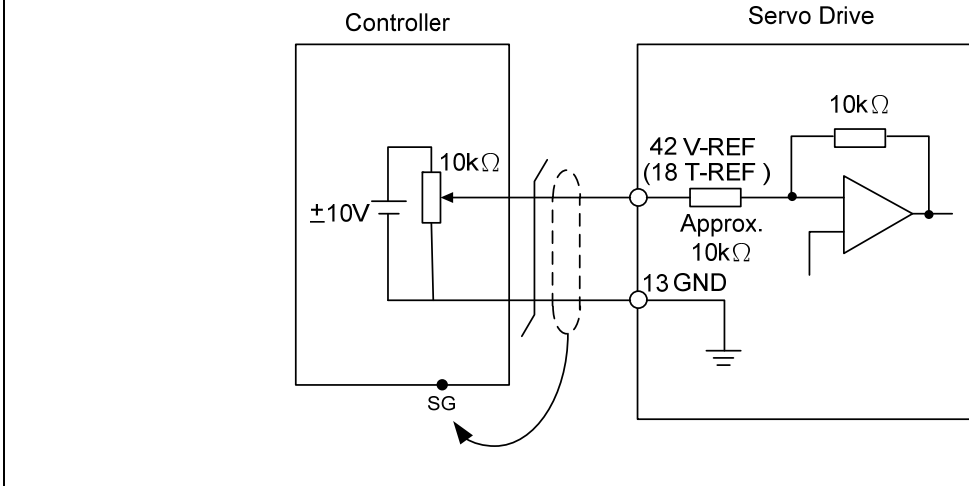

**C2: Analog Monitor Output MON1 ,MON2**

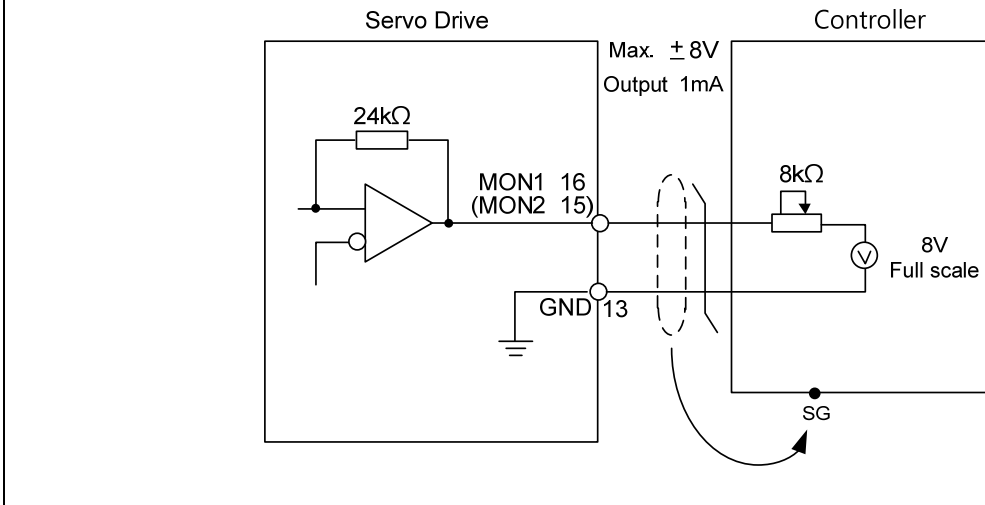

Pulse command can be input by the way of open-collector or Line driver. The maximum input pulse of Line driver is 500 kpps and 200 kpps for open-collector.

C3-1: The source of pulse input is open-collector NPN equipment which applies the internal power of the servo drive.

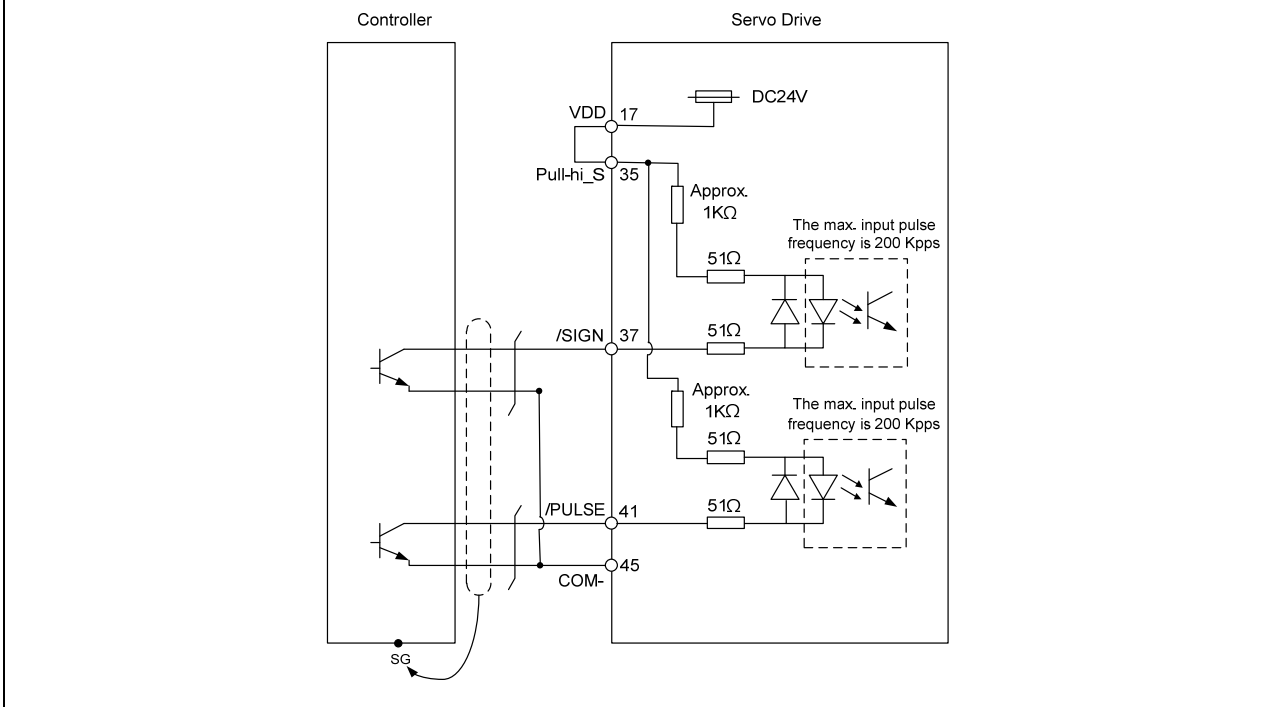

C3-2: The source of pulse input is open-collector PNP equipment which applies the internal power of the servo drive.

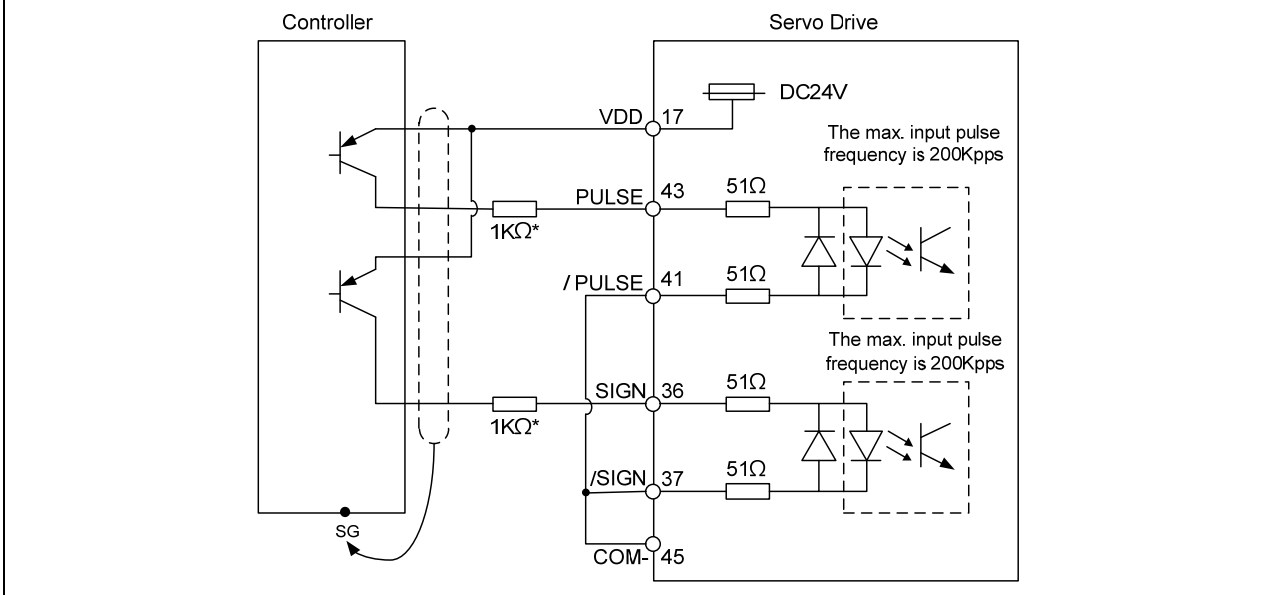

**NOTE** Resistor of 1KΩ(1w) has to be connected.



➤ **Caution: Do not apply to dual power or it may damage the servo drive.**

C3-3: The source of pulse input is open-collector NPN equipment and applies the external power.

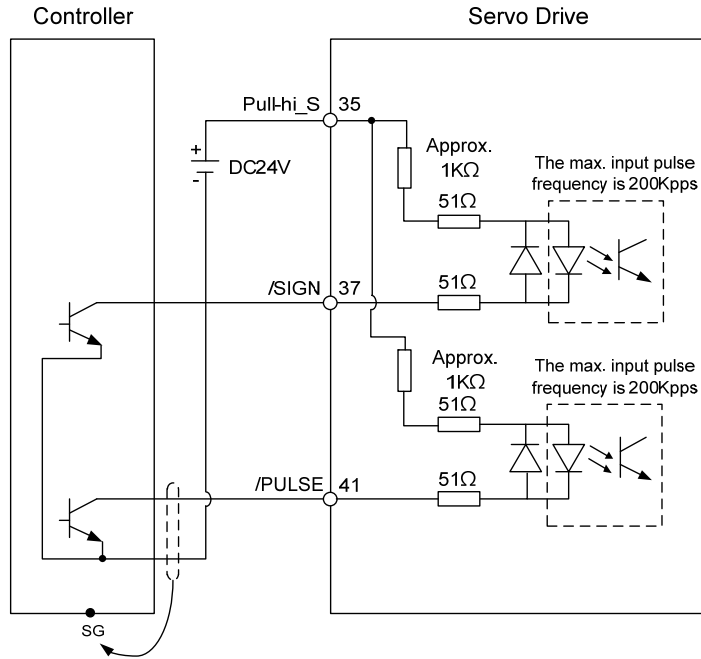

➤ **Caution: Do not apply to dual power or it may damage the servo drive.**

C3-4: The source of pulse input is open-collector PNP equipment and applies the external power.

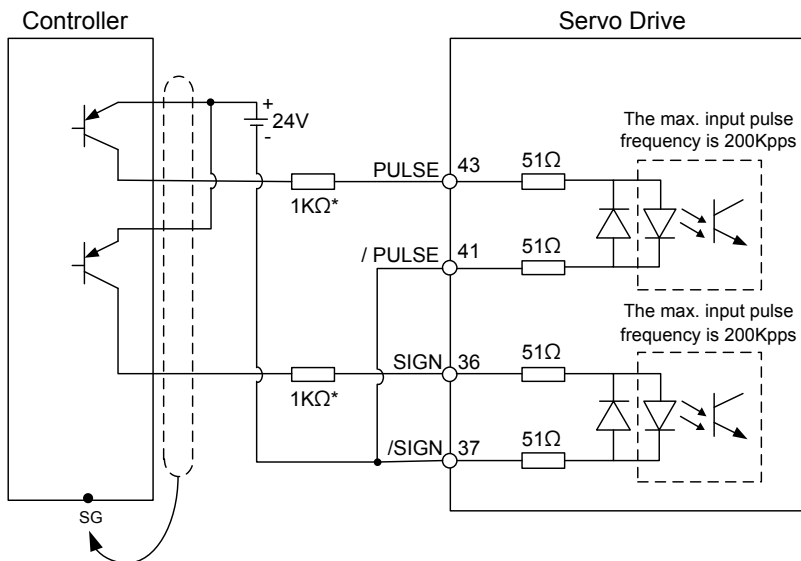

**NOTE** Resistor of 1KΩ(1w) has to be connected.

C4-1: Pulse input (Line driver) can only apply to 5V power. Do not apply to 24V power.

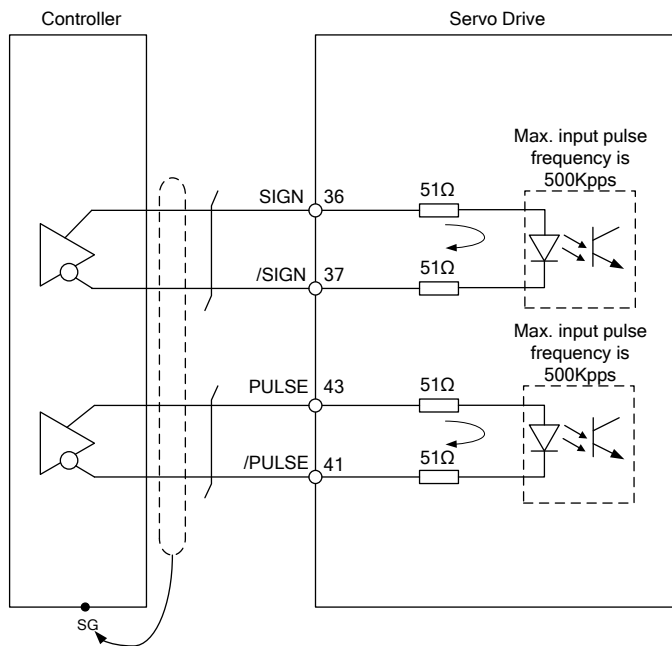

➤ ***This opto-isolator is one-way input, please be ensured the direction of current of pulse input is correct.***

C4-2: High-speed pulse input (Line driver) can only apply to 5V power. Do not apply to 24V power.

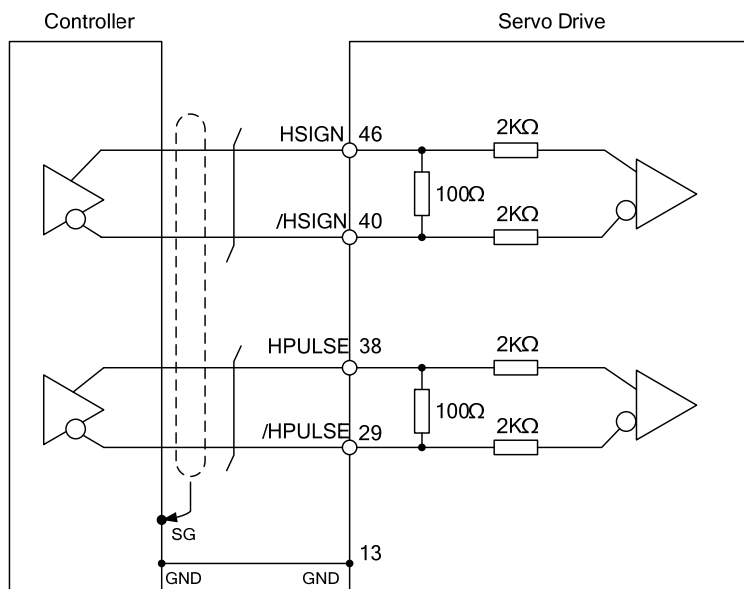

➤ ***The high-speed pulse input interface of the servo drive is not the isolated interface. In order to reduce the interference of the noise, it is suggested that the terminal ground of the controller and the servo drive should be connected to each other.***

When the drive connects to inductive load, the diode has to be installed. (The permissible current is under 40mA. The surge current is under 100mA.)

C5: Wiring of DO signal. The servo drive applies to the internal power and the resistor is general load.

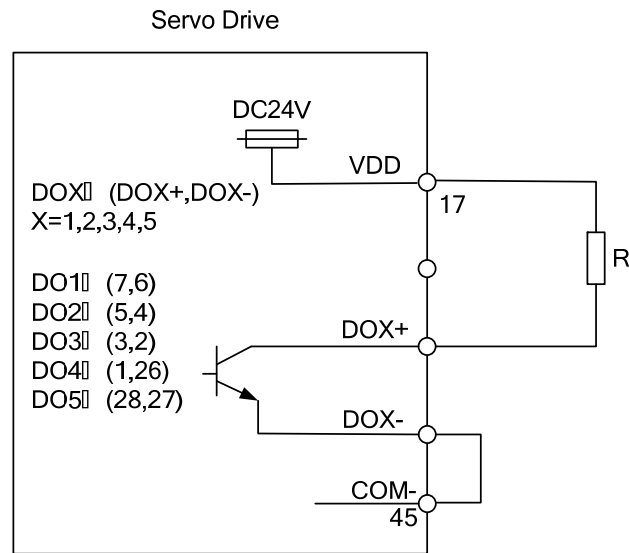

C6: Wiring of DO signal. The servo drive applies to the internal power and the resistor is inductive load.

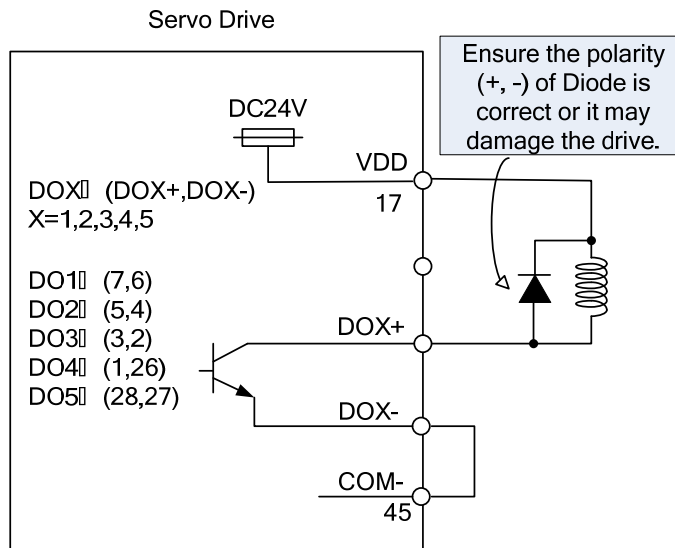

C7: Wiring of DO signal. The servo drive applies to the external power and the resistor is general load.

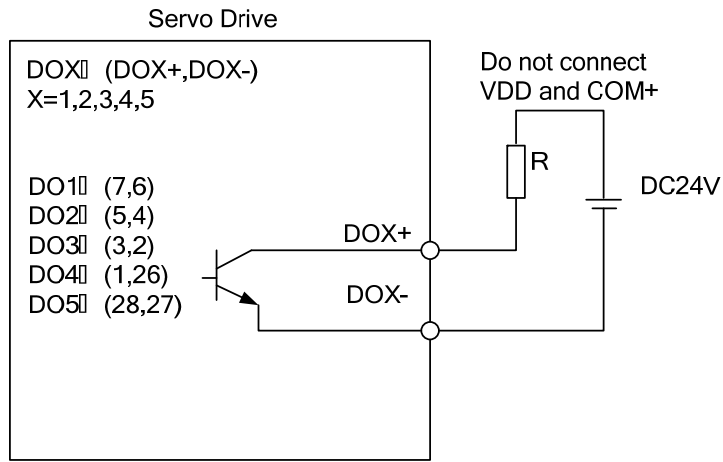

C8: Wiring of DO signal. The servo drive applies to the external power and the resistor is inductive load.

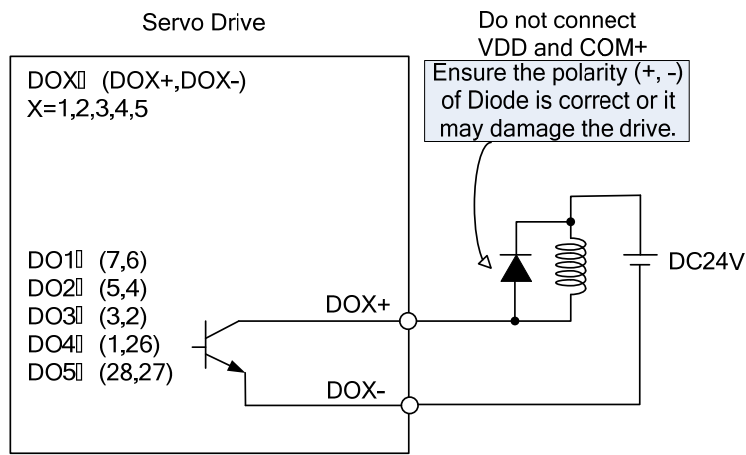

Input signal via relay or open-collector transistor

**NPN transistor, common emitter (E) mode (SINK mode)**

C9: The wiring of DI. The servo drive applies to the internal power.

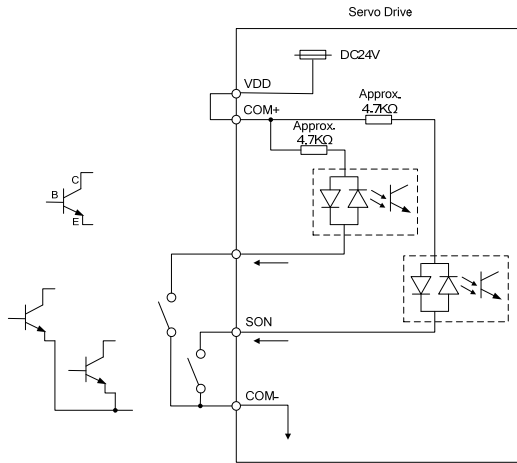

C10: The wiring of DI. The servo drive applies to the external power.

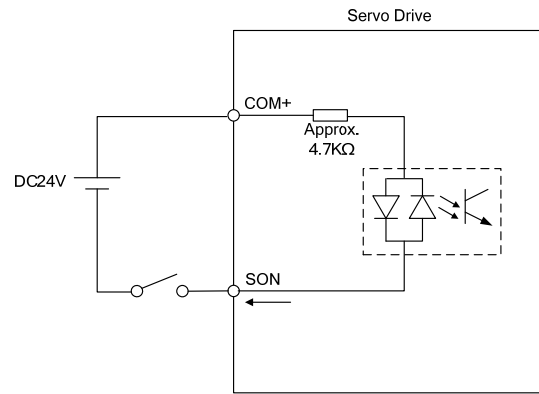

**PNP transistor, common emitter (E) mode (SOURCE mode)**

C11: The wiring of DI. The servo drive applies to the internal power.

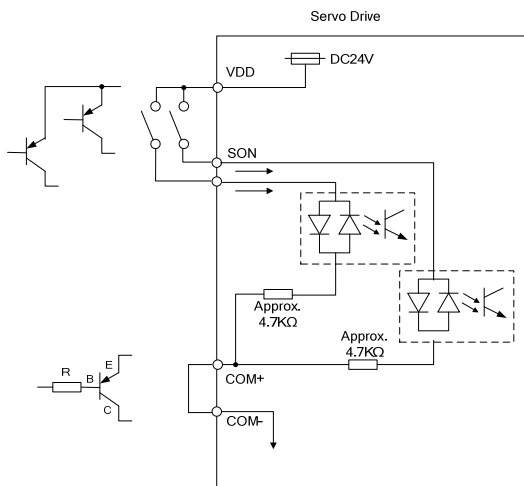

C12: The wiring of DI. The servo drive applies to the external power.

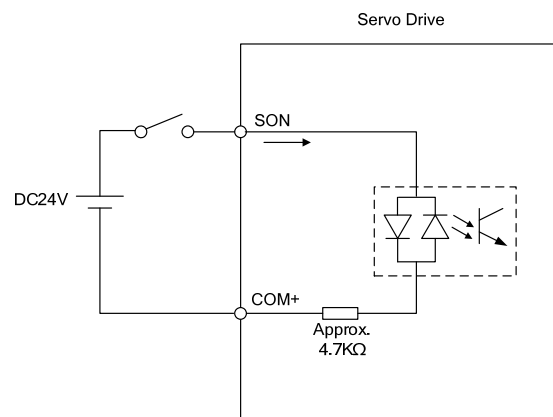

➤ **Caution: Do not apply to dual power or it may damage the servo drive.**

C13: Encoder signal output (Line driver)

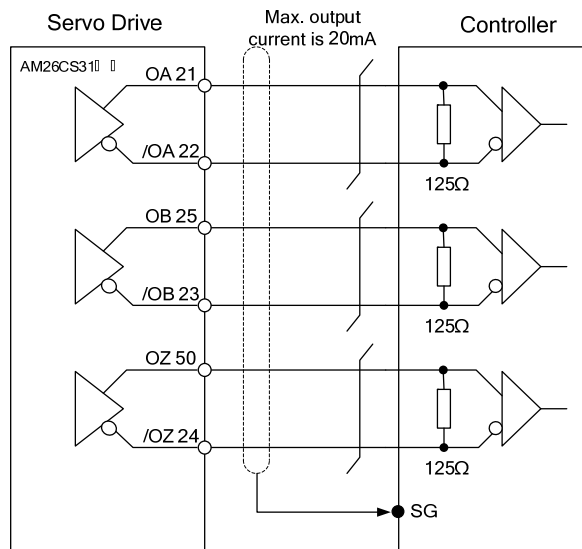

C14: Encoder signal output (Opto-isolator)

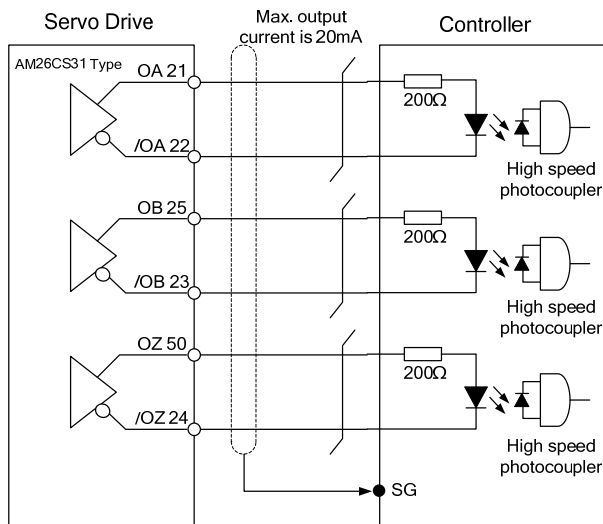

C15: Encoder OCZ output (open-collector Z pulse output)

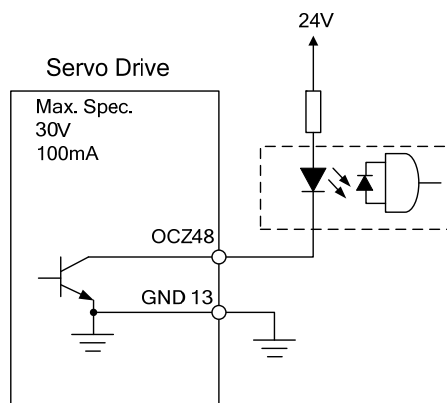



### 3.4.4 DI and DO Signal Specified by Users

If the default setting of DI/DO signal cannot satisfy the need, self-set the DI/DO signal will do and easy. The signal function of DI1 ~ 8, DI9 ~ DI13 and DO1 ~ 5 is determined by parameter P2-10 ~ P2-17 and parameter P2-18 ~ P2-22 respectively. Please refer to Chapter 7.2, which shown as the following table. Enter DI or DO code in the corresponding parameter to setup DI/DO.

Signal Name		Pin No	Corresponding Parameter
Standard DI	DI1-	CN1-9	P2-10
	DI2-	CN1-10	P2-11
	DI3-	CN1-34	P2-12
	DI4-	CN1-8	P2-13
	DI5-	CN1-33	P2-14
	DI6-	CN1-32	P2-15
	DI7-	CN1-31	P2-16
	DI8-	CN1-30	P2-17
Extension DI (optional)	EDI9	CN7-2	P2-36
	EDI10	CN7-3	P2-37
	EDI11	CN7-4	P2-38
	EDI12	CN7-5	P2-39
	EDI13	CN7-6	P2-40
	EDI14	CN7-7	P2-41

Signal Name		Pin No	Corresponding Parameter
Standard DO	DO1+	CN1-7	P2-18
	DO1-	CN1-6	
	DO2+	CN1-5	P2-19
	DO2-	CN1-4	
	DO3+	CN1-3	P2-20
	DO3-	CN1-2	
	DO4+	CN1-1	P2-21
	DO4-	CN1-26	
	DO5+	CN1-28	P2-22
	DO5-	CN1-27	

### 3.4.5 Application: Using CN1 Quick Connector for Wiring

ASD-IF-SC5020 CN1 quick connector is designed for easy wiring. It is applicable to ASDA-A2 and ASDA-A2R series servo drive and can satisfy the demand of different DI/O application. It will be a good choice for those who do not want to self-weld the wiring rods. The vibration will not lose the leading wire due to the design of spring terminal blocks. It is rather convenient and fast when wiring and under construction. 5 digital inputs, 4 digital outputs, pulse command inputs and Z phase open-collector outputs are included.

Pin definition is as the following:

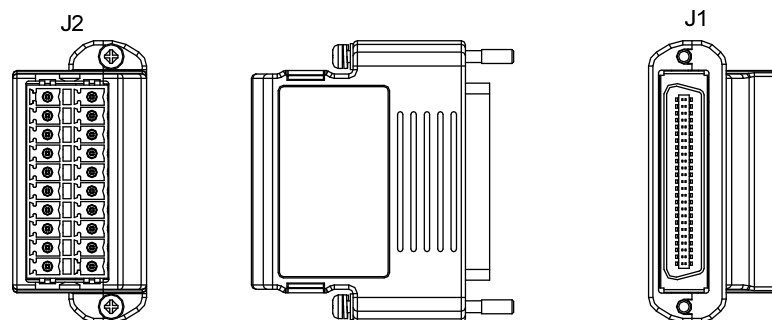

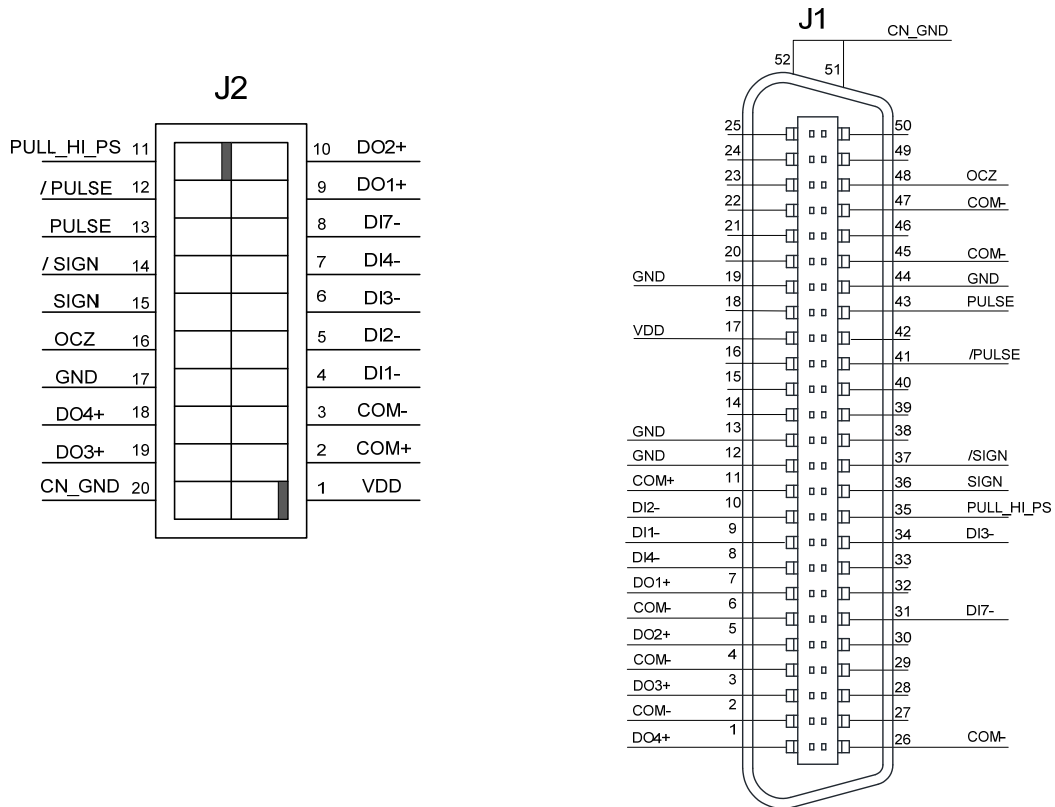

J2		J1	
PIN	Description	PIN	Description
1	VDD	17	VDD
2	COM+	11	COM+
3	COM-	2,4,6,26,45,47	COM-
4	DI1-	9	DI1-
5	DI2-	10	DI2-
6	DI3-	34	DI3-
7	DI4-	8	DI4-
8	DI7-	31	DI7-
9	DO1+	7	DO1+
10	DO2+	5	DO2+
11	PULL_HI_PS	35	PULL_HI_PS
12	/PULSE	41	/PULSE
13	PULSE	43	PULSE
14	/SIGN	37	/SIGN
15	SIGN	36	SIGN
16	OCZ	48	OCZ
17	GND	12,13,19,44	GND

J2		J1	
PIN	Description	PIN	Description
18	DO4+	1	DO4+
19	DO3+	3	DO3+
20	CN_GND	51,52	CN_GND

Example of wiring:

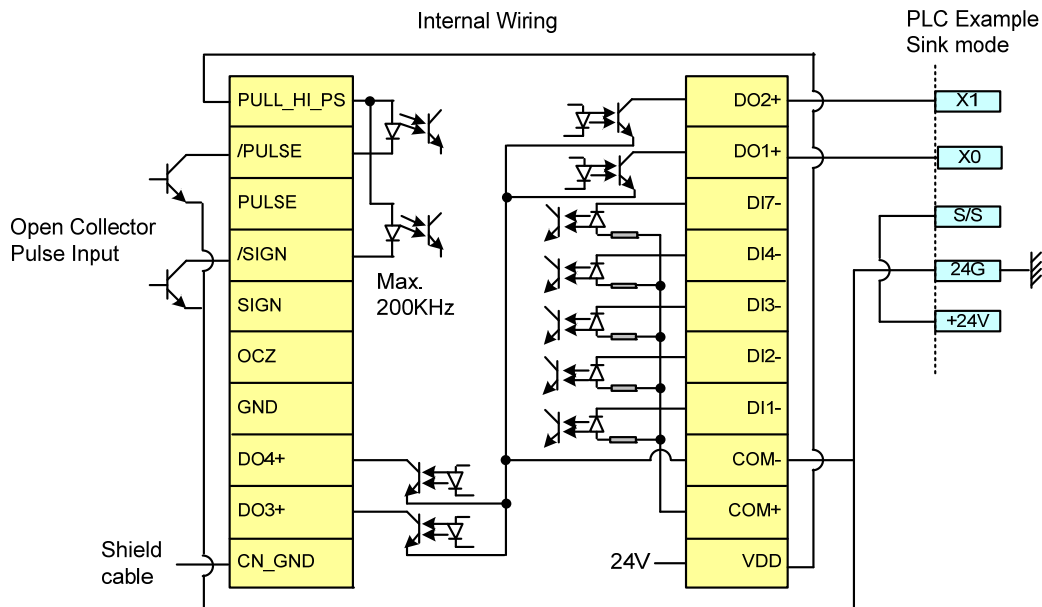
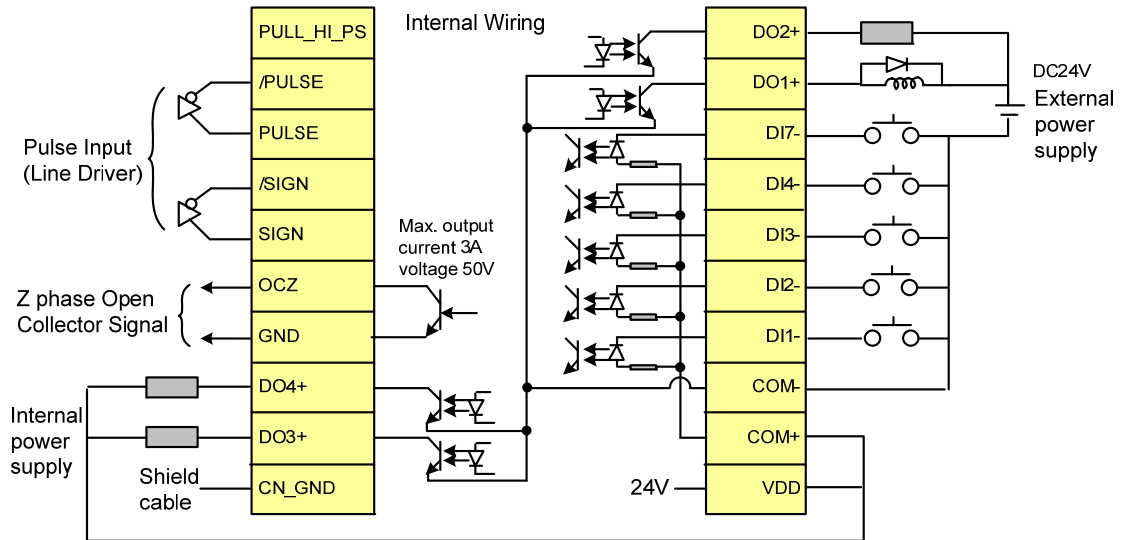

Wiring and installation of CN1 quick connector:

Wiring:

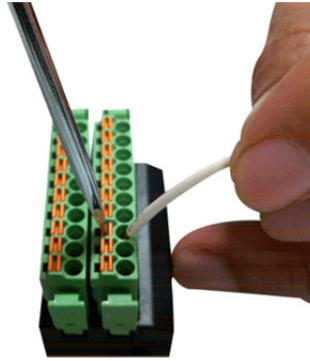

Installation:

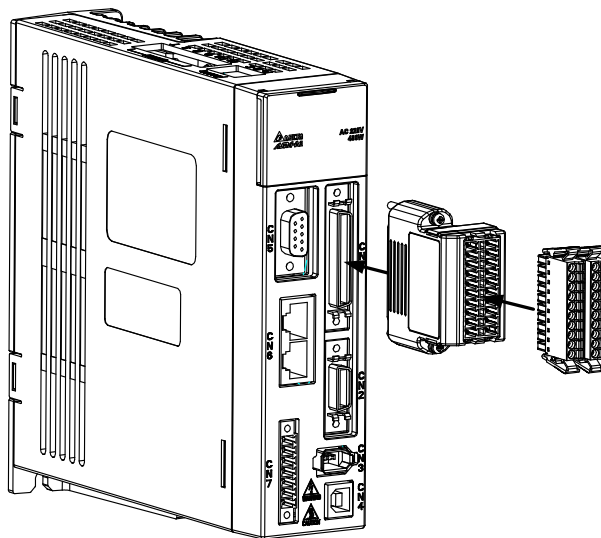

### 3.5 CN2 Connector

The terminal block of the connector and pin number are as follows:

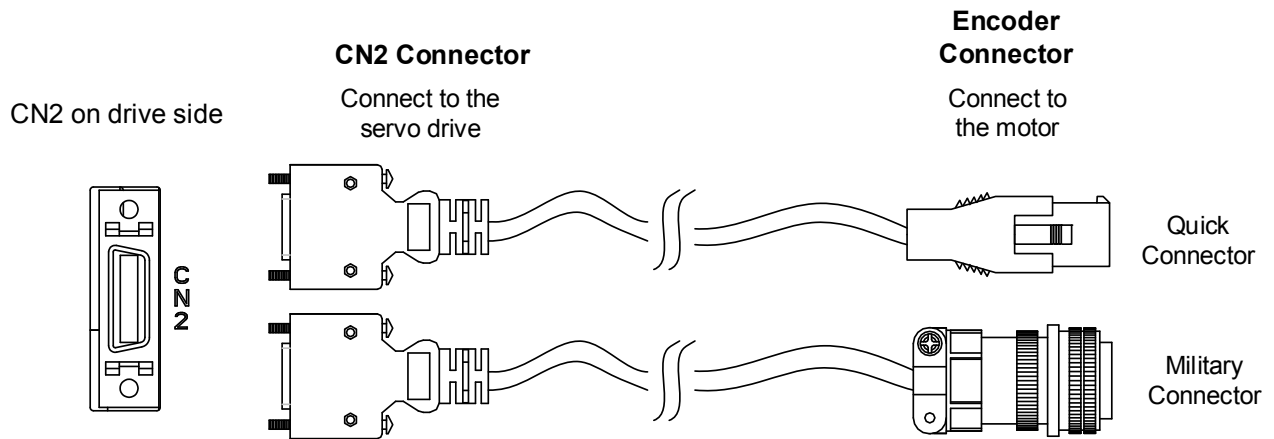

(A) CN2 Connector

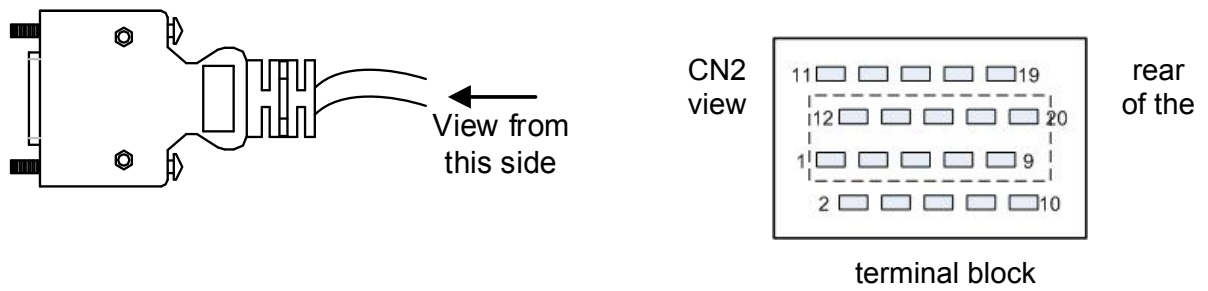

(B) Encoder Connector

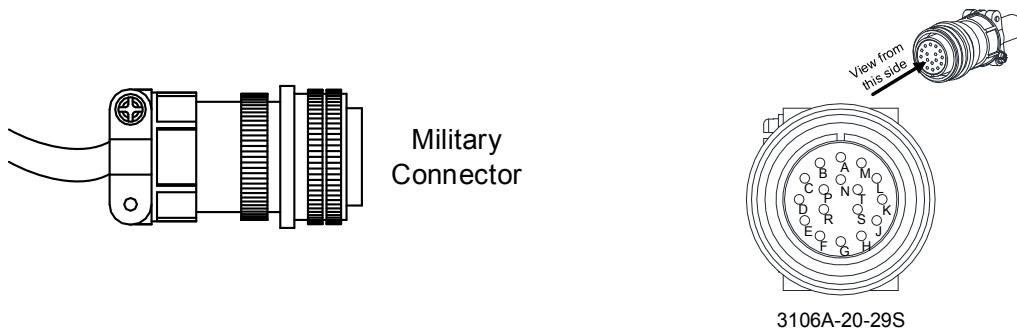
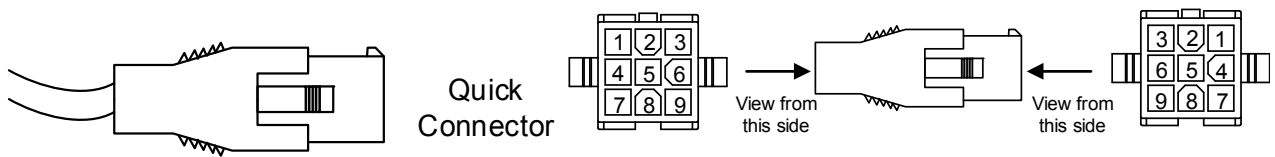

The definition of each signal is as follows:

Drive Connector			Encoder Connector		
PIN No.	Terminal Symbol	Function and Description	Military Connector	Quick Connector	Color
5	T+	Serial communication signal input / output (+)	A	1	Blue
4	T-	Serial communication signal input / output (-)	B	4	Blue & Black
14,16	+5V	+5V power supply	S	7	Red / Red & White
13,15	GND	Power ground	R	8	Black / Black & White
Shell	Shielding-	Shielding	L	9	-

#### About shielding and ground

The both sides of CN2 encoder cable are CN2 connector and encoder connector. Shielding and ground conductor should be correctly connected to the corresponding pins so as to effectively shield and ground.

The shielding procedures of CN2 encoder connector are as followings:



- (1) Cut through the cable and expose the core wire which covers the metal core wires with shielding. The reserved core wire length should be 20~30mm. Then, cover a 45mm heat shrink tube on the cable.

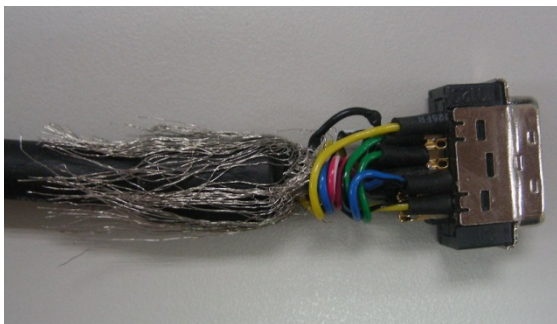

- (2) Spread the metal core wires with shielding and turn it upside down in downward direction. Ensure to follow the above table of CN2 Terminal Signal Identification to connect the pins one by one.

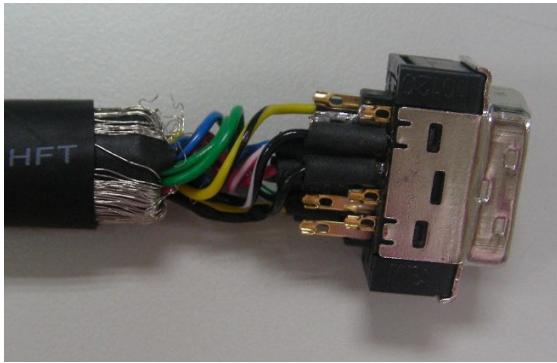

- (3) Leave a length of 5~10mm metal core wires with shielding outside of the cable. The length is about the width of the metal saddle. The other unexposed wires of the cable should be protected by heat shrink tube for good ground contact.

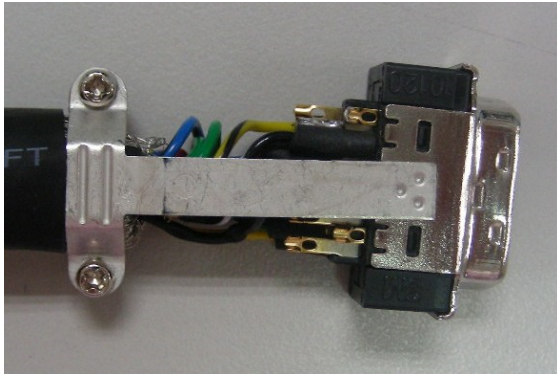

- (4) Install a metal saddle to fix the exposed metal core wires. The metal saddle must completely cover all the exposed metal core wires. The extended sheet metal should be connected to the metal part of the connector.

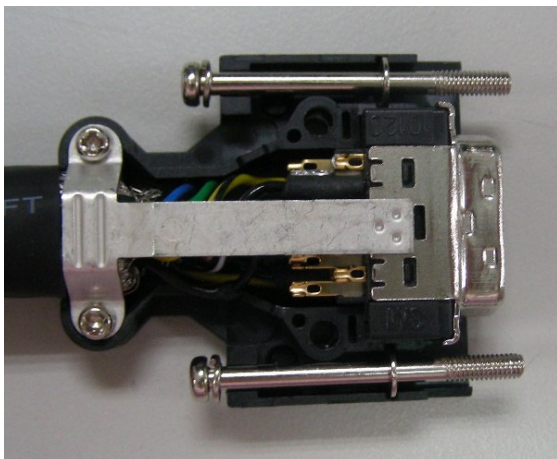

- (5) Install the connector with shielding into the plastic case as shown in the figure.

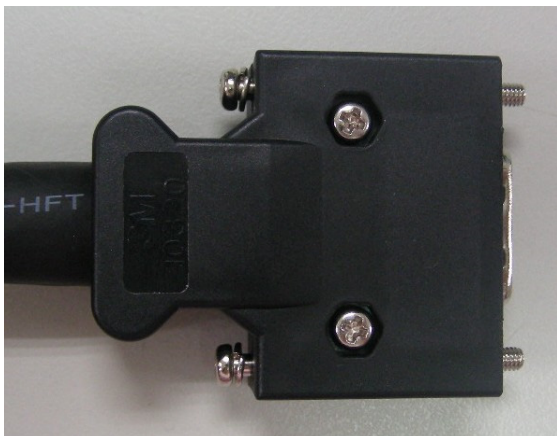

- (6) Tighten the screws to complete a shielded CN2 connector.

## 3.6 Wiring of CN3 Connector

### 3.6.1 Layout of CN3 Connector

The servo drive connects to the personal computer via communication connector. The user can operate the servo drive via MODBUS, PLC or HMI. There are two common communication interfaces, RS-232 and RS-485. Both can be set via parameter P3-05. Among them, RS-232 is more common. Its communication distance is about 15 meter. If the user selects RS-485, its transmission distance is longer and supports more than one servo drives for connection.

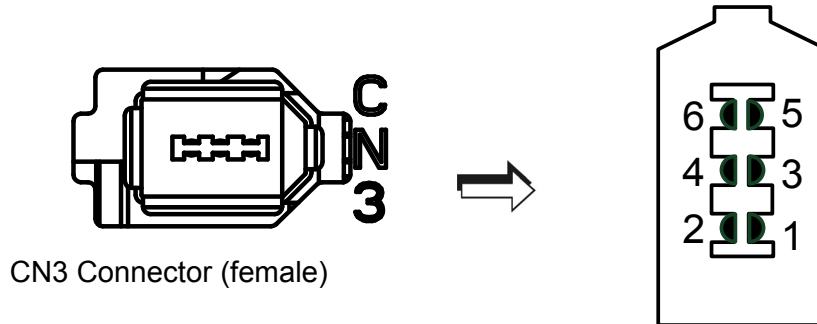

CN3 Connector (female)

PIN No.	Signal Name	Terminal Symbol	Function and Description
1	Grounding	GND	+ 5 V connects to the signal terminal
2	RS-232 data transmission	RS-232_TX	The drive transmits the data The connector connects to RS-232 of PC
3	-	-	Reserved
4	RS-232 data receiving	RS-232_RX	The drive receives the data The connector connects to RS-232 of PC
5	RS-485 data transmission	RS-485(+)	The drive transmits the date to differential terminal (+)
6	RS-485 data transmission	RS-485(-)	The drive transmits the date to differential terminal (-)

#### NOTE

- 1) Please refer to Chapter 9, page 2 for the wiring of RS-485.
- 2) Two kinds of communication wire of IEEE1394 are commercially available. One of the internal ground terminals (Pin 1) will short circuit with the shielding and will damage the drive. Do not connect GND to the shielding.



### 3.6.2 Connection between PC and Connector CN3

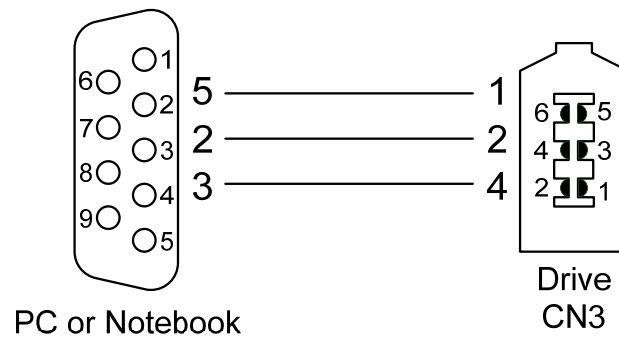

### 3.7 CN4 Serial Connector (USB)

CN4 is a serial connector which used to connect PC software and enhance the efficiency. The transmission speed of USB can up to 1MB, that is to say PC Data Scope can obtain the correct data in time.

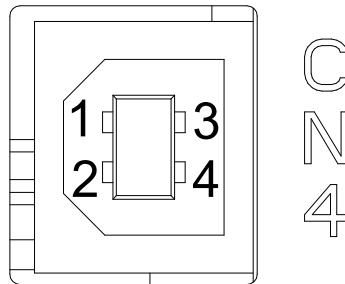

CN4 Connector (female)

PIN No.	Signal Name	Function and Description
1	V bus	DC +5V (external power supply)
2	D-	Data-
3	D+	Data+
4	GND	Ground

### 3.8 CN5 Connector (Full-closed loop)

Connect to the external linear scale or encoder (A, B, Z) and form a full-closed loop with the servo. In position mode, the pulse position command issued by the controller is based on the control loop of the external linear scale. Please refer to Chapter 6.

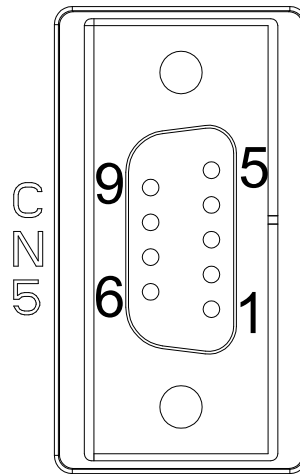

CN5 Connector (female)

Pin No.	Signal Name	Terminal Symbol	Function and Description
1	/Z phase input	Opt_/Z	Linear scale /Z phase output
2	/B phase input	Opt_/B	Linear scale /B phase output
3	B phase input	Opt_B	Linear scale B phase output
4	A phase input	Opt_A	Linear scale A phase output
5	/A phase input	Opt_/A	Linear scale /A phase output
6	Encoder grounding	GND	Ground
7	Encoder grounding	GND	Ground
8	Encoder power	+5V	Linear scale 5V power
9	Z phase input	Opt_Z	Linear scale Z phase output

#### NOTE

- 1) It only supports AB phase signal and the encoder with 5 V.
- 2) Application of full-closed loop: It supports the encoder with highest resolution, 1280000 pulse rev (Full-closed loop corresponds to the resolution of quadruple frequency when motor runs a cycle.).

### 3.9 CN6 Connector (CANopen)

Based on the standard of CANopen DS301 and DS402, CN6 uses the standard CAN interface to implement position, torque and speed mode. It also can read or monitor the drive status.

The station number of CANopen is the same as RS-232/RS-485. All are set via parameter P3-00 and the transmission rate can up to 1 Mbps. It provides two sets of communication connectors, one is for receiving and another one is for transmission, in order to connect more than one drives. The last servo drive connects to termination resistor.

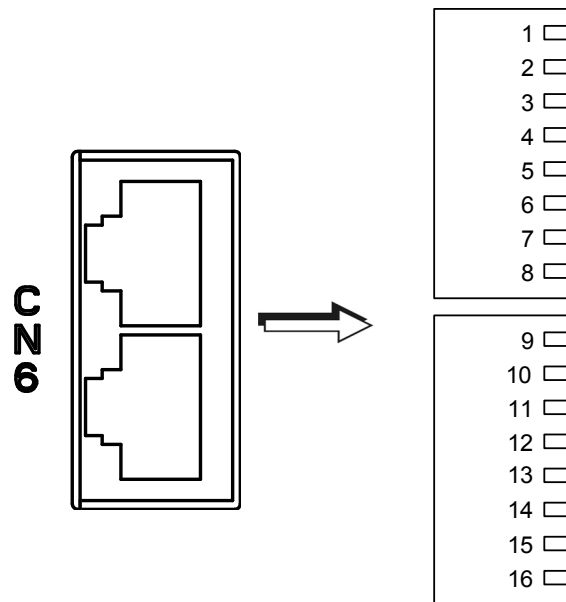

CN6 Connector (female)

PIN No.	Signal Name	Function and Description
1, 9	CAN_H	CAN_H bus line (dominant high)
2, 10	CAN_L	CAN_H bus line (dominant low)
3, 11	CAN_GND	Ground / 0 V / V -
4, 12	-	Reserved
5, 13	-	Reserved
6, 14	-	Reserved
7, 15	CAN_GND	Ground / 0 V / V -
8, 16	-	Reserved

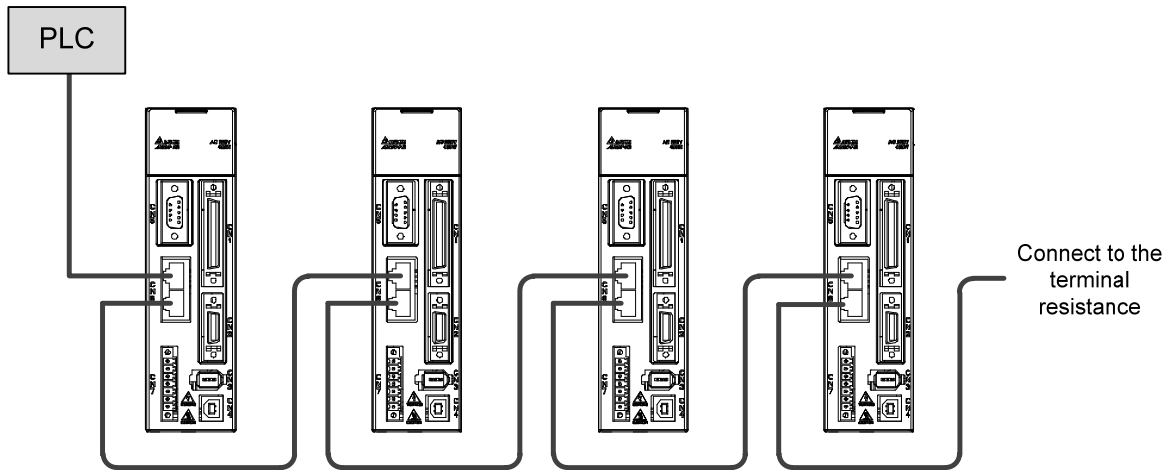

It can support up to 127 axes

**NOTE**

- 1) The termination resistor is suggested to use 120 Ω (Ohm) 0.25W or above.
- 2) The wiring method of concatenate more than one drives is based on two terminals of CANopen. One is for receiving and another one is for transmission. And the servo drive connects to the termination resistor. The wiring diagram of the termination resistor is shown as the followings:

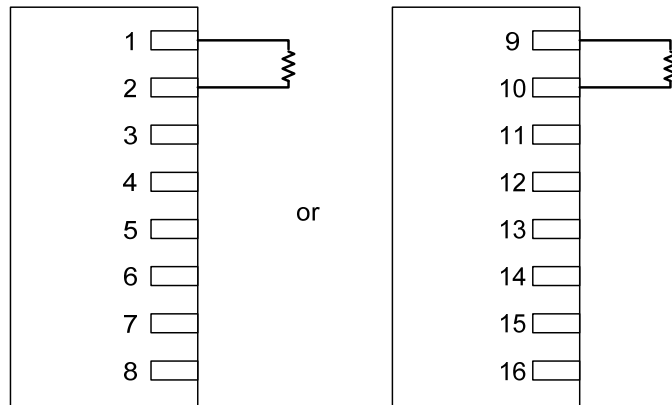

### 3.10 Extension Digital Input Connector of CN7

A2 series servo drive provides additional extension DI on CN7 port. The function of this DI is similar to the one on CN1. Users can define and program it according to the demand.

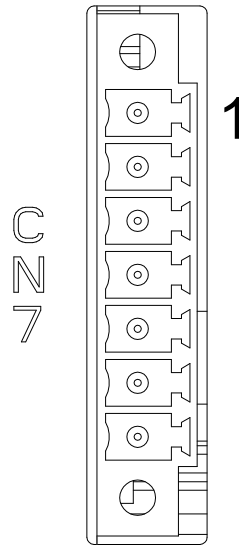

CN7 Connector (female)

PIN No.	Signal Name	Terminal Symbol	Function Description
*1	VDD 24V power	COM+	VDD (24V) power supply, same as Pin 11 of CN1
2	Extension DI9	EDI 9-	Digital input DI9-
3	Extension DI10	EDI 10-	Digital input DI10-
4	Extension DI11	EDI 11-	Digital input DI11-
5	Extension DI12	EDI 12-	Digital input DI12-
6	Extension DI13	EDI 13-	Digital input DI13-
7	Extension DI14	EDI 14-	Digital input DI14-



➤ **\*1 Caution: Do not use dual power supply or it might damage the servo drive.**

### 3.11 CN8 Connector of Battery Box

CN8 connector on servo drive is the power supply for absolute battery box. Please refer to Chapter 12 for further information.

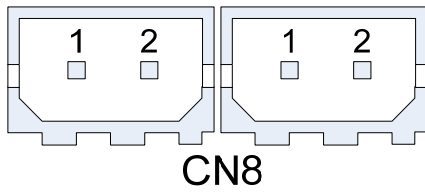

CN8

CN8 Connector of Battery Box

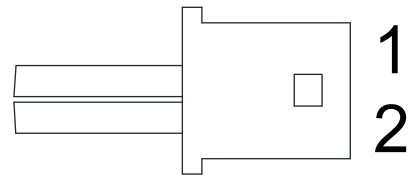

Connector

Pin Definition:

Pin No	Connector1	Connector2
1	BAT+	BAT+
2	BAT-	BAT-



**NOTE**

Due to the different design of servo drive model, CN8 might have one or two connectors, which however has the same pin definition.

### 3.12 Standard Connection Example – 220V series

#### 3.12.1 Position (PT) Control Mode

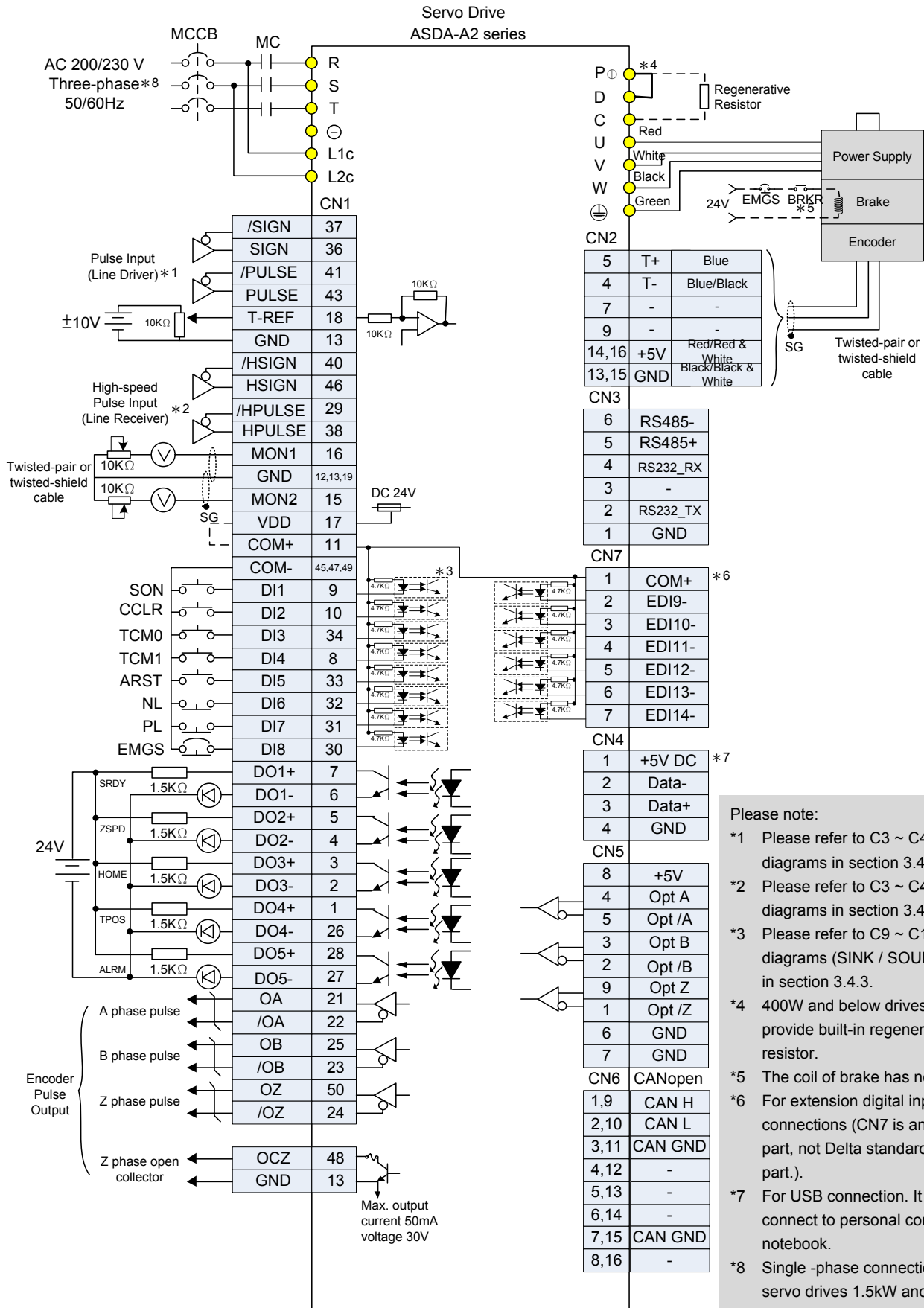



### 3.12.2 Position (PR) Control Mode

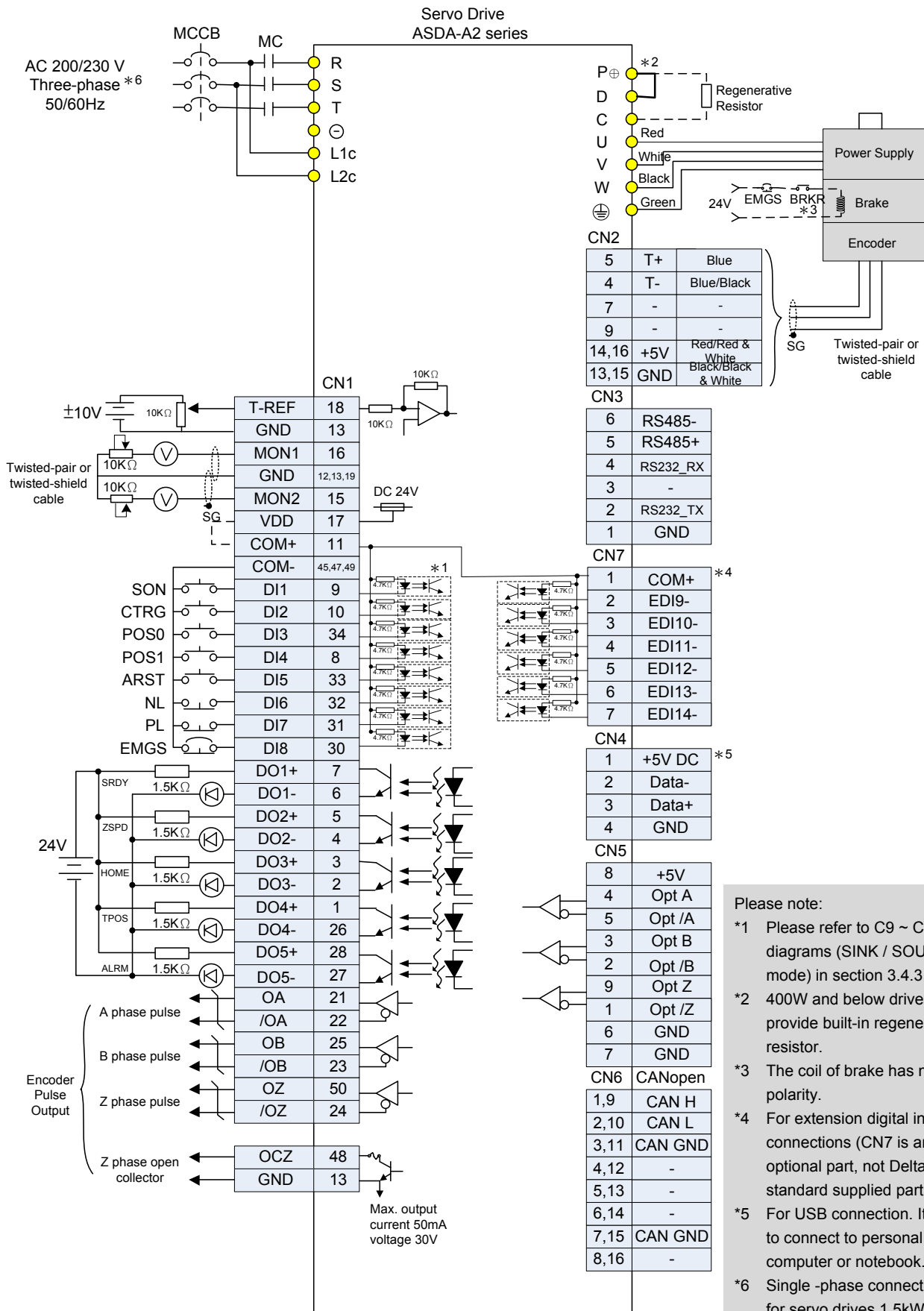

**Please note:**

- \*1 Please refer to C9 ~ C12 wiring diagrams (SINK / SOURCE mode) in section 3.4.3.
- \*2 400W and below drives do not provide built-in regenerative resistor.
- \*3 The coil of brake has no polarity.
- \*4 For extension digital inputs (DI) connections (CN7 is an optional part, not Delta standard supplied part.).
- \*5 For USB connection. It is used to connect to personal computer or notebook.
- \*6 Single -phase connections are for servo drives 1.5kW and below only.

### 3.12.3 Speed Control Mode

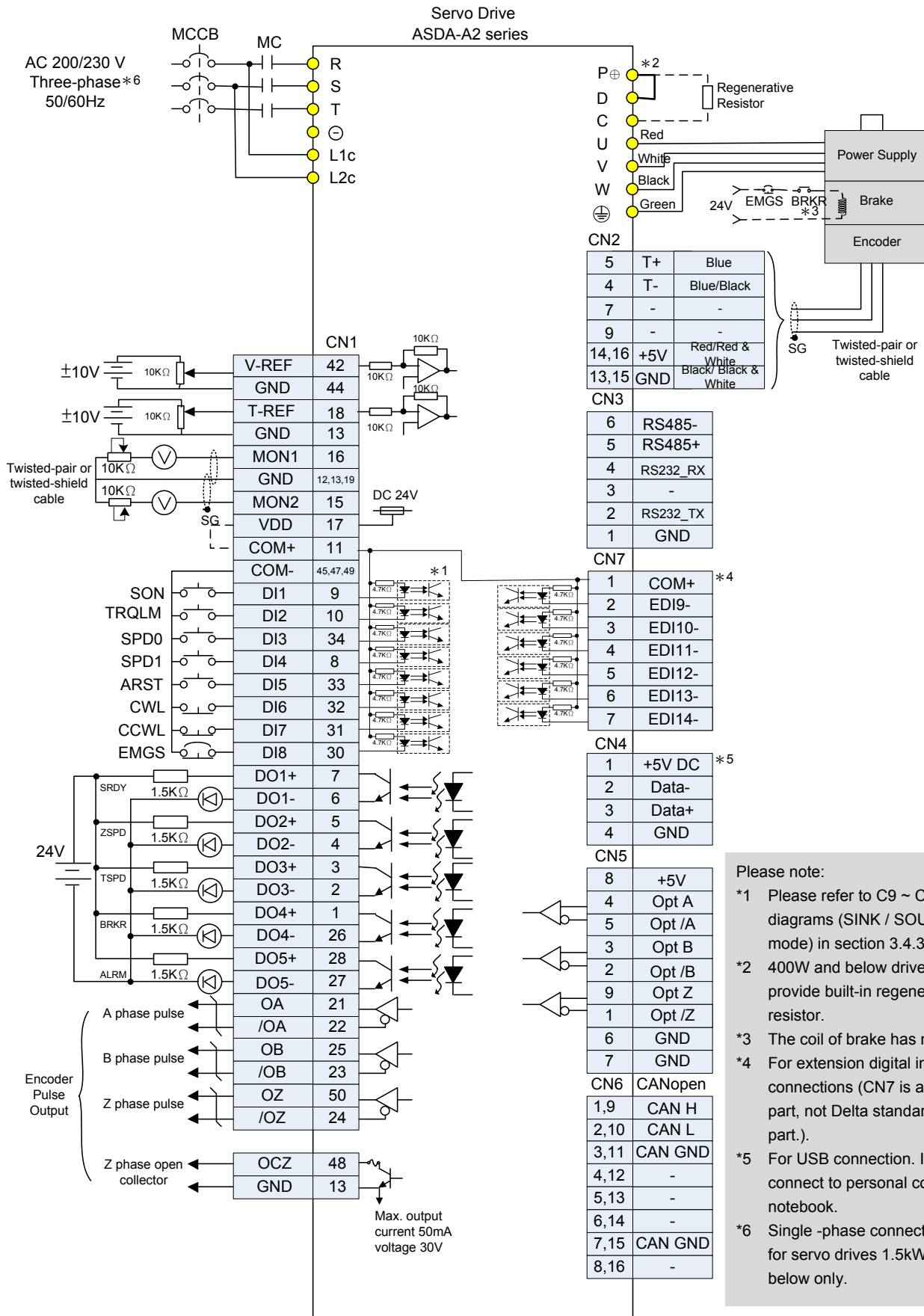

Please note:

- \*1 Please refer to C9 ~ C12 wiring diagrams (SINK / SOURCE mode) in section 3.4.3.
- \*2 400W and below drives do not provide built-in regenerative resistor.
- \*3 The coil of brake has no polarity.
- \*4 For extension digital inputs (DI) connections (CN7 is an optional part, not Delta standard supplied part.).
- \*5 For USB connection. It is used to connect to personal computer or notebook.
- \*6 Single -phase connections are for servo drives 1.5kW and below only.

### 3.12.4 Torque Control Mode

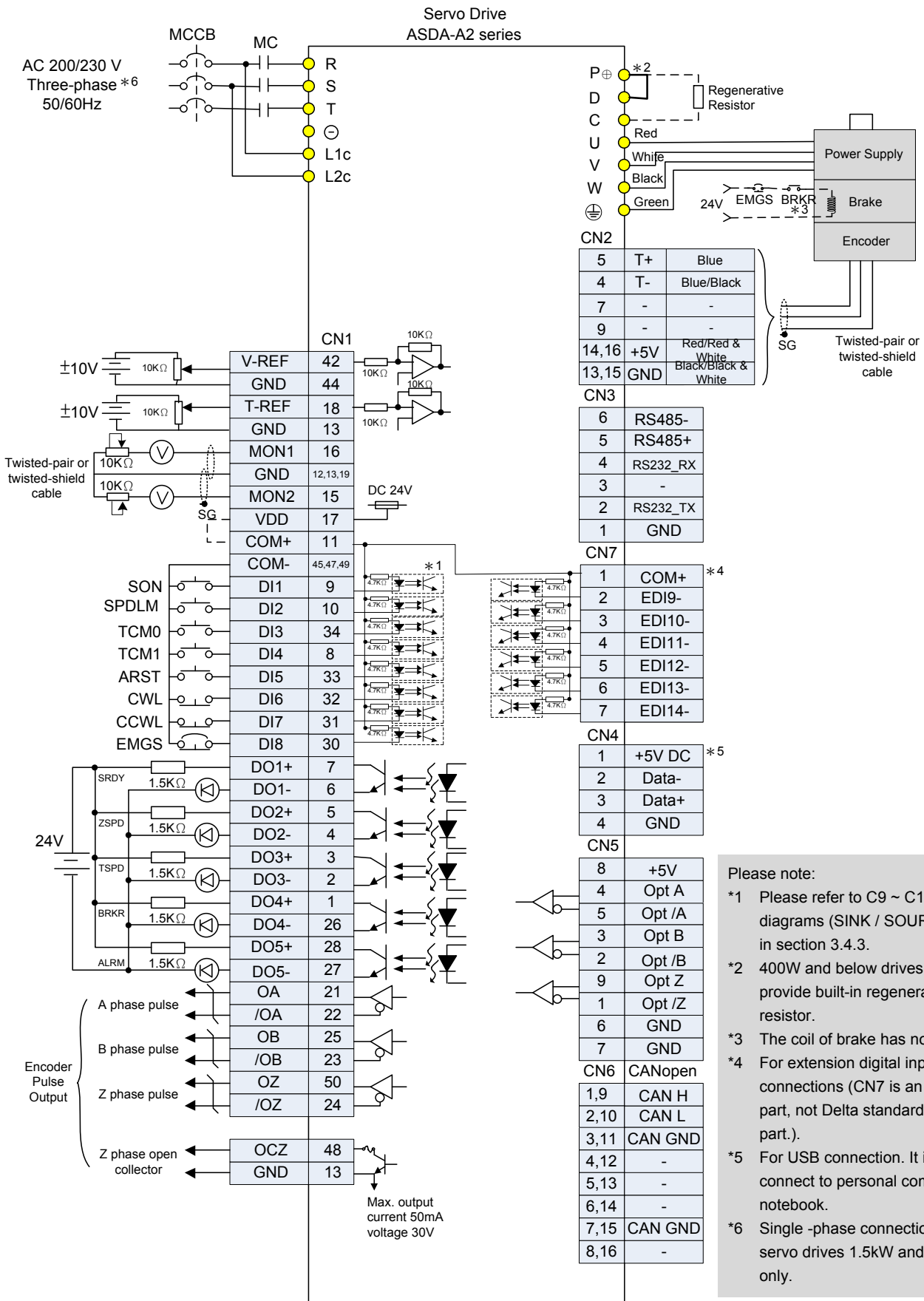

- Please note:
- \*1 Please refer to C9 ~ C12 wiring diagrams (SINK / SOURCE mode) in section 3.4.3.
  - \*2 400W and below drives do not provide built-in regenerative resistor.
  - \*3 The coil of brake has no polarity.
  - \*4 For extension digital inputs (DI) connections (CN7 is an optional part, not Delta standard supplied part.).
  - \*5 For USB connection. It is used to connect to personal computer or notebook.
  - \*6 Single -phase connections are for servo drives 1.5kW and below only.

### 3.12.5 Communication Mode

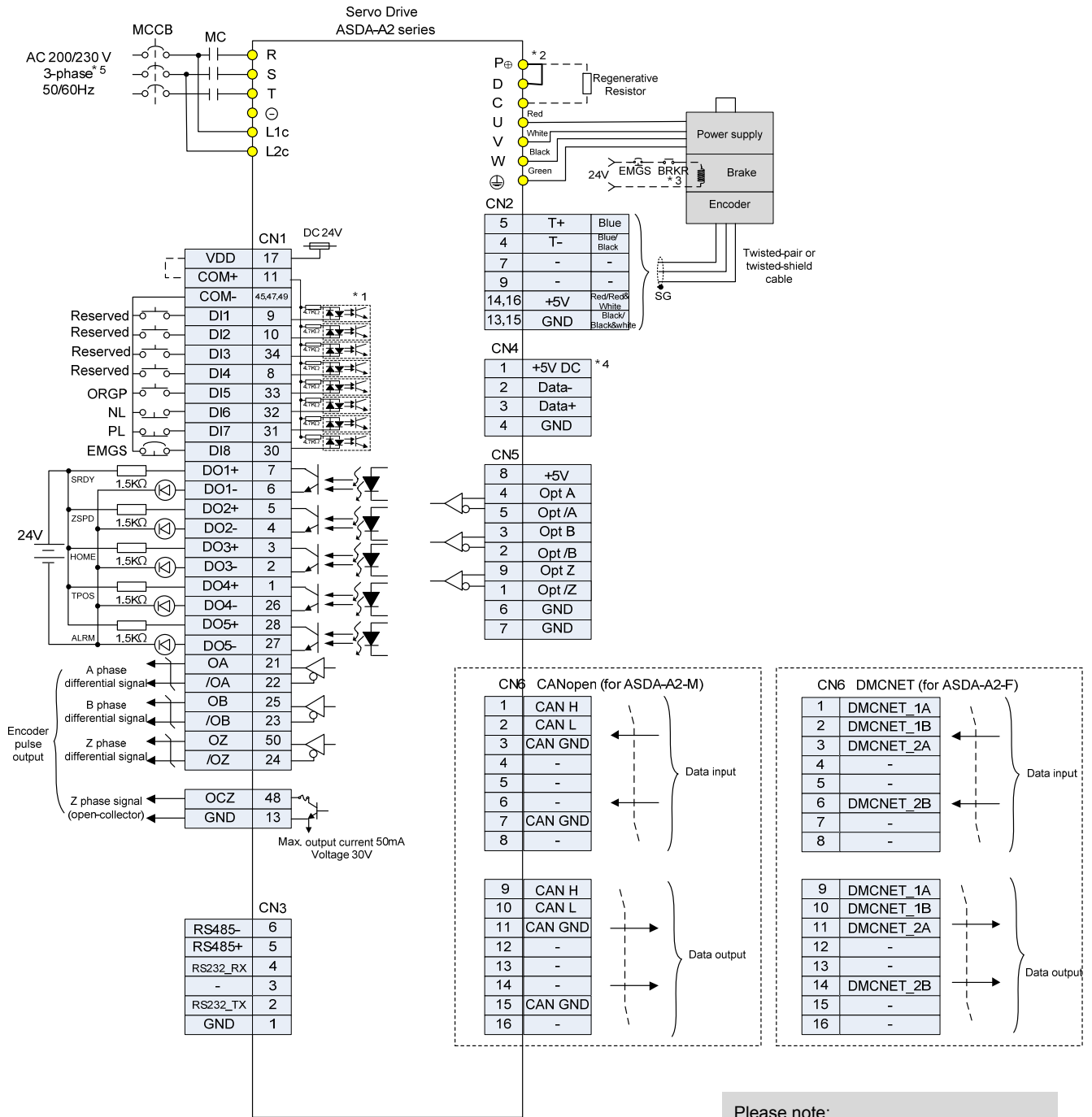

**Please note:**

- \*1 Please refer to C9 ~ C12 wiring diagrams (SINK / SOURCE mode) in section 3.4.4.
- \*2 400W and below drives do not provide built-in regenerative resistor.
- \*3 The coil of brake has no polarity.
- \*4 For USB connection. It is used to connect to personal computer or notebook.
- \*5 Single -phase connections are for servo drives 1.5kW and below only.
- \*6 A2-F only supports DMCNET mode.

### 3.13 Standard Connection Example – 400V series

#### 3.13.1 Position (PT) Control Mode

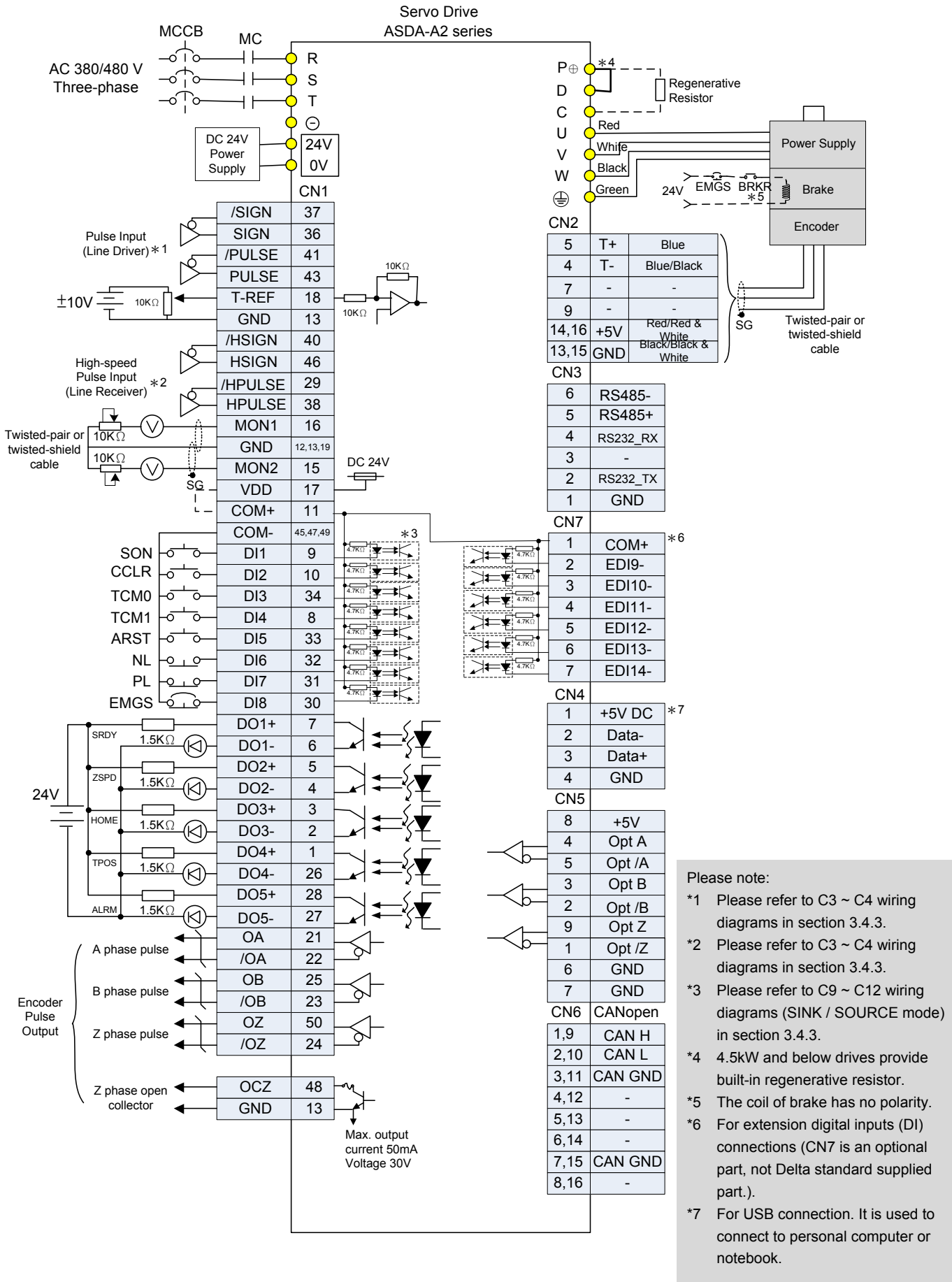

**Please note:**

- \*1 Please refer to C3 ~ C4 wiring diagrams in section 3.4.3.
- \*2 Please refer to C3 ~ C4 wiring diagrams in section 3.4.3.
- \*3 Please refer to C9 ~ C12 wiring diagrams (SINK / SOURCE mode) in section 3.4.3.
- \*4 4.5kW and below drives provide built-in regenerative resistor.
- \*5 The coil of brake has no polarity.
- \*6 For extension digital inputs (DI) connections (CN7 is an optional part, not Delta standard supplied part.).
- \*7 For USB connection. It is used to connect to personal computer or notebook.

### 3.13.2 Position (PR) Control Mode

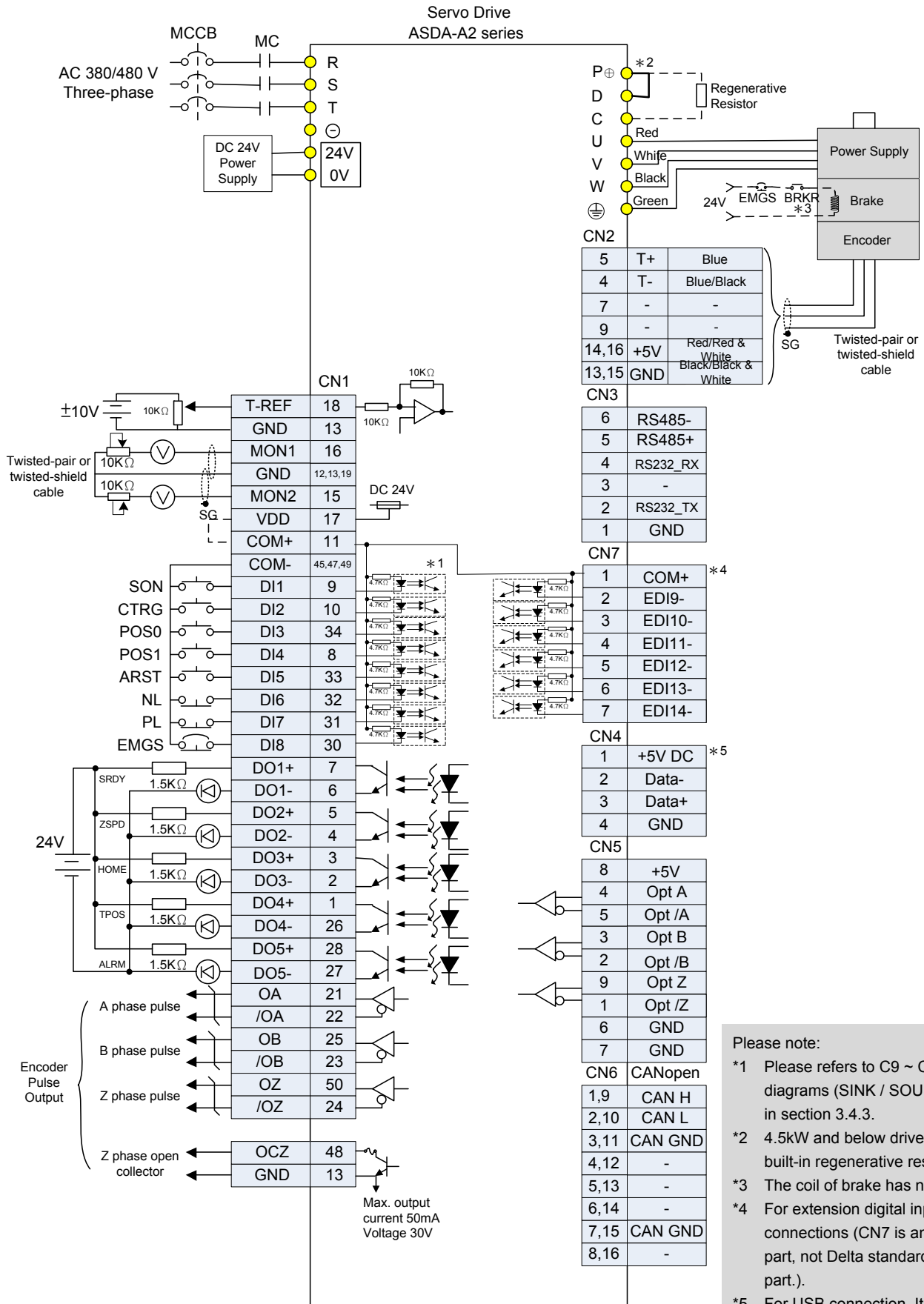

**Please note:**

- \*1 Please refers to C9 ~ C12 wiring diagrams (SINK / SOURCE mode) in section 3.4.3.
- \*2 4.5kW and below drives provide built-in regenerative resistor.
- \*3 The coil of brake has no polarity.
- \*4 For extension digital inputs (DI) connections (CN7 is an optional part, not Delta standard supplied part.).
- \*5 For USB connection. It is used to connect to personal computer or notebook.

### 3.13.3 Speed Control Mode

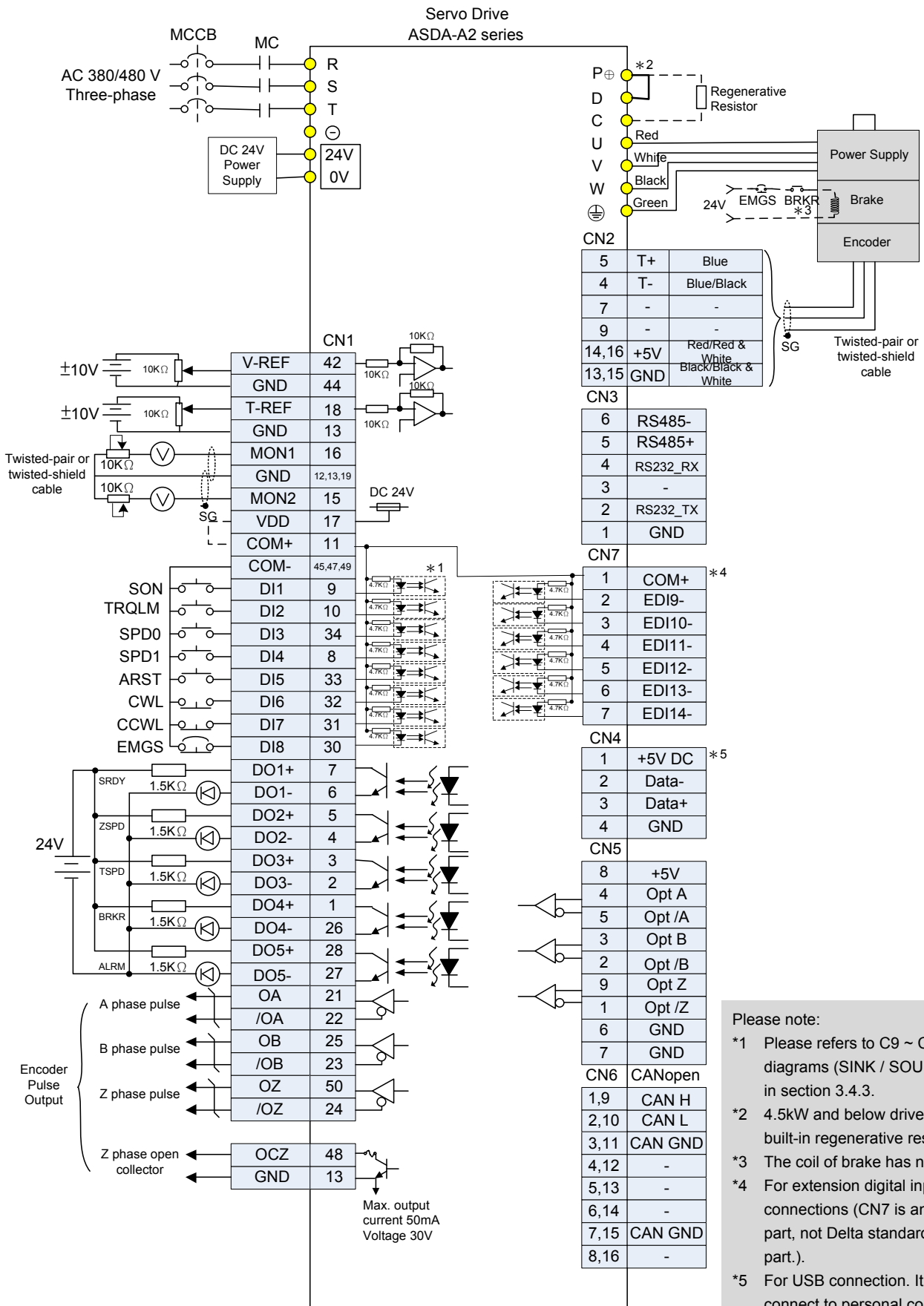

Please note:

- \*1 Please refers to C9 ~ C12 wiring diagrams (SINK / SOURCE mode) in section 3.4.3.
- \*2 4.5kW and below drives provide built-in regenerative resistor.
- \*3 The coil of brake has no polarity.
- \*4 For extension digital inputs (DI) connections (CN7 is an optional part, not Delta standard supplied part.).
- \*5 For USB connection. It is used to connect to personal computer or notebook.

### 3.13.4 Torque Control Mode

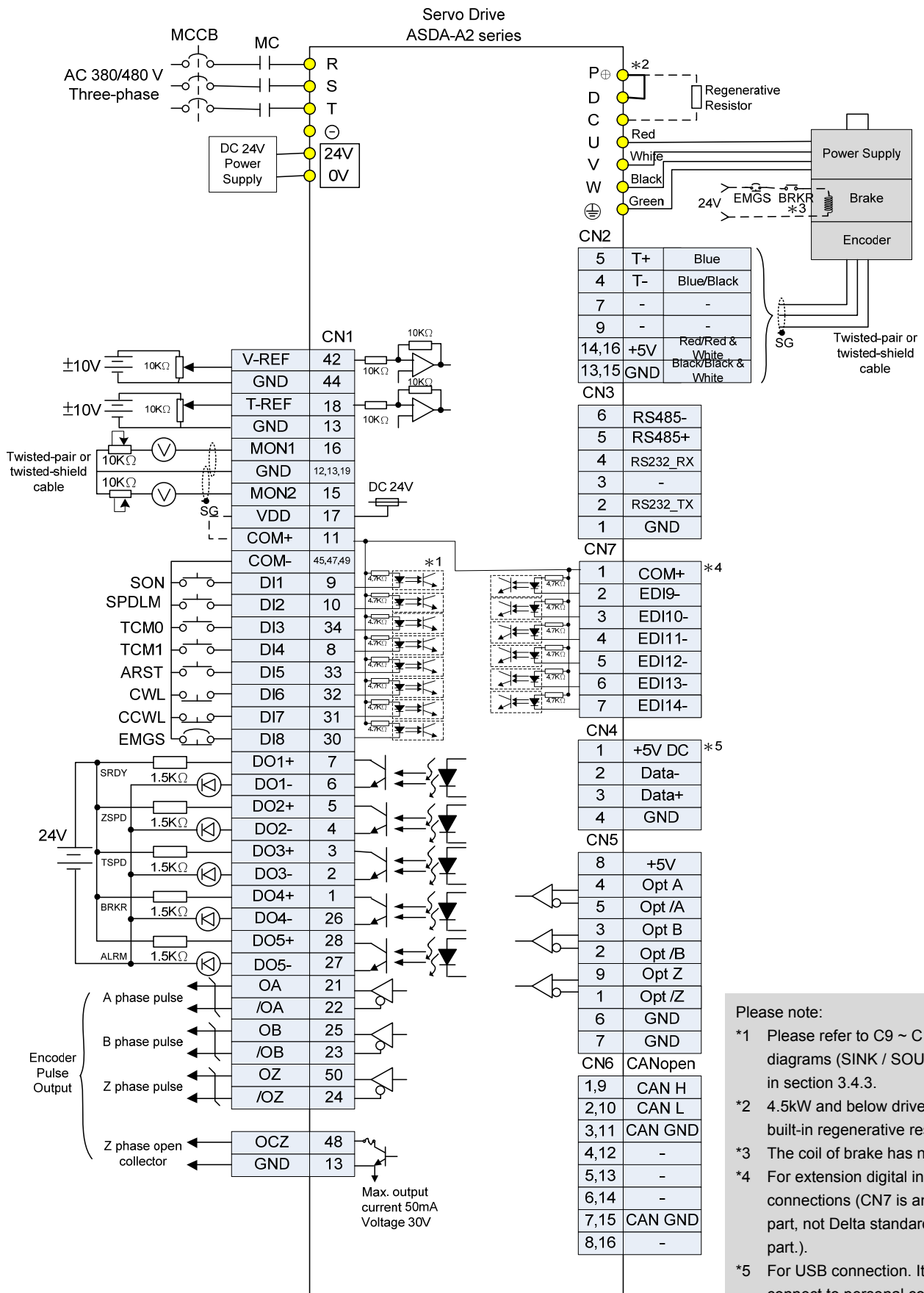

Please note:

- \*1 Please refer to C9 ~ C12 wiring diagrams (SINK / SOURCE mode) in section 3.4.3.
- \*2 4.5kW and below drives provide built-in regenerative resistor.
- \*3 The coil of brake has no polarity.
- \*4 For extension digital inputs (DI) connections (CN7 is an optional part, not Delta standard supplied part.).
- \*5 For USB connection. It is used to connect to personal computer or notebook.



### 3.13.5 Communication Mode

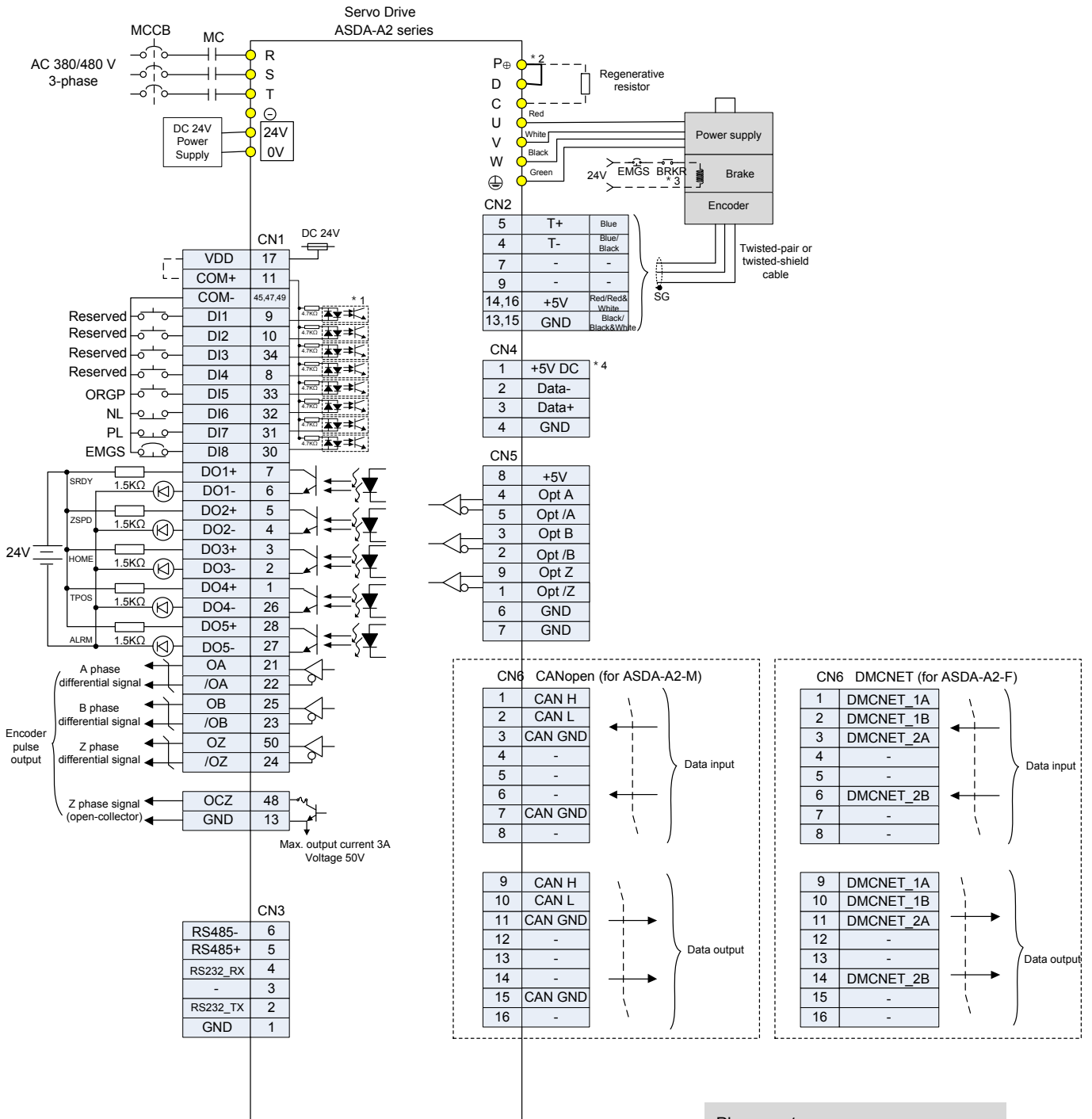

Please note:

- \*1 Please refer to C9 ~ C12 wiring diagrams (SINK / SOURCE mode) in section 3.4.4.
- \*2 4.5kW and below drives provide built-in regenerative resistor.
- \*3 The coil of brake has no polarity.
- \*4 For USB connection. It is used to connect to personal computer or notebook.
- \*5 A2-F only supports DMCNET mode.

# Chapter 4 Panel Display and Operation

This chapter details the panel status and operation of ADSA-A2 series servo drive.

## 4.1 Panel Description

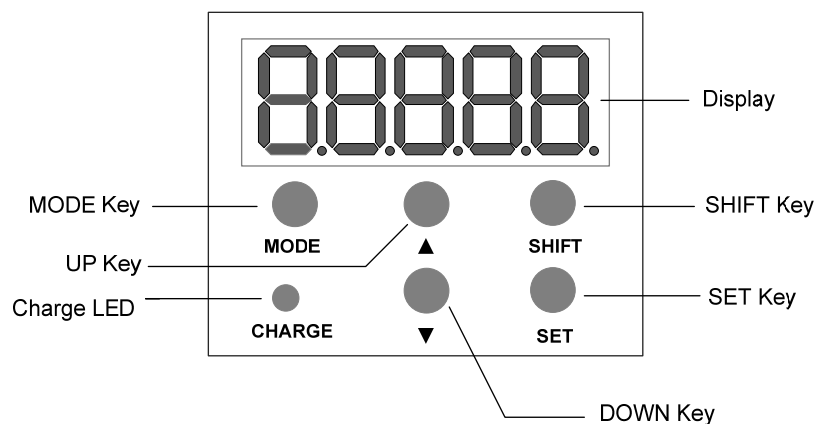

Name	Function
Display	Five-/Seven-segment display is for displaying the monitoring values, parameter values and setting values.
SHIFT Key	Pressing SHIFT key can scrolls through parameter groups. After a parameter is selected and its value displayed, pressing SHIFT key can move the cursor to the left and then change parameter settings by using arrow keys.
SET Key	Pressing the SET key can display and save the parameter groups, the various parameter settings. In monitor mode, pressing SET key can switch decimal or hexadecimal display. In parameter mode, pressing SET key can enter into parameter setting mode.
DOWN Key	Pressing the DOWN key can scroll through and change monitor codes, parameter groups and various parameter settings.
MODE Key	Pressing MODE key can enter or exit different parameter groups, and switch between Monitor mode and Parameter mode.
UP Key	Pressing the UP key can scroll through and change monitor codes, parameter groups and various parameter settings.
Charge LED	The Charge LED lights to indicate the power is applied to the circuit.

## 4.2 Parameter Setting Procedure

Switch the mode:

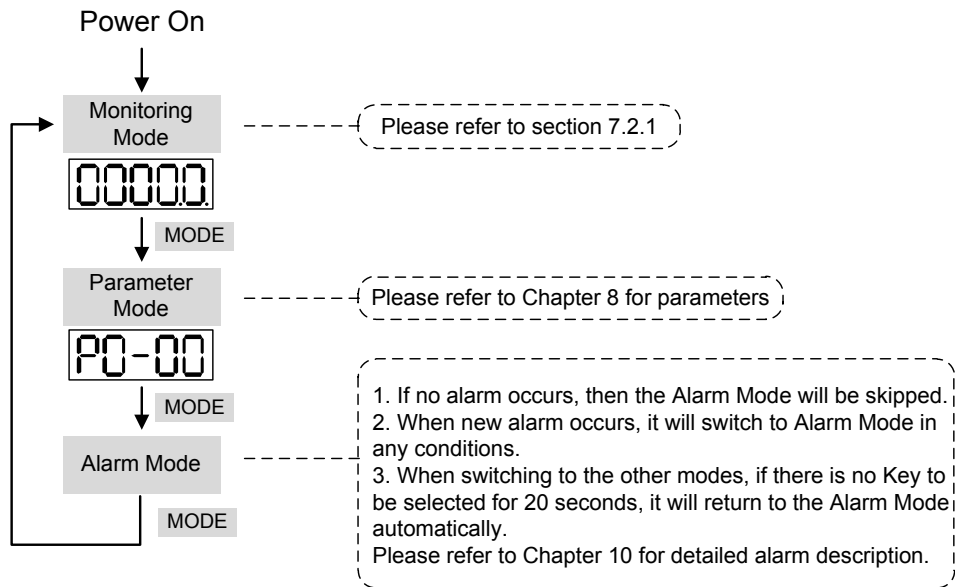

Operate in each mode:

Monitoring mode

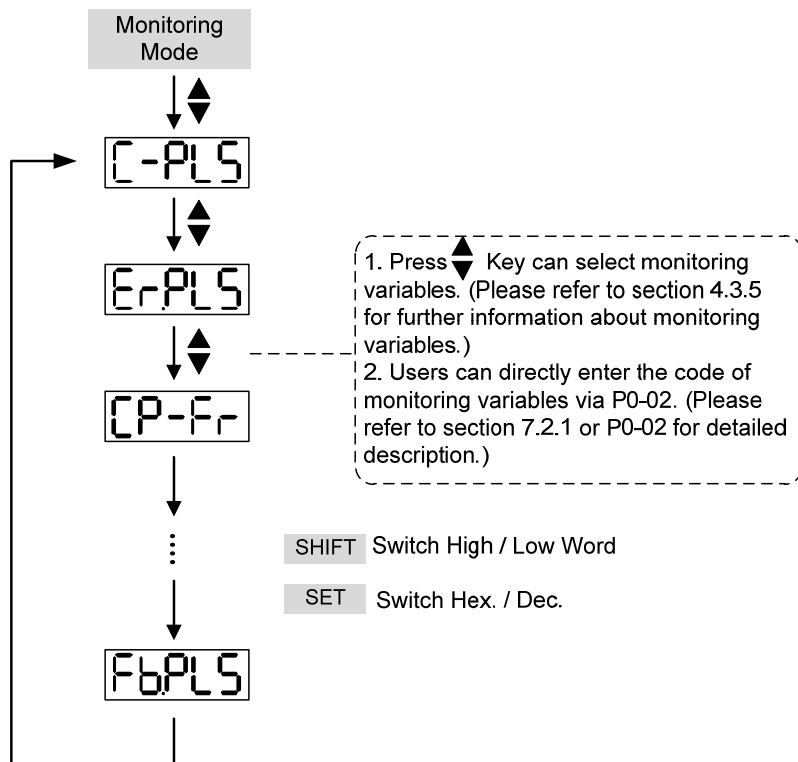

### Parameter Mode

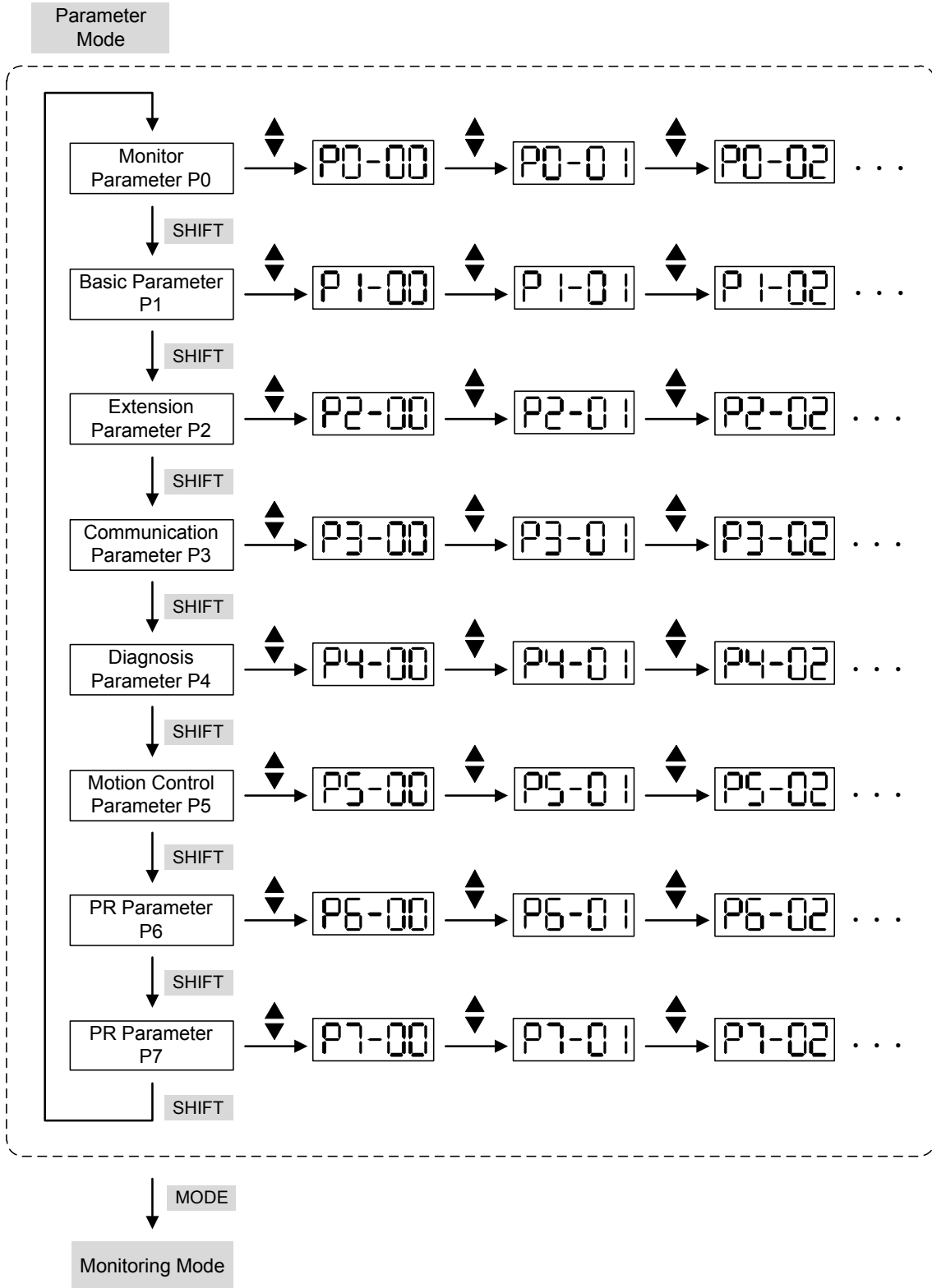

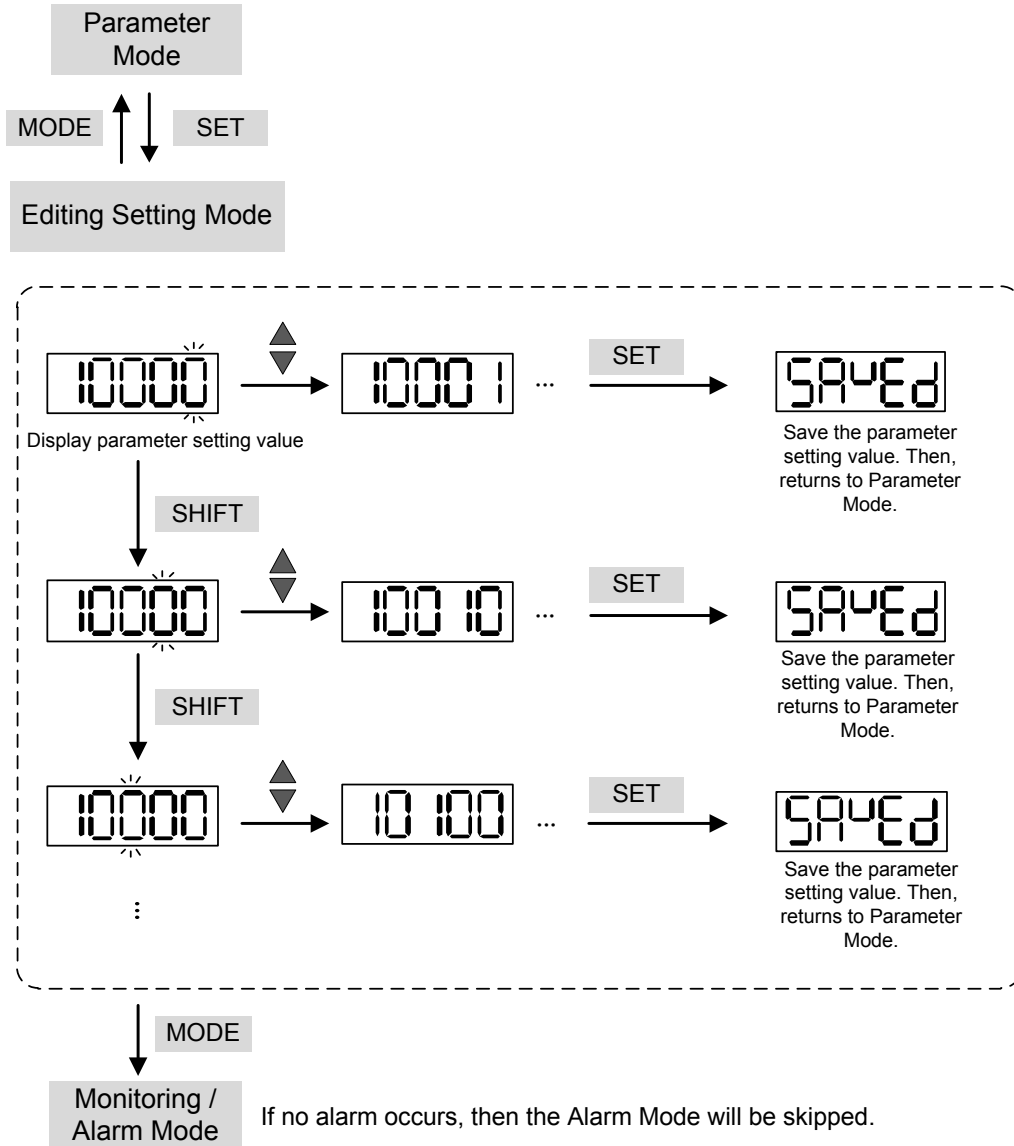

### Edit Setting Mode



## 4.3 Status Display

### 4.3.1 Save Setting Display

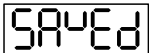
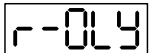
When finishing editing parameter, press the SET Key to save the setting. The panel will display the setting status according to the setting for a second.

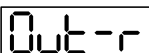
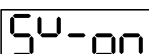
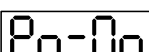
Displayed Symbol	Description
	The setting value is saved correctly. (Saved)
	Read-only parameter. Write-protected. (Read-Only)
	Enter the wrong password or no password has been entered. (Locked)
	Incorrect setting value or enter the reserved setting value. (Out of Range)
	No entering is allowed when it is Servo ON. (Servo On)
	Parameter will be effective after the servo drive is re-powered on. (Power On)

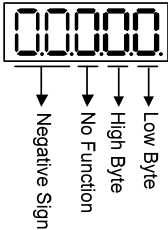

### 4.3.2 Decimal Point

Display Symbol	Description
	<p>High byte / low byte indication: When the data is displayed in decimal 32 bits, it is for indicating the current high or low byte.</p> <p>Negative sign: When the data is displayed in decimal format, the two decimal points in the left represents the negative sign, no matter it is showed in 16 or 32 bits. When it is showed in hexadecimal format, it only shows positive sign.</p>

### 4.3.3 Alarm Message

Displayed Symbol	Description
	When there is an error of the drive, it will show 'AL' as the alarm sign and 'nnn' as the alarm code. For further explanation, please refer to Chapter 8, P0-01, parameter description, or Chapter 10, Troubleshooting.

### 4.3.4 Positive and Negative Sign Setting

Displayed Symbol	Description
	When entering into the Editing Setting Mode, pressing UP / DOWN Key can increase or decrease the displayed content. The SHIFT Key can change the desired adjusted carry value. (The carry value is blinking at the moment.)
	Pressing the SHIFT Key for two seconds can switch the positive (+) and negative (-) sign. If the parameter is over the range after switching the positive or negative sign, then it cannot be switched.

### 4.3.5 Monitor Display



When the drive is applied to the power, the display will show the monitor displayed symbol for a second, and then enter into the Monitor Mode. In Monitor Mode, the UP / DOWN Key can change the desired monitor variable. Or, the user can directly change parameter P0-02 to set the monitor code. When applying to the power, the system will pre-set the monitor code according to the setting value of P0-02. For example, the setting value of P0-02 is 4. Every time when applying to the power, it will display C-PLS monitor sign first, and then shows the input pulse number of pulse command.

P0-02 Setting Value	Monitor Displayed Symbol	Description	Unit
0	FbPUU	Motor feedback pulse number (after the scaling of electronic gear ratio) (User unit)	[user unit]
1	C-PUU	Input pulse number of pulse command (after the scaling of electronic gear ratio) (User unit)	[user unit]
2	ErPUU	The difference of error pulse number between control command pulse and feedback pulse number (User unit)	[user unit]
3	FbPLS	Motor feedback pulse number (encoder unit) (1.28 millions Pulse/rev)	[pulse]
4	C-PLS	Input pulse number of pulse command (before the scaling of electronic gear ratio) (encoder unit)	[pulse]
5	ErPLS	Error pulse number (after the scaling of electronic gear ratio) (encoder unit)	[pulse]
6	CP-Fr	Input frequency of pulse command	[Kpps]
7	SPEED	Motor speed	[r/min]
8	CSPd1	Speed input command	[Volt]
9	CSPd2	Speed input command	[r/min]
10	C-t91	Torque input command	[Volt]
11	C-t92	Torque input command	[%]
12	AUG-L	Average torque	[%]
13	PE-L	Peak torque	[%]
14	U bus	Main circuit voltage	[Volt]
15	J-L	Load / Motor inertia ratio (Note: If it shows 13.0, it means the actual inertia is 13)	[1 times]
16	IGbtt	IGBT temperature	[°C]

P0-02 Setting Value	Monitor Displayed Symbol	Description	Unit
17		Resonance frequency (Low byte is the first resonance and high byte is the second one).	[Hz]
18		The absolute pulse number of encoder Z phase equals to the homing value, 0. It will be +5000 or -5000 pulse when rotating in forward or reverse direction.	-
19		Mapping parameter #1: shows the content of parameter P0-25 (specify the mapping target by P0-35)	-
20		Mapping parameter #2: shows the content of parameter P0-26 (specify the mapping target by P0-36)	-
21		Mapping parameter #3: shows the content of parameter P0-27 (specify the mapping target by P0-37)	-
22		Mapping parameter #4: shows the content of parameter P0-28 (specify the mapping target by P0-38)	-
23		Monitor variable #1: shows the content of parameter P0-09 (specify the monitor variable code by P0-17)	-
24		Monitor variable #2: shows the content of parameter P0-10 (specify the monitor variable code by P0-18)	-
25		Monitor variable #3: shows the content of parameter P0-11 (specify the monitor variable code by P0-19)	-
26		Monitor variable #4: shows the content of parameter P0-12 (specify the monitor variable code by P0-20)	-

Example of the displayed value	Status Description	
	16 bits	If the value is 1234, it displays 01234 (shows in decimal format).
		If the value is 0x1234, it displays 1234 (shows in hexadecimal format; the first digit does not show any).
 	32 bits	If the value is 1234567890, the display of the high byte is 1234.5 and displays 67890 as the low byte (shows in decimal format).

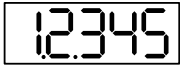

 (Hex high)  (Hex low)		<p>If the value is 0x12345678, the display of the high byte is h1234 and displays L5678 as the low byte (shows in hexadecimal format).</p>
	<p>Negative display. If the value is -12345, it displays 1.2.345 (only shows in decimal format; there is no positive or negative sign for hexadecimal format display).</p>	

 **NOTE**

- 1 ) Dec means it is displayed in decimal format. Hex means it is displayed in hexadecimal format.
- 2 ) The above display methods can be applied in Monitor Mode and Editing Setting Mode.
- 3 ) When all monitor variables is 32 bits, high / low bit and the display (Dec/Hex) can be switched. According to the definition in Chapter 8, each parameter only supports one displaying method and cannot be switched.

## 4.4 General Function

### 4.4.1 Operation of Fault Record Display

When it is in Parameter Mode, select P4-00~P4-04 and press the SET Key, the corresponding fault record will be shown.

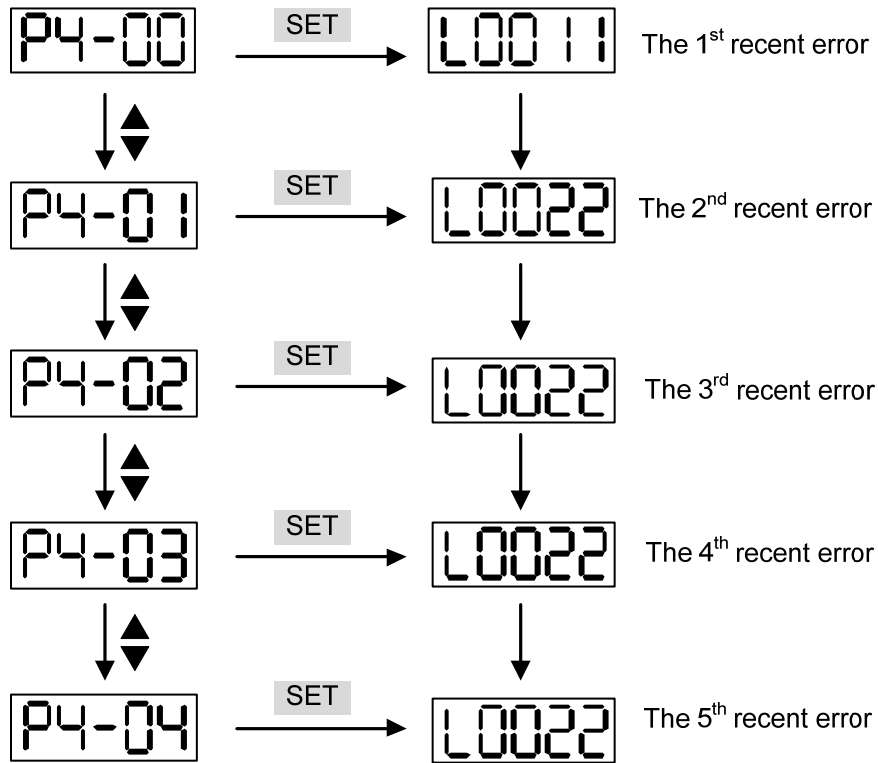

### 4.4.2 JOG Mode

When it is in Parameter Mode, select P4-05 and follow the setting method below for JOG operation.

- (1) Press the SET Key to display the speed value of JOG. The default value is 20r/min.
- (2) Press UP or DOWN Key to adjust the desired speed value of JOG. It is adjusted to 100r/min in the example.
- (3) Press the SET Key to display JOG and enter JOG mode.
- (4) When it is in JOG Mode, press UP or DOWN Key to enable the servo motor in forward or reverse direction. The servo motor stops running as soon as the user stops pressing the key. JOG operation is working only when it is Servo ON.

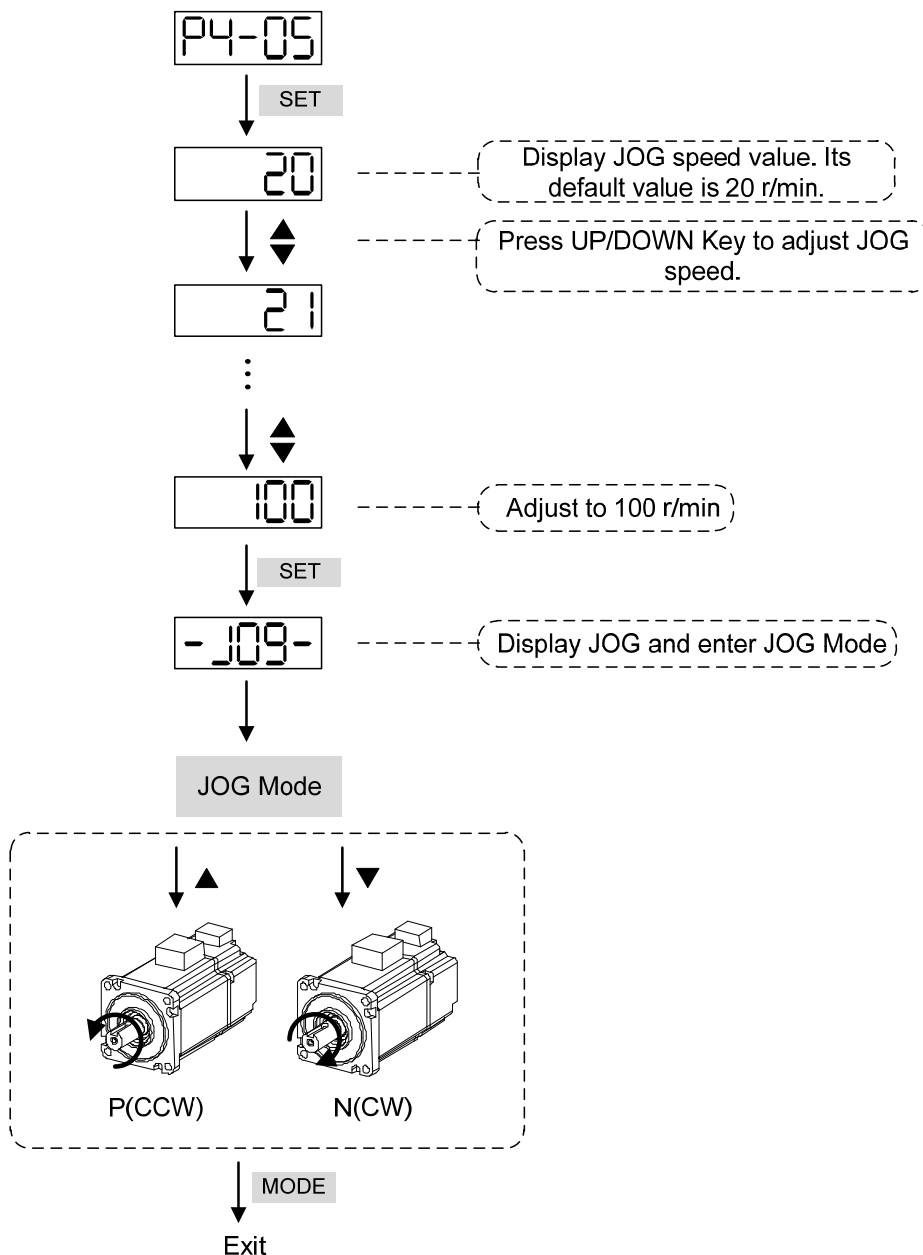

### 4.4.3 Force DO Output

Enter into the Output Diagnosis Mode by the following settings. Set P2-08 to 406 and enable the function of force DO output. Then, set the force DO output by binary method via P4-06. When the setting value is 2, DO2 will be forced to enable. When the setting value is 5, DO1 and DO3 will be forced to enable. No data is retained in this mode. It returns to the normal DO mode when re-power on the drive or set P2-08 to 400.

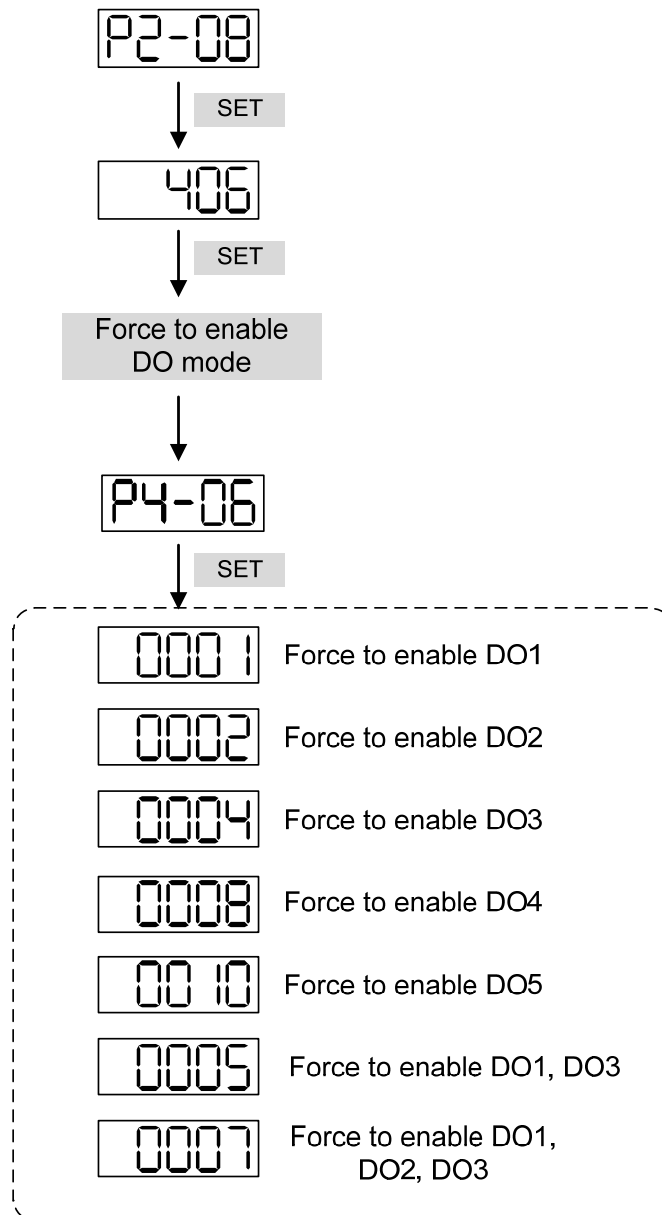

#### NOTE

P4-06 is displayed in hexadecimal format. Therefore, it will not show the fifth 0.

### 4.4.4 Digital Input Diagnosis Operation

Enter into the Digital Input Diagnosis Mode by the following setting methods. When the external output signal DI1~DI8 is ON, the corresponding signal will be shown on the panel. It is displayed by bit. When it shows bit, it means it is ON.

For example, if it shows **3FE1**, **E** is in hexadecimal format, it will be **1100** when it transfers to binary format. Then, DI6~DI8 is ON.

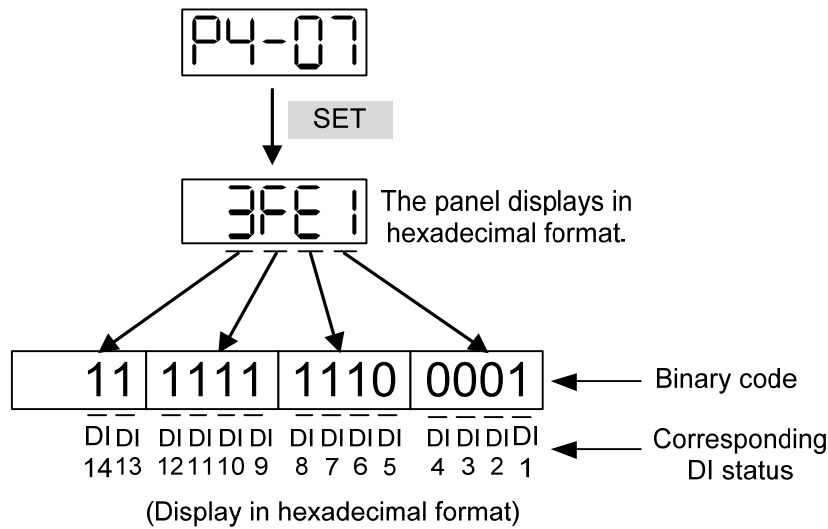

### 4.4.5 Digital Output Diagnosis Operation

Enter into the Digital Output Diagnosis Mode by the following setting methods. The output signal DO1~DO5 is ON and the corresponding signal will be shown on the panel. It is displayed by bit. When it shows bit, it means it is ON.

For example, if it shows **1F**, **F** is in hexadecimal format, it will be **1111** when it transfers to binary format. Then, DO1~DO4 is ON.

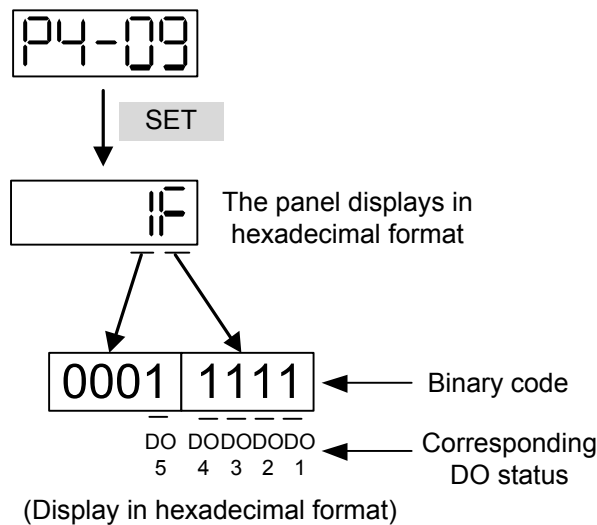

# Chapter 5 Trial Operation and Tuning

This chapter is divided into two parts to describe the trial operation. The first one is the inspection without load and another one is the inspection with load. For safety reasons, please conduct the first inspection.

## 5.1 Inspection without Load

Please remove the load of the servo motor, including coupling on the shaft and accessories so as to avoid any damage on servo drive or mechanism. This is aiming to avoid the falling off of the disassembled parts of the motor shaft and indirectly causing the personnel injury or equipment damage during operation. Running the motor without load, if the servo motor can run during normal operation, then it can connect to load for operation.

**Caution: Please operate the servo motor without load first. If the servo motor runs normally, connect the load afterwards in order to avoid any danger.**

**Please check the following items before operation.**

### Inspection before operation (has not applied to the power yet)

- Check if there is any obvious damage shown on its appearance.
- The splicing parts of the wiring terminal should be isolated.
- Make sure the wiring is correct so as to avoid the damage or any abnormality.
- Check if the electric conductivity objects including sheetmetal (such as screws) or inflammable objects are not inside the servo drive.
- Check if the control switch is in OFF status.
- Do not place the servo drive or external regenerative resistor on inflammable objects.
- To avoid the electromagnetic brake losing efficacy, please check if stop function and circuit break function can work normally.
- If the peripheral devices are interfered by the electronic instruments, please reduce electromagnetic interference with devices.
- Please make sure the external voltage level of the servo drive is correct.

### Inspection before running the servo drive (has already applied to the power)

- The encoder cable should avoid excessive stress. When the motor is running, make sure the cable is not frayed or over extended.

- Please contact with Delta if there is any vibration of the servo motor or unusual noise during the operation.
- Make sure the setting of the parameters is correct. Different machinery has different characteristic, please adjust the parameter according to the characteristic of each machinery.
- Please reset the parameter when the servo drive is in SERVO OFF status, or it may cause malfunction.
- When the relay is operating, make sure it can work properly.
- Check if the power indicator and LED display works normally.
- PWM is used to control 7.5 kW. Thus, when the temperature is lower than 40°C, the fan does not work.

## 5.2 Applying Power to the Servo Drive

Please follow the instructions below.

**A.** Make sure the wiring between the motor and servo drive is correct.

- 1) U, V, W and FG have to connect to cable red, white, black and green respectively. If the wiring is incorrect, the motor cannot work normally. The ground wire FG of the motor must be connected to the ground terminal of the servo drive. Please refer to Chapter 3.1 and 3.2 for wiring.
- 2) The encoder cable of the motor has correctly connected to CN2: If users only desire to execute JOG function, it is unnecessary to connect CN1 and CN3 (Please refer to Chapter 5.3). Refer to Chapter 3.1 and 3.5 for the wiring of CN2.

**Caution:** Do not connect the power terminal (R, S, T) to the output terminal (U, V, W) of the servo drive. Or it might damage the servo drive.

**B.** Power circuit of the servo drive:

**Caution:** Wiring of 220 V servo drive is different from 400 V. Make sure the wiring is correct, or it might damage the servo drive.

**220V Servo Drive:** Apply power to the servo drive. Please refer to Chapter 3.1.3 for power wiring.

**400V Servo Drive:** Apply power to the servo drive. Please refer to Chapter 3.2.3 for power wiring.

**C.** Power on:

**220V Servo Drive:** Power of the servo drive: including control circuit (L1c, L2c) and main circuit (R, S, T) power.

**400V Servo Drive:** Power of the servo drive: including control circuit (DC24V, DC0V) and main circuit (R, S, T) power.

When the power is on, the display of the servo drive will be:

AL013

The digital input (DI6~DI8) of the default value is the signal of reverse limit error (NL), forward limit error (PL) and emergency stop (EMGS), if not using the default setting of DI6~DI8, adjusting the setting of P2-15~P2-17 is a must. Parameters could be set to 0 (disable this DI

function) or modified to another function.

From the last setting, the servo drive status displays parameter P0-02 setting as the motor speed (07), then the screen display will be:

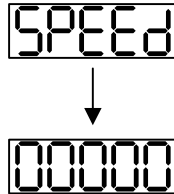

When the screen displays no text, please check if the power of control circuit is under voltage.

1) When the screen displays:

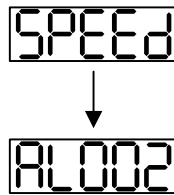

Warning of overvoltage:

It means the voltage input by the main circuit is higher than the rated voltage or power input error (incorrect power system).

Corrective action:

- Use the voltmeter to measure if the input voltage from the main circuit is within the range of rated voltage value.
- Use the voltmeter to measure if the power system complies with the specification.

2) When the screen displays:

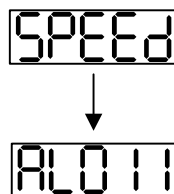

Warning of encoder error:

Check if the motor encoder is securely connected or the wiring is correct.

Corrective action:

- Check if the wiring is the same as the instruction of the user manual.
- Check the encoder connector.
- Check if the wiring is loose.
- Encoder is damaged.



3) When the screen displays:

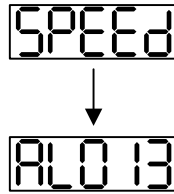

Warning of emergency stop:

Please check if any of the digital input DI1~DI8 is set to emergency stop (EMGS).

Corrective action:

- If not desire to set emergency stop (EMGS) as one of the digital input, make sure no digital input is set to emergency stop (EMGS) among DI1~DI8. (That is to say none of the parameters, P2-10~P2-17 is set to 21.)
- If the function of emergency stop (EMGS) is needed and this DI is set as normally close (function code: 0x0021), please make sure this DI is always normally close. If not, please set this DI as normally open (function code: 0x0121).

4) When the screen displays:

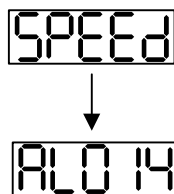

Warning of negative limit error:

Please check if any of the digital input DI1~DI8 is set to negative limit (NL) and that DI is ON.

Corrective action:

- If not desire to set negative limit (NL) as one of the digital input, make sure no digital input is set to negative limit (NL) among DI1~DI8. (That is to say none of the parameters, P2-10~P2-17 is set to 22.)
- If the function of negative limit (NL) is needed and this DI is set as normally close (function code: 0x0022), please make sure this DI is always normally close. If not, please set this DI as normally open (function code: 0x0122).

5) When the screen displays:

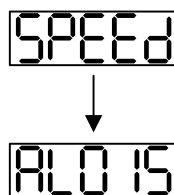

Warning of positive limit error:

Please check if any of the digital input DI1~DI8 is set positive limit (PL) and that DI is ON.

Corrective action:

- If not desire to set positive limit (PL) as one of the digital input, make sure no digital input is set to positive limit (PL) among DI1~DI8. (That is to say none of the parameters, P2-10~P2-17 is set to 23.)
- If the function of positive limit (PL) is needed and this DI is set as normally close (function code: 0x0023), please make sure this DI is always normally close. If not, please set this DI as normally open (function code: 0x0123).

6) When the screen displays:

A digital display showing the code 'AL001' in a rectangular frame.

Warning of over current:

Corrective Action:

- Check the connection between the motor and servo drive.
- Check if the conducting wire is short circuited.

Exclude short circuit and avoid metal conductors being exposed.

7) When the screen displays:

A digital display showing the code 'AL003' in a rectangular frame.

Warning of under voltage:

Corrective action:

- Check if the wiring of main circuit input voltage is correct.
- Use voltmeter to measure if the main circuit voltage is normal.
- Use voltmeter to measure if the power system complies with the specification.



---

During the process of power on or servo on, if an alarm occurs or shows any abnormal display, please contact the distributors.

### 5.3 JOG Trial Run without Load

It is very convenient to test the motor and servo drive with the method of JOG trial run without load since the extra wiring is unnecessary. For safety reasons, it is recommended to set JOG at low speed. Please see the following descriptions.

**Step 1:** Use software setting to Servo ON. Set parameter P2-30 to 1. This setting is to force the servo ON through software.

**Step 2:** Set P4-05 as JOG speed (Unit: r/min). After setting the desired JOG speed, press the **SET** Key, the servo drive will enter JOG mode.

**Step 3:** Press the **MODE** Key to exist JOG mode.

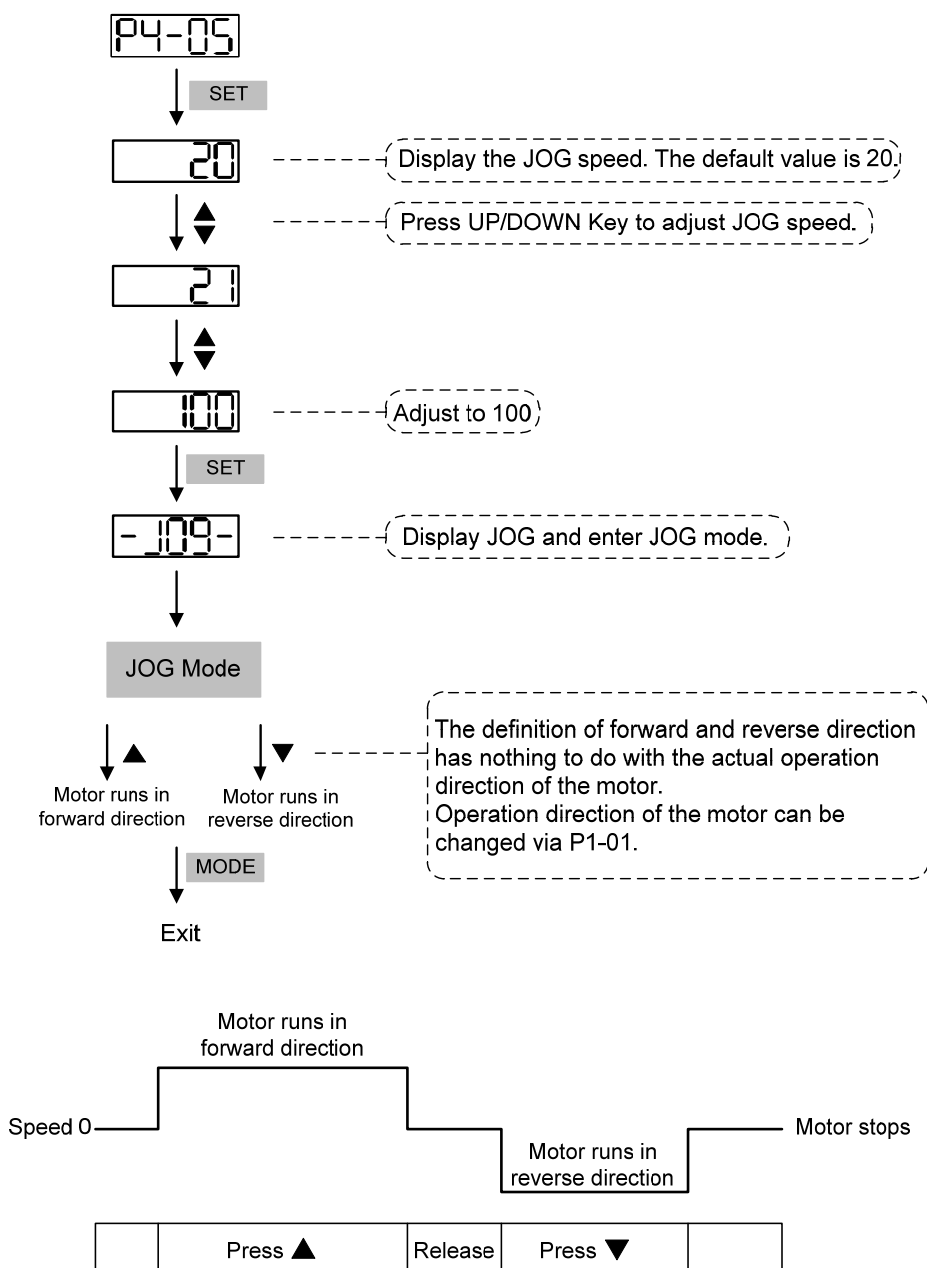

If the motor does not run, please check if the wiring between UVW and encoder cable is correct.  
 If the motor run abnormally, please check if the UVW phase sequence is correct.

## 5.4 Trial Run without Load (Speed Mode)

Before the trial run without load, firmly secure the motor base so as to avoid the danger cause by the reaction of motor operation.

### Step 1:

Set the control mode of the servo drive to speed mode. Set P1-01 to 2 as speed mode. Then, re-power on the servo drive.

### Step 2:

In speed control mode, the digital input settings of trial run are as follows:

Digital Input	Parameter Setting Value	Symbol	Function Description	CN1 Pin No
DI1	P2-10 = 101	SON	Servo ON	DI1- = 9
DI2	P2-11 = 109	TRQLM	Torque limit	DI2- = 10
DI3	P2-12 = 114	SPD0	Speed command selection	DI3- = 34
DI4	P2-13 = 115	SPD1	Speed command selection	DI4- = 8
DI5	P2-14 = 102	ARST	Alarm reset	DI5- = 33
DI6	P2-15 = 0	Disabled	Invalid DI function	-
DI7	P2-16 = 0	Disabled	Invalid DI function	-
DI8	P2-17 = 0	Disabled	Invalid DI function	-
EDI9	P2-36 = 0	Disabled	Invalid DI function	CN7 = 2
EDI10	P2-37 = 0	Disabled	Invalid DI function	CN7 = 3
EDI11	P2-38 = 0	Disabled	Invalid DI function	CN7 = 4
EDI12	P2-39 = 0	Disabled	Invalid DI function	CN7 = 5
EDI13	P2-40 = 0	Disabled	Invalid DI function	CN7 = 6
EDI14	P2-41 = 0	Disabled	Invalid DI function	CN7 = 7

The above table disables the function of negative limit (DI6), positive limit (DI7) and emergency stop (DI8). Thus, the value of parameter P2-15 ~ P2-17 and P2-36 ~ P2-41 are set to 0 (Disabled).

The digital input of Delta' s servo drive can be programmed by users. When programming digital input, please refer to the description of DI code.

The default setting includes the function of negative limit, positive limit and emergency stop, therefore, after the setting is completed, if there is any alarm occurs, please re-power on the servo drive or switch ON DI5 to clear the alarm. Please refer to Chapter 5.2.

The speed command selection is determined by SPD0 and SPD1. See the table below.

Speed Command No.	DI signal of CN1		Command Source	Content	Range
	SPD1	SPD0			
S1	0	0	External analog command	Voltage deviation between V-REF and GND	-10V ~ +10V
S2	0	1	Register parameter	P1-09	-60000 ~ 60000
S3	1	0		P1-10	-60000 ~ 60000
S4	1	1		P1-11	-60000 ~ 60000

0: means DI is OFF; 1: means DI is ON

#### Register parameter

The parameter setting range is from -60000 to 60000. Setting speed = Setting range x unit (0.1 r/min).

For example: P1-09 = +30000; Setting speed = +30000 x 0.1 r/min = +3000 r/min

#### Command setting of speed register

Set parameter P1-09 to 30000.

Set parameter P1-10 to 1000.

Set parameter P1-11 to -30000.

Input command	Rotation direction
+	CW
-	CCW

#### Step 3:

- (1) Users switch ON DI1 and Servo ON.
- (2) Both DI3 (SPD0) and DI4 (SPD1), the speed command, are OFF, which means it currently executes S1 command. The motor rotates according to analog voltage command.
- (3) When DI3 (SPD0) is ON, it means it currently executes S2 command (3000 r/min). The rotation speed is 3000 r/min for rotary motor and 0.03 m/s for linear motor at the moment.
- (4) When DI4 (SPD1) is ON, it means it currently executes S3 command (100 r/min). The rotation speed is 100 r/min.
- (5) When both DI3 (SPD0) and DI4 (SPD1) are ON, it means S4 command (-3000 r/min) is executed at the moment. The rotation speed is -3000 r/min.
- (6) Step (3), (4) and (5) can be repeatedly executed.
- (7) If users desire to stop the motor, switch OFF DI1 (Servo OFF).

## 5.5 Trial Run without Load (Position Mode)

Before the trial run without load, firmly secure the motor base so as to avoid the danger cause by the reaction of motor operation.

### Step 1:

Set the control mode of the servo drive to position mode.

Set parameter P1-01 to 1, which is the position mode. Then, re-power on the servo drive.

**Step 2:** In position mode, the digital input settings of trial run are as follows:

Digital Input	Parameter Setting Value	Symbol	Function Description	CN1 Pin No
DI1	P2-10 = 101	SON	Servo ON	DI1- = 9
DI2	P2-11 = 108	CTRG	Command triggered	DI2- = 10
DI3	P2-12 = 111	POS0	Position command selection	DI3- = 34
DI4	P2-13 = 112	POS1	Position command selection	DI4- = 8
DI5	P2-14 = 102	ARST	Alarm reset	DI5- = 33
DI6	P2-15 = 0	Disabled	Invalid DI function	-
DI7	P2-16 = 0	Disabled	Invalid DI function	-
DI8	P2-17 = 0	Disabled	Invalid DI function	-
EDI9	P2-36 = 0	Disabled	Invalid DI function	CN7 = 2
EDI10	P2-37 = 0	Disabled	Invalid DI function	CN7 = 3
EDI11	P2-38 = 0	Disabled	Invalid DI function	CN7 = 4
EDI12	P2-39 = 0	Disabled	Invalid DI function	CN7 = 5
EDI13	P2-40 = 0	Disabled	Invalid DI function	CN7 = 6
EDI14	P2-41 = 0	Disabled	Invalid DI function	CN7 = 7

The above table disables the function of negative limit (DI6), positive limit (DI7) and emergency stop (DI8), thus, set P2-15 ~ P2-17 and P2-36 ~ P2-41 to 0 (Disabled). The digital input of Delta's servo drive can be programmed by users. When programming digital input, please refer to the description of DI code.

The default setting includes the function of negative limit, positive limit and emergency stop, therefore, after the setting is completed, if there is any alarm occurs, please re-power on the servo drive or switch ON DI5 to clear the alarm. Please refer to Chapter 5.2.

Please refer to Chapter 3.12.2, Position (PR) Mode Standard Wiring for wiring diagram. However, since POS2 is not the default digital input, set P2-14 to 113. Please refer to the table below for 64 sets of register command, POS0~POS5 and the relative parameters.

Position Command	POS5	POS4	POS3	POS2	POS1	POS0	CTRG	Corresponding Parameter
PR0	0	0	0	0	0	0	↑	P6-00
								P6-01
PR1	0	0	0	0	0	1	↑	P6-02
								P6-03
~								~
PR50	1	1	0	0	1	0	↑	P6-98
								P6-99
PR51	1	1	0	0	1	1	↑	P7-00
								P7-01
~								~
PR64	1	1	1	1	1	1	↑	P7-26
								P7-27

0: means DI is OFF; 1: means DI is ON

Users can set the 64-set of command value (P6-00~P7-27). The value can be set as the absolute position command.

## 5.6 Tuning Procedure

Estimate the inertia ratio: JOG Mode

Tuning Procedure	Display
1. After completing wiring, when applying to the power, the servo drive will display:	AL013
2. Press the <b>MODE</b> Key to select the mode of parameter function.	P0-00
3. Press the <b>SHIFT</b> Key twice to select the mode of parameter group.	P2-00
4. Press the <b>UP</b> Key to select parameter P2-17.	P2-17
5. Press the <b>SET</b> Key to display parameter value, which is shown as the content on the right.	21
6. Press the <b>SHIFT</b> Key twice, then press the <b>UP</b> Key and then press the <b>SET</b> Key.	121
7. Press the <b>UP</b> Key to select parameter P2-30.	P2-30
8. Press the <b>SET</b> Key to display the parameter value.	0
9. Press the <b>UP</b> Key and select the parameter value 1.	1
10. Then, the servo drive is ON and will show:	0
11. Press the <b>MODE</b> Key and then press the <b>DOWN</b> Key to select the value of inertia ratio.	JL
12. The panel displays the current value of inertia ratio / total weight of movable section and load (kg) (default value).	50
13. Press the <b>MODE</b> Key to select the mode of parameter function.	P2-30
14. Press the <b>SHIFT</b> Key twice to select the mode of parameter group.	P4-00
15. Press the <b>UP</b> Key twice to select parameter P4-05.	P4-05
16. Press the <b>SET</b> Key to show the content, which is 20r/min at JOG speed. Press the <b>UP</b> or <b>DOWN</b> Key to increase or decrease the JOG speed. Press the <b>SHIFT</b> Key to move to the next digit of the left.	20 ↓ 200
17. Set the desired JOG speed and press the <b>SET</b> Key which is shown as the figure on the right.	-J09-
18. Press the <b>UP</b> Key to rotate the motor in forward direction while press the <b>DOWN</b> Key the motor will rotate in reverse direction.	
19. Execute JOG operation at low speed first. With the constant speed, if the motor operates smoothly in forward and reverse direction, users can execute JOG operation at higher speed.	
20. In P4-05, the servo drive cannot display inertia ratio. Please press the <b>MODE</b> Key twice to view the value of inertia ratio. If users desire to execute JOG operation again, press the <b>MODE</b> Key, and then press the <b>SET</b> Key twice. Observe the panel display to see if the load inertia ratio / total weight of movable section and load remain at the same value after acceleration and deceleration.	



### 5.6.1 Flowchart of Tuning Procedure

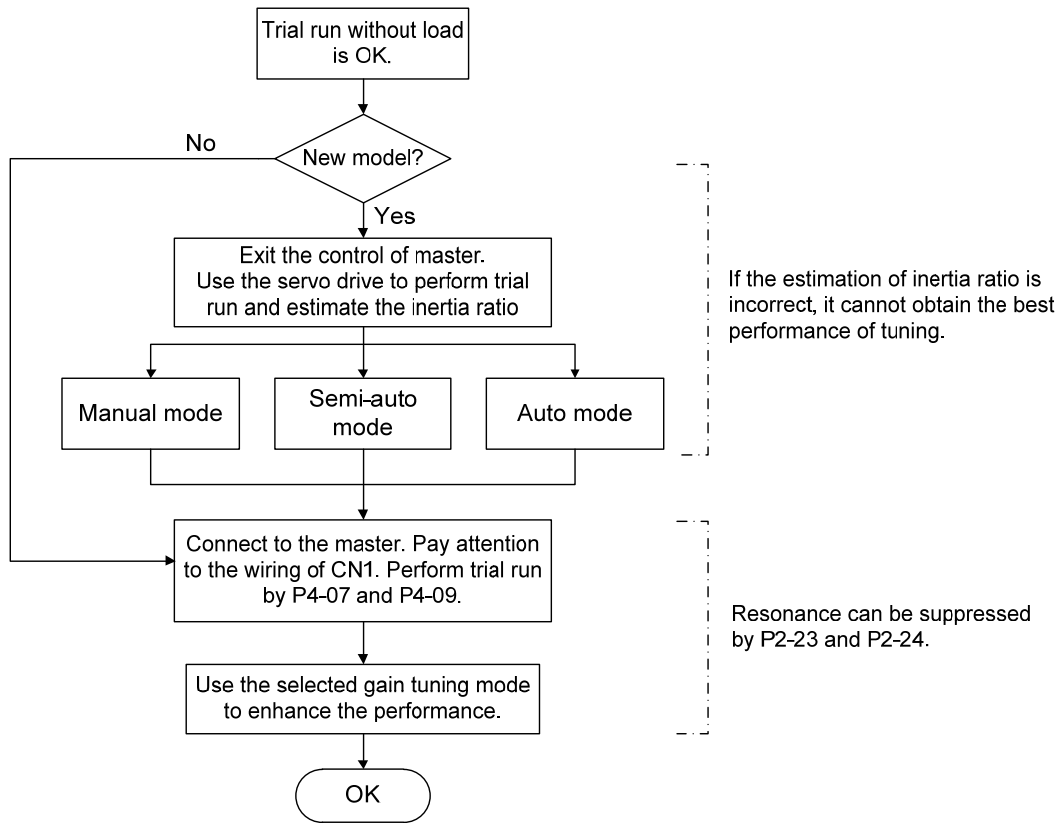

### 5.6.2 Inertia Estimation Flowchart (with Mechanism)

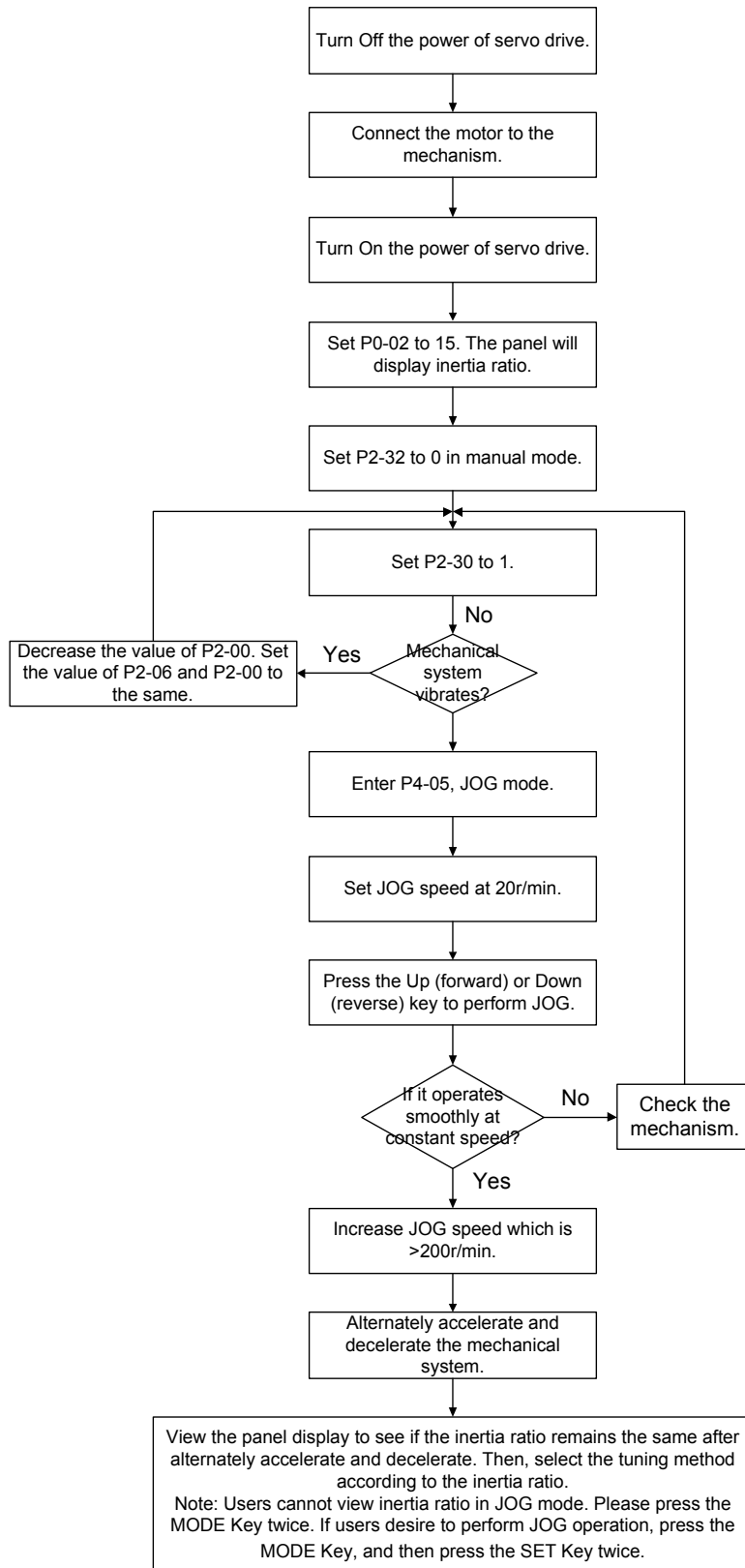

### 5.6.3 Flowchart of Auto Tuning

Set P2-32 to 1 (auto mode, continuous tuning)

Continue to estimate the system inertia. Automatically save the value in P1-37 every 30 minutes and refer the stiffness and bandwidth setting of P2-31.

P2-31 Stiffness setting in auto tuning mode (The default value is 80)

In auto and semi-auto mode, the bandwidth setting of speed circuit is:

1 ~ 50 Hz: low-stiffness, low-response

51 ~ 250 Hz: medium-stiffness, medium-response

251 ~ 850 Hz: high-stiffness, high-response

851 ~ 1000 Hz: extremely high-stiffness, extremely high-response

Stiffness setting in auto tuning mode: the bigger the value is, the stronger the stiffness will be.

Adjust the value of P2-31: Increase the value of P2-31 to increase stiffness or decrease to reduce the noise. Continue to tune until the performance is satisfied. Then, tuning is completed.

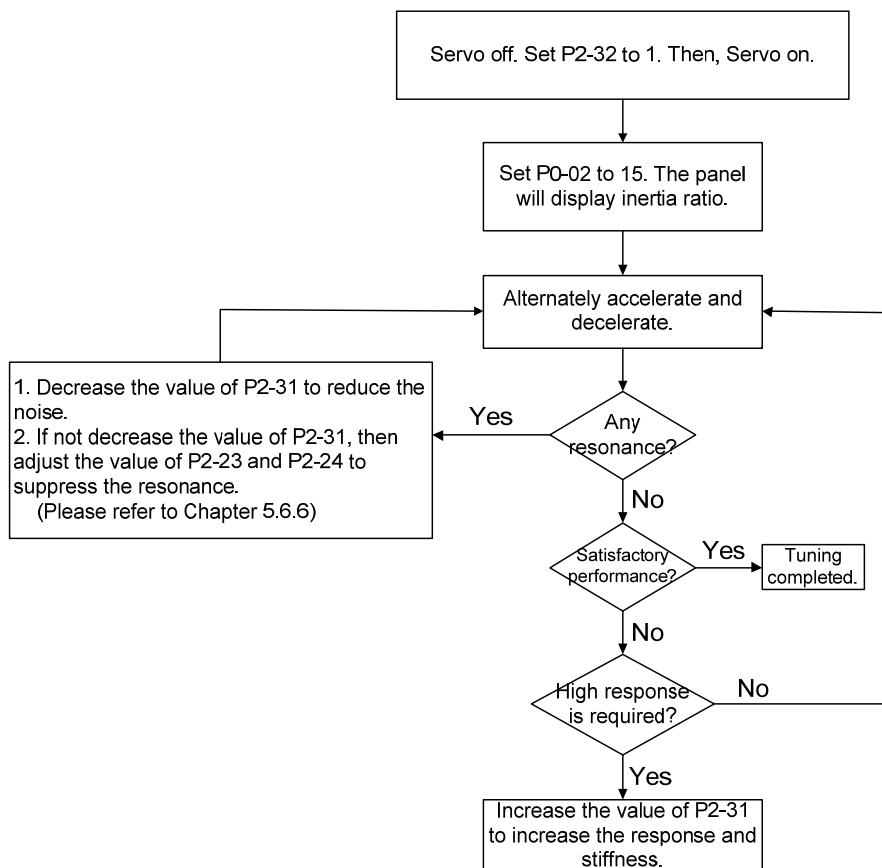

### 5.6.4 Flowchart of Semi-Auto Tuning

Set P2-32 to 2 (semi-auto mode, non-continuous tuning)

After tuning for a while and wait until the system inertia is stable, it stops estimating. The estimated inertia ratio will be saved to P1-37. When switching mode from manual or auto to semi auto, the system starts tuning again. During the process of estimation, the system will refer the stiffness and bandwidth setting of P2-31.

P2-31 Response setting in auto mode (The default value is 80)

In auto and semi-auto mode, the bandwidth setting of speed circuit is:

1 ~ 50 Hz: low-stiffness, low-response

51 ~ 250 Hz: medium-stiffness, medium-response

251 ~ 850 Hz: high-stiffness, high-response

851 ~ 1000 Hz: extremely high-stiffness, extremely high-response

Response setting in semi-auto tuning mode: the bigger the value is, the better the response will be.

Adjust the value of P2-31: Increase the value of P2-31 to increase the response or decrease to reduce the noise. Continue to tune until the performance is satisfied. Then, tuning is completed.

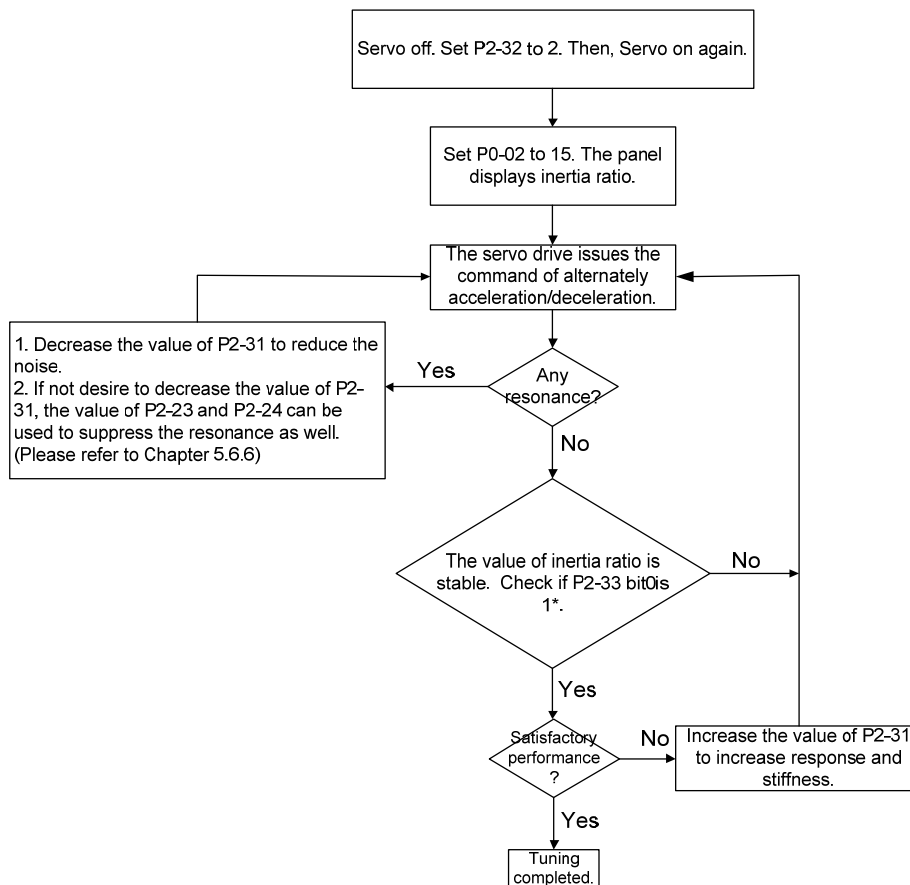

#### NOTE

1. If P2-33 bit 0 is set to 1, it means the inertia estimation in semi-auto mode is completed. The result can be accessed by P1-37.
2. If the value of P2-33 bit 0 is cleared to 0, the system will start to estimate again.

### 5.6.5 Limit of Inertia Ratio

Acceleration / Deceleration time of reaching 2000 r/min should be less than 1 second.

The speed in forward and reverse direction should be higher than 200 r/min.

The load inertia should be under 100 times of motor inertia.

The change of external force of inertia ratio cannot be too severe.

In auto mode, the inertia value will be saved to P1-37 every 30 minutes; while in semi-auto mode, the inertia value will be saved to P1-37 only until the system inertia is stable and stops the estimation of load inertia.

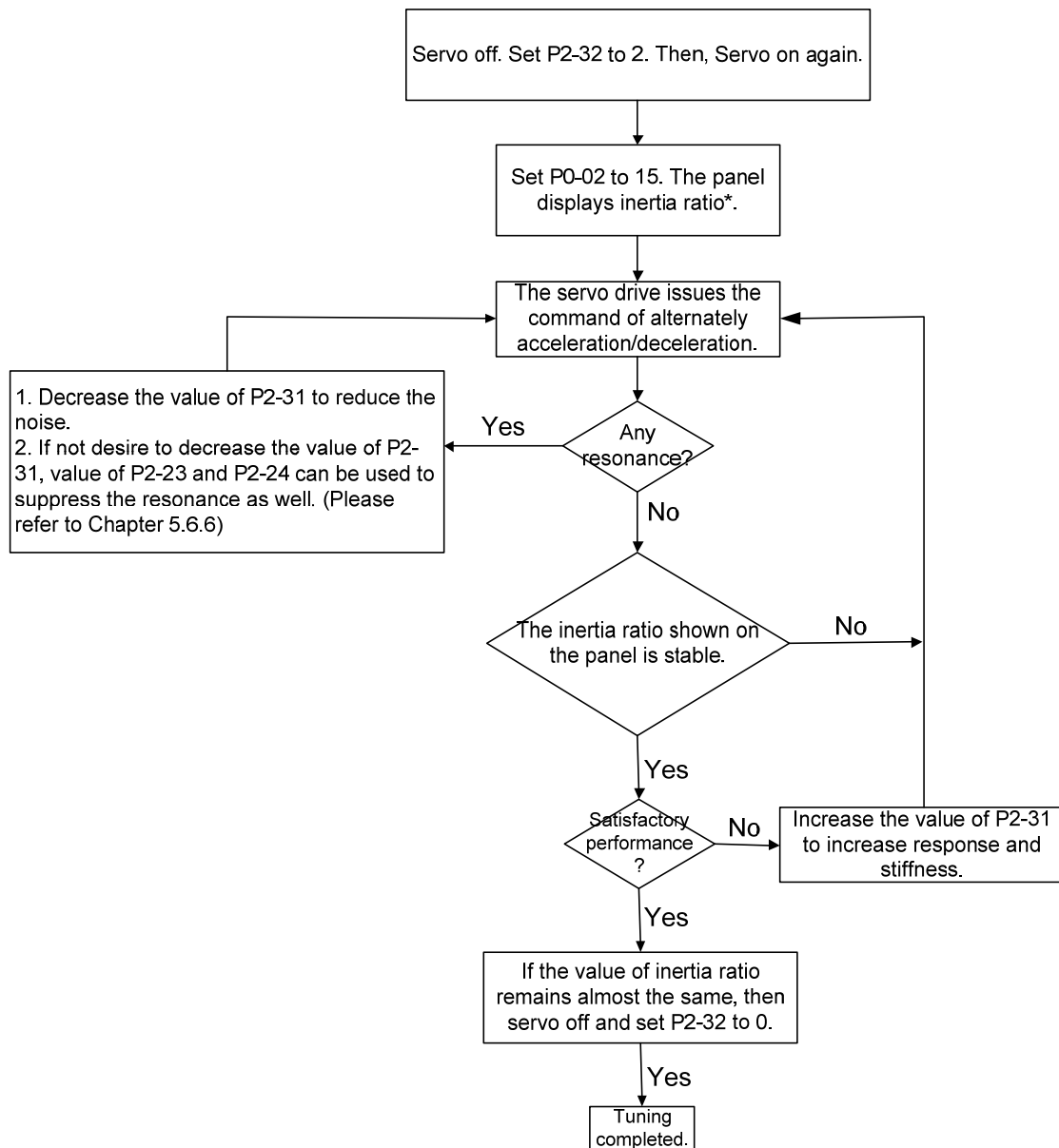

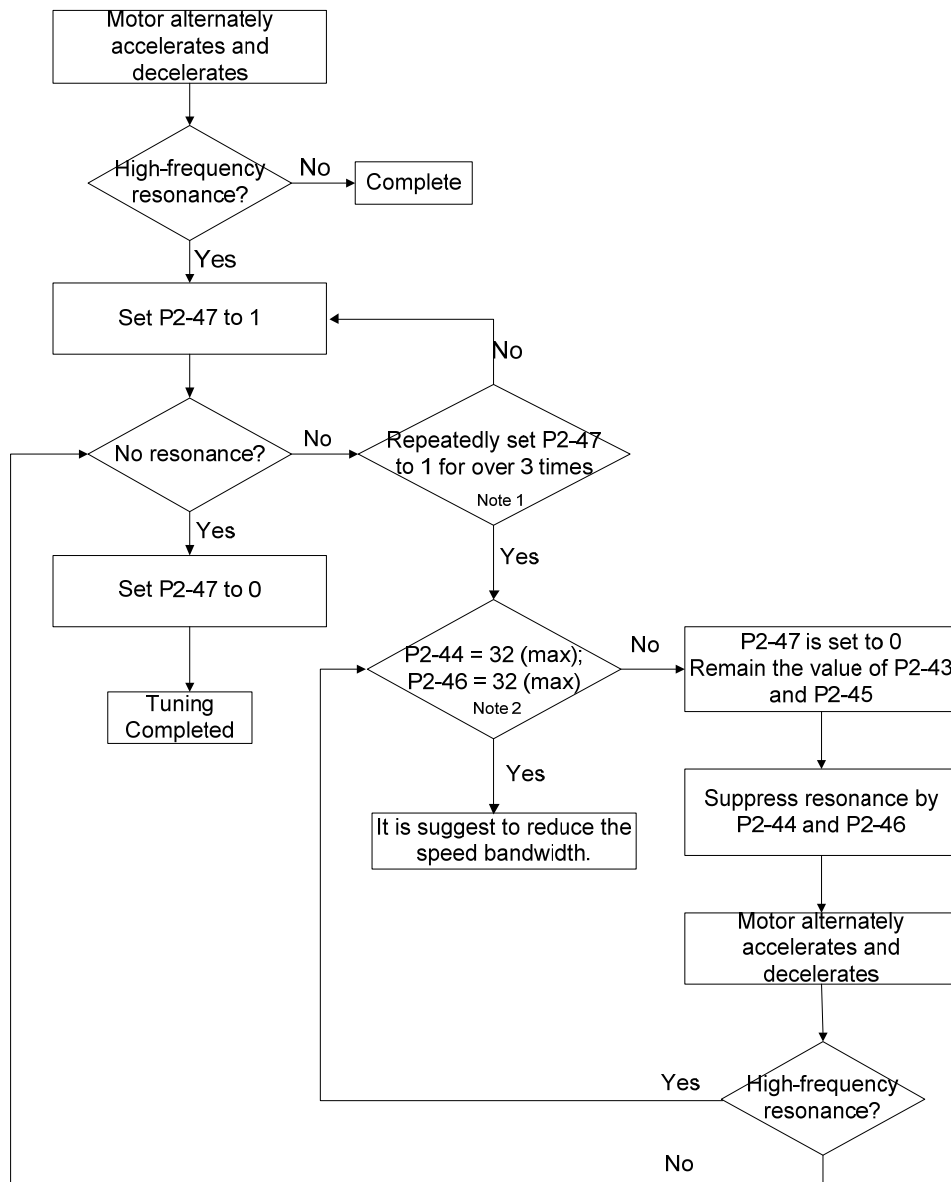

## NOTE

- Parameter P2-44 and P2-46 are the setting value of resonance suppression. If the value has been set to the maximum (32dB), and still cannot suppress the resonance, please reduce the speed bandwidth. After setting P2-47, users can check the value of P2-44 and P2-46. If the value of P2-44 is not 0, it means the resonance frequency exists in the system. Then, users can access P2-43 to see the resonance frequency (Hz). When there is another resonance frequency, the information will be shown in P2-45 and p2-46.
- If resonance still exists, repeatedly set P2-47 to 1 for 3 times and manually adjust the setting of resonance.

### 5.6.6 Mechanical Resonance Suppression Method

Three groups of Notch filter are provided to suppress mechanical resonance. Two of them can be set to the auto resonance suppression and manual adjustment.

The procedure of manually suppress the resonance is as the followings:

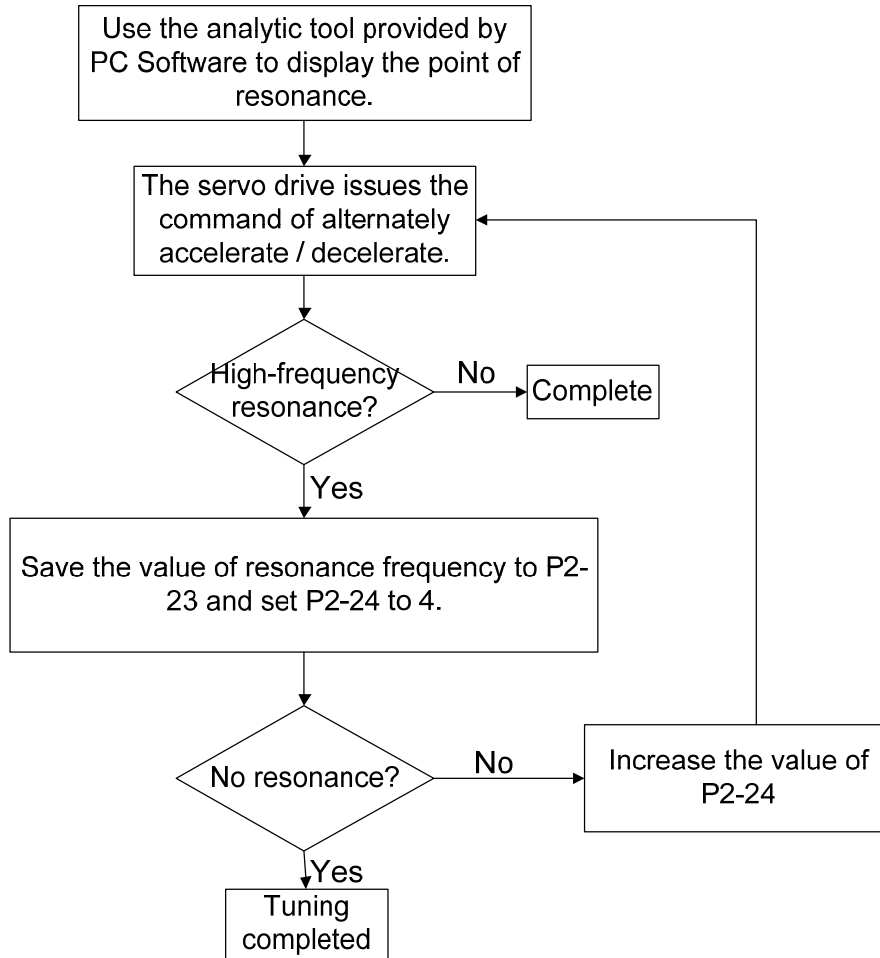

### 5.6.7 Tuning Mode and Parameters

Tuning mode	P2-32	Auto-set parameters	User-defined parameters	Inertia adjustment
Manual mode	0 (default setting)	N/A	P1-37 (Inertia ratio of the motor) P2-00 (Position control gain) P2-04 (Speed control gain) P2-06 (Speed integral compensation) P2-25 (Low-pass filter of resonance suppression) P2-26 (Anti-interference gain)	The value remains
Auto mode (continuous estimation)	1	P1-37 P2-00 P2-04 P2-06 P2-25 P2-26 P2-49	P2-31 Frequency response of speed loop setting in auto mode (response level)	Continuous tuning (update the inertia every 30 minutes)
Semi-auto mode (non-continuous estimation)	2	P1-37 P2-00 P2-04 P2-06 P2-25 P2-26 P2-49	P2-31 Frequency response of speed loop setting in semi-auto mode (response level)	Non-continuous tuning (stop updating the inertia after operating for a while)

When switching mode from auto mode 1 to manual mode 0, the value of P1-37, P2-00, P2-04, P2-06, P2-25, P2-26 and P2-49 will be modified to the one in auto mode.

When switching mode from semi-auto mode 2 to manual mode 0, the value of P1-37, P2-00, P2-04, P2-06, P2-25, P2-26 and P2-49 will be modified to the one in semi-auto mode.



### 5.6.8 Tuning in Manual Mode

The selection of position / speed response frequency should be determined by the machinery stiffness and application. General speaking, the high-frequency machinery or the one requires precise processing needs the higher response frequency. However, it might easily cause the resonance. And the stronger stiffness machinery is needed to avoid the resonance. When using the unknown response frequency machinery, users could gradually increase the gain setting value to increase the response frequency. Then, decrease the gain setting value until the resonance exists. The followings are the related descriptions of gain adjustment.

- Position control gain (KPP, parameter P2-00)

This parameter determines the response of position loop. The bigger KPP value will cause the higher response frequency of position loop. And it will cause better following error, smaller position error, and shorter settling time. However, if the value is set too big, the machinery will vibrate or overshoot when positioning. The calculation of position loop frequency response is as the following:

$$\text{Position Loop Frequency Response (Hz)} = \frac{KPP}{2\pi}$$

- Speed control gain (KVP, parameter P2-04)

This parameter determines the response of speed loop. The bigger KVP value will cause the higher response frequency of speed loop and better following error. However, if the value is set too big, it would easily cause machinery resonance. The response frequency of speed loop must be 4~6 times higher than the response frequency of position loop. Otherwise, the machinery might vibrate or overshoot when positioning. The calculation of speed loop frequency response is as the following:

$$\text{Speed Loop Frequency Response } f_v = \left( \frac{KVP}{2\pi} \right) \times \left[ \frac{(1+P1-37/10)}{(1+JL/JM)} \right] \text{ Hz}$$

JM: Motor Inertia; JL: Load Inertia; P1-37: 0.1 times

When P1-37 (estimation or setting) equals the real inertia ratio (JL/JM), the real speed loop frequency response will be:  $f_v = \frac{KVP}{2\pi} \text{ Hz}$

- Speed integral compensation (KVI, parameter P2-06)

The higher the KVI value is, the better capability of eliminating the deviation will be. However, if the value is set too big, it might easily cause the vibration of machinery. It is suggested to set the value as the following:

$$KVI (P2 - 06) \leq 1.5 \times \text{Speed Loop Frequency Response}$$

- Low-pass filter of resonance suppression (NLP, parameter P2-25)

The high value of inertia ratio will reduce the frequency response of speed loop. Therefore, the KVP value must be increased to maintain the response frequency. During the process of increasing KVP value, it might cause machinery resonance. Please use this parameter to eliminate the noise of resonance. The bigger the value is, the better the capability of improving high-frequency noise will be. However, if the value is set too big, it would cause the instability of speed loop and overshoot. It is suggested to set the value as the following:

$$\text{NLP (P2 - 25)} \leq \frac{1000}{6 \times \text{Speed Loop Frequency Response (Hz)}}$$

- Anti-interference gain (DST, parameter P2-26)

This parameter is used to strengthen the ability of resisting external force and gradually eliminate overshoot during acceleration / deceleration. Its default value is 0. It is suggested not to adjust the value in manual mode, unless it is for fine-tuning.

- Position feed forward gain (PFG, parameter P2-02)

It can reduce the position error and shorten the settling time. However, if the value is set too big, it might cause overshoot. If the setting of e-gear ratio is bigger than 10, it might cause the noise as well.

(This page is intentionally left blank.)

# Chapter 6 Control Mode of Operation

## 6.1 Selection of Operation Mode

Three basic operation modes are provided in this servo drive, position, speed and torque. Users can use single mode (only in one-mode control) and dual mode to control. The following table lists all operation mode and description.

Mode Name	Short Name	Setting Code	Description	
Single Mode	Position mode (Terminal input)	PT	00	The servo drive receives position command and commands the motor to the target position. The position command is input via terminal block and receives pulse signal.
	Position mode (Register input)	PR	01	The servo drive receives position command and commands the motor to the target position. The position command is issued by register (64 sets of register in total) and uses DI signal to select the register.
	Speed Mode	S	02	The servo drive receives speed command and commands the motor to the target speed. The speed command can be issued by register (3 sets of registers in total) or the external analog voltage (-10V ~ +10V). DI signal is used to select the command source.
	Speed mode (No analog input)	Sz	04	The servo drive receives speed command and commands the motor to the target speed. The speed command is issued by register (3 sets of registers in total) and cannot be issued by the external terminal block. DI signal is used to select the command source.
	Torque mode	T	03	The servo drive receives torque command and commands the motor to the target torque. The torque command can be issued by register (3 sets of registers in total) or the external analog voltage (-10V ~ +10V). DI signal is used to select the command source.
	Torque mode (No analog input)	Tz	05	The servo drive receives torque command and commands the motor to the target torque. The torque command can be issued by register (3 sets of registers in total) and cannot be issued by the external terminal block. DI signal is used to select the command source.

Mode Name	Short Name	Setting Code	Description
Dual Mode	PT-S	06	Switch the mode of PT and S via DI signal.
	PT-T	07	Switch the mode of PT and T via DI signal.
	PR-S	08	Switch the mode of PR and S via DI signal.
	PR-T	09	Switch the mode of PR and T via DI signal.
	S-T	0A	Switch the mode of S and T via DI signal.
	CANopen	0B	Control by the master
	Reserved	0C	Reserved
Multi Mode	PT-PR	0D	Switch the mode of PT and PR via DI signal.
	PT-PR-S	0E	Switch the mode of PT, PR and S via DI signal.
	PT-PR-T	0F	Switch the mode of PT, PR and T via DI signal.

The steps of changing mode:

- (1) Switching the servo drive to Servo Off status. Turning SON signal of digit input to be off can complete this action.
- (2) Using parameter P1-01. (Refer to chapter 8).
- (3) After the setting is completed, cut the power off and restart the drive again.

The following sections describe the operation of each control mode, including control structure, command source and loop gain adjustment, etc.

## 6.2 Position Mode

The followings describe the related information and settings of position mode.

### 6.2.1 Position Command in PT Mode

PT, position command is the pulse input from terminal block. There are three types of pulse and each type has positive/negative logic which can be set in parameter P1-00. See as the followings.

P1-00▲	PTT	External Pulse Input Type	Address: 0100H 0101H
	Parameter Attribute :	Parameter for individual axis	Related Section: Section 6.2.1
	Operational Interface :	Panel / Software      Communication	
	Default :	0x2	
	Control Mode :	PT	
	Unit :	-	
	Range :	0 ~ 1132	
	Data Size :	16-bit	
	Format :	Hexadecimal	

Settings :

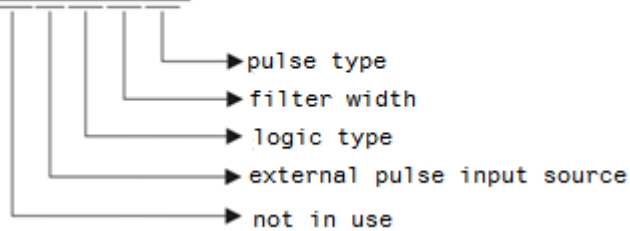

- Pulse Type
  - 0: AB phase pulse (4x)
  - 1: Clockwise (CW) and Counterclockwise (CCW) pulse
  - 2: Pulse + symbol
  - Other settings: reserved

● Filter Width

If the received frequency is much higher than the setting, it will be regarded as the noise and filtered out.

Setting Value	Min. pulse width*note1 (Low-speed filter frequency)	Setting Value	Min. pulse width*note1 (High-speed filter frequency)
0	600 ns (0.83 Mpps)	0	150 ns (3.33 Mpps)
1	2.4 us (208 Kpps)	1	600 ns (0.83 Mpps)
2	4.8 us (104 Kpps)	2	1.2 us (416 Kpps)
3	9.6 us (52 Kpps)	3	2.4 us (208 Kpps)
4	No filter function	4	No filter function



1) When the source of external pulse is from the high-speed differential signal and the setting value is 0 (the high-speed filter frequency is 3.33Mpps at the moment), then:

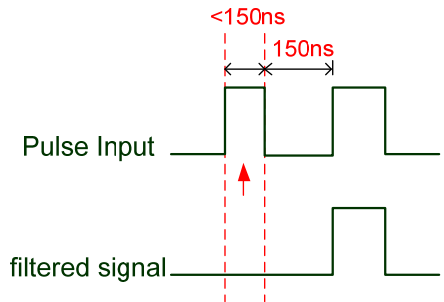

When this pulse width is shorter than 150 ns, it will be seen as low level. Two input pulse will be seen as one.

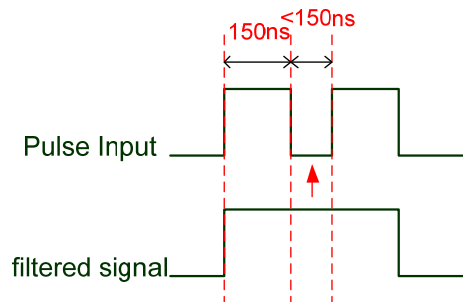

When this pulse width is shorter than 150 ns, it will be seen as high level. Two input pulse will be seen as one.

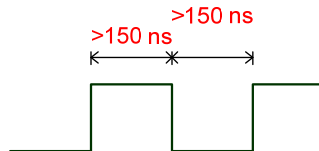

When High, Low duty of the pulse width are longer than 150 ns, it can ensure the pulse command will not be filtered.

If the user uses 2~4MHz input pulse, it is suggested to set the filter value to 4.

Note: When the signal is the high-speed pulse specification of 4 Mpps and the settings value of the filter is 4, then the pulse will not be filtered.

● Logic Type

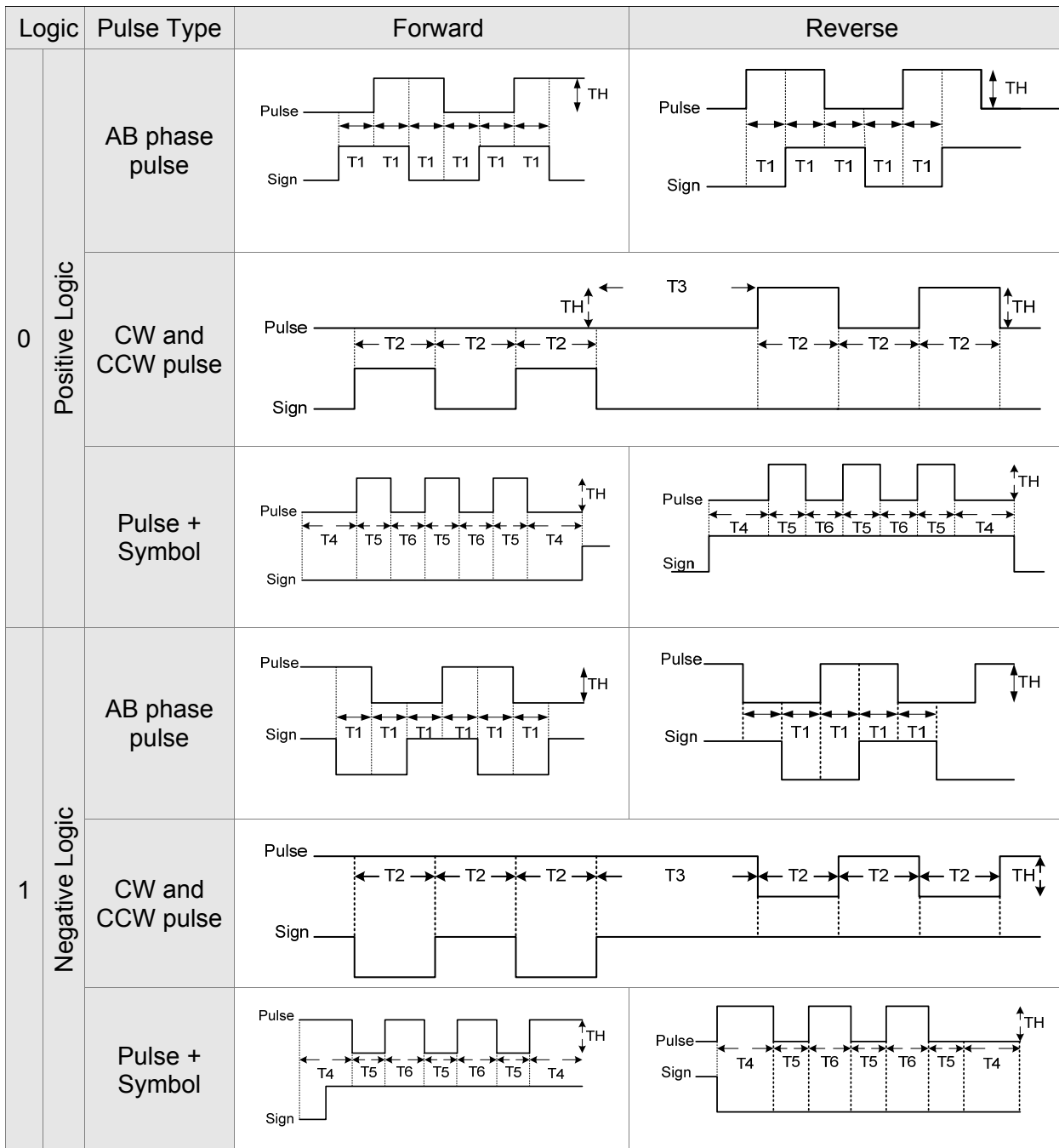

Pulse Specification		Max. Input Frequency	Minimum time width					
			T1	T2	T3	T4	T5	T6
High-speed pulse	Differential Signal	4 Mpps	62.5ns	125ns	250ns	200ns	125ns	125ns
Low-speed pulse	Differential Signal	500 Kpps	0.5µs	1µs	2µs	2µs	1µs	1µs
	Open-collector	200 Kpps	1.25µs	2.5µs	5µs	5µs	2.5µs	2.5µs



Pulse Specification		Max. Input Frequency	Voltage Specification	Forward Current
High-speed pulse	Differential Signal	4 Mpps	5V	< 25 mA
Low-speed pulse	Differential Signal	500 Kpps	2.8V ~ 3.7V	< 25 mA
	Open-collector	200 Kpps	24V (Max.)	< 25 mA

- The Source of External Pulse:  
0: Low-speed optical coupler (CN1 Pin: PULSE, SIGN)  
1: High-speed differential (CN1 Pin: HPULSE, HSIGN)

Position pulse can be input from CN1 terminal, PULSE (43), /PULSE (41), HPULSE (38), /HPULSE (29) and SIGN (36), /SIGN (37), HSIGN (46), /HSIGN (40). It could be open-collector or Line Driver. Please refer to Chapter 3.9.1 for wiring method.

### 6.2.2 Position Command in PR Mode

PR position command source of each axis is from the 64-set of register which constituted by parameters (P6-00, P6-01) ~ (P7-26, P7-27). Through communication, one of the 99-set of register can be used as the position command. When going with the external DI/DO (CN1, POS0 ~POS5 and CTRG), one of the previous 64 sets of register can be selected as the position command. See as the following table:

Position Command	POS5	POS4	POS3	POS2	POS1	POS0	CTRG	Parameters
P1	ON	ON	ON	ON	ON	ON	↑	P6-00
								P6-01
P2	ON	ON	ON	ON	ON	OFF	↑	P6-02
								P6-03
~								~
P50	OFF	OFF	ON	ON	OFF	ON	↑	P6-98
								P6-99
P51	OFF	OFF	ON	ON	OFF	OFF	↑	P7-00
								P7-01
~								~
P64	OFF	OFF	OFF	OFF	OFF	OFF	↑	P7-26
								P7-27

Status of POS0 ~ POS5: 0 means the DI is OFF; 1 means the DI is ON.

CTRG↑: the moment DI is OFF to ON.

The application of absolute type and incremental type register is rather extensive. It is more like a simple procedure control. Users can complete the cyclic operation by referring to the above table. For example, position command P1 is 10 turns and P2 is 20 turns. P1 is issued first and P2 comes after. The following diagram shows the difference of both.

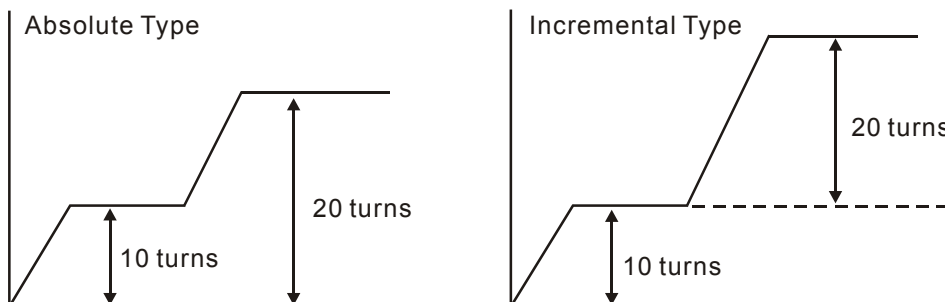

### 6.2.3 Control Structure of Position Mode

The basic control structure is as the following diagram:

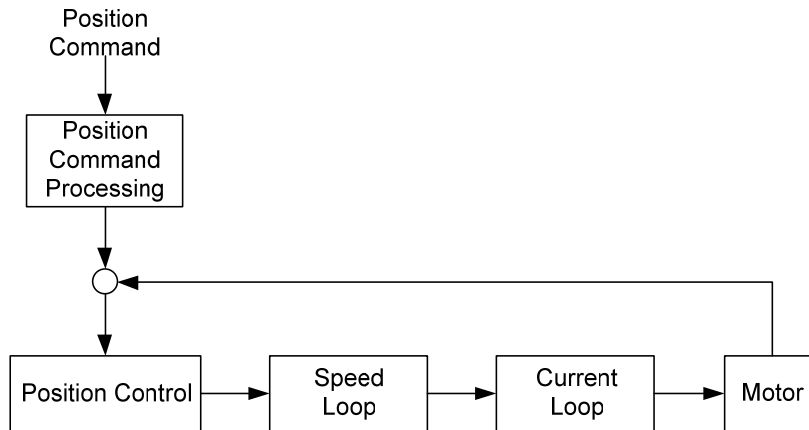

For a better control, the pulse signal should be processed and modified through position command unit. Structure is shown as the diagram below.

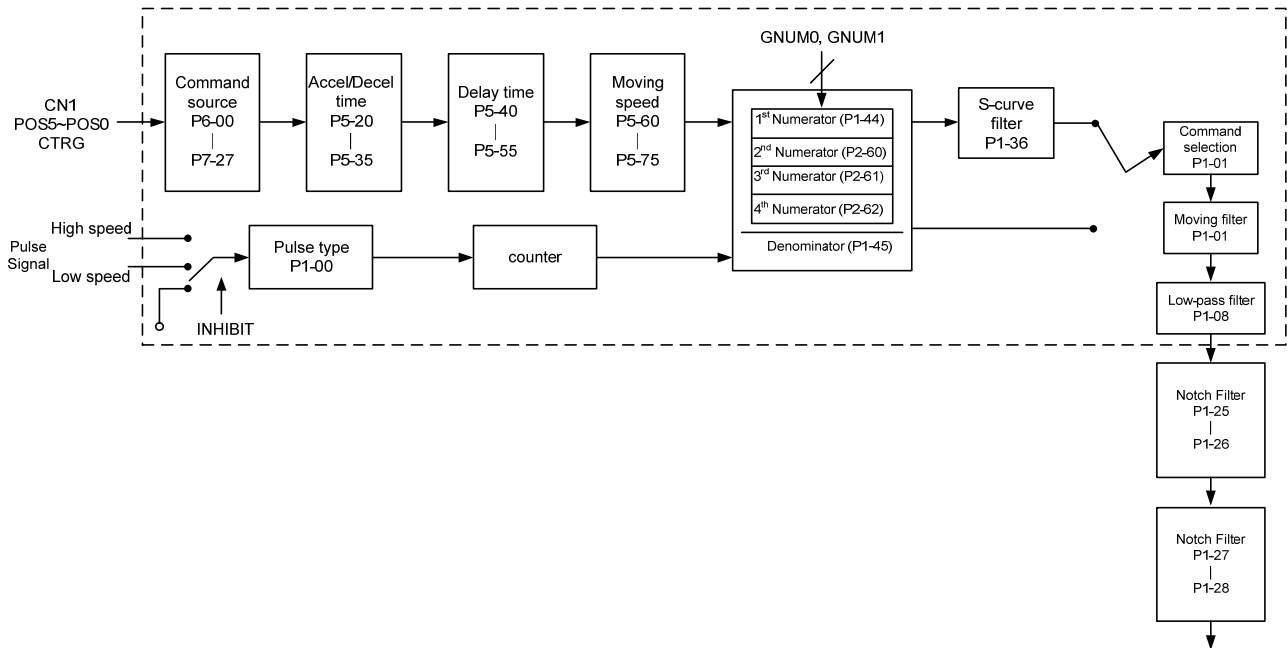

The upper path of the above diagram is PR mode and the lower one is PT mode which could be selected via P1-01. Both modes can set E-gear ratio for the proper position resolution. Moreover, either S-curve filter or low-pass filter can be used to smooth the command. See the description in later parts.

### Pulse Command Inhibit Input Function (INHP)

Use DI to select INHP (Refer to P2-10~17 and table 8.1 INHP (45)) before using this function. If not, this function will be unable to use. When DI (INHP) is ON, the pulse command will be cleared in position control mode and the motor will stop running. (Only DI 8 supports this function.)

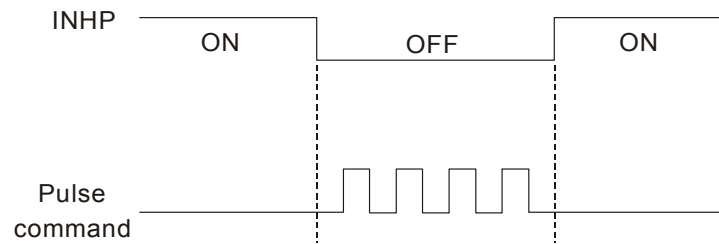

### 6.2.4 S-curve Filter (Position)

S-curve filter smooths the motion command. With S-curve filter, the process of acceleration becomes more continuous and the jerk will be smaller. It not only improves the performance when motor accelerates / decelerates, but also smooths the operation of mechanical structure. When the load inertia increases, the operation of the motor will be influenced by friction and inertia during the time of activation and stop. However, the situation can be improved by increasing the value of Acceleration / Deceleration Constant of S-Curve (TSL), Acceleration Constant of S-Curve (TACC) and Deceleration Constant of S-Curve (TDEC). When the position command source is pulse, its speed and angular acceleration is continuous, thus, S-curve filter is not a must.

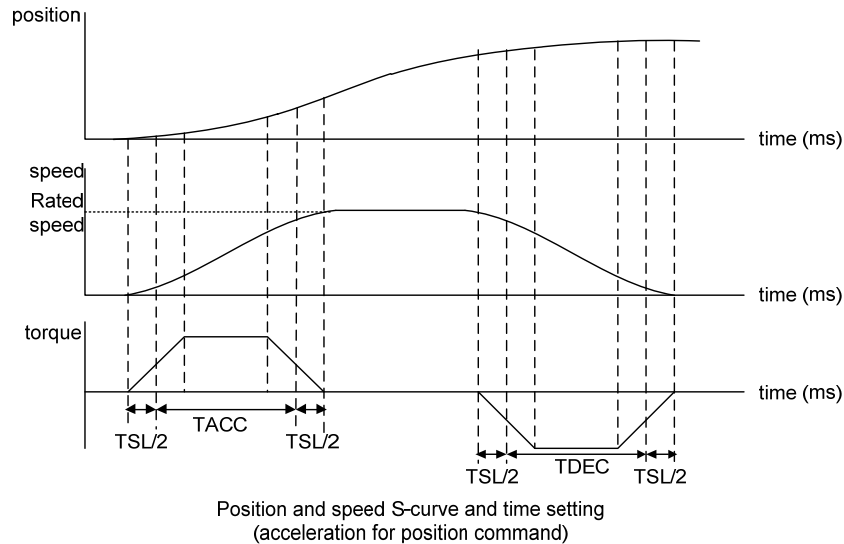

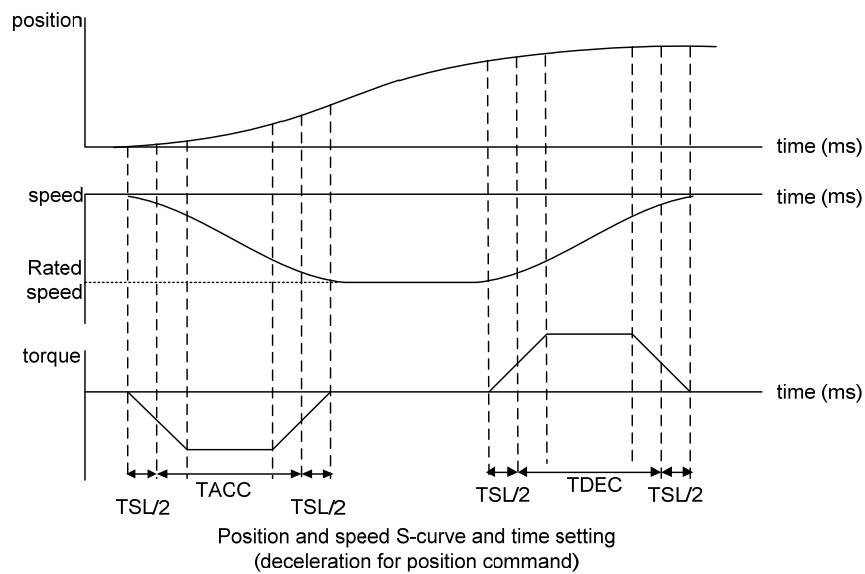

Relevant Parameters:

<b>P1-34</b>	<b>TACC</b>	<b>Acceleration Constant of S-Curve</b>	<b>Address: 0144H 0145H</b>
Operational Interface :		Panel / Software	Related Section: 6.3.3
		Communication	
Default :		200	
Control Mode :		S	
Unit :		ms	
Range :		1 ~ 65500	
Data Size :		16-bit	
Format :		Decimal	

Settings : Acceleration Constant of Rotary Motor:  
The time that speed command accelerates from 0 to the rated speed.  
Acceleration Constant of Linear Motor  
The time that speed command accelerates from 0 to 5m/s.  
P1-34, P1-35 and P1-36, the acceleration time of speed command from zero to the rated speed, all can be set individually. Even when P1-36 is set to 0, it still has acceleration / deceleration of trapezoid-curve.



**NOTE**

- 1 ) When the source of speed command is analog, and P1-36 is set to 0, it will disable S-curve function.
- 2 ) When the source of speed command is analog, the max. range of P1-34 will be set within 20000 automatically.

P1-35	TDEC	Deceleration Constant of S-Curve	Address: 0146H 0147H
Operational Interface :	Panel / Software	Communication	Related Section: 6.3.3
Default :	200		
Control Mode :	S		
Unit :	ms		
Range :	1 ~ 65500		
Data Size :	16-bit		
Format :	Decimal		
Settings :	Deceleration Constant of Rotary Motor: The time that speed command decelerates from the rated speed to 0. Deceleration Constant of Linear Motor: The time that speed command decelerates from 5m/s to 0. P1-34, P1-35 and P1-36, the deceleration time of speed command from the rated speed to zero, all can be set individually. Even when P1-36 is set to 0, it still has acceleration / deceleration of trapezoid-curve.		

**NOTE**

- 1 ) When the source of speed command is analog, and P1-36 is set to 0, it will disable S-curve function.
- 2 ) When the source of speed command is analog, the max. range of P1-35 will be set within 20000 automatically.

P1-36	TSL	Acceleration / Deceleration Constant of S-Curve	Address: 0148H 0149H
Operational Interface :	Panel / Software	Communication	Related Section: 6.3.3
Default :	0		
Control Mode :	S, PR		
Unit :	ms		
Range :	0 ~ 65500 (0: disable this function)		
Data Size :	16-bit		
Format :	Decimal		

Settings : Acceleration / Deceleration Constant of S-Curve:

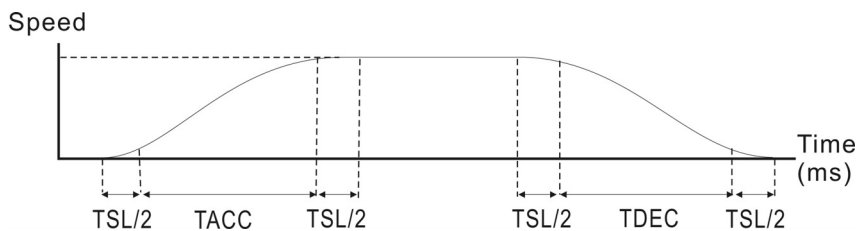

P1-34: Set the acceleration time of acceleration / deceleration of trapezoid-curve

P1-35: Set the deceleration time of acceleration / deceleration of trapezoid-curve

P1-36: Set the smoothing time of S-curve acceleration and deceleration

P1-34, P1-35 and P1-36 can be set individually. Even when P1-36 is set to 0, it still has acceleration / deceleration of trapezoid-curve.



**NOTE**

- 1) When the source of speed command is analog, and P1-36 is set to 0, it will disable S-curve function.
- 2) When the source of speed command is analog, the max. range of P1-36 will be set within 10000 automatically.

### 6.2.5 Electronic Gear Ratio

Related parameters:

<b>P1-44 ▲</b>	<b>GR1</b>	<b>Gear Ratio (Numerator) (N1)</b>	<b>Address: 0158H 0159H</b>
Operational Interface :	Panel / Software	Communication	Related Section: 6.2.5
Default :	1		
Control Mode :	PT / PR		
Unit :	Pulse		
Range :	1 ~ (2 <sup>29</sup> -1)		
Data Size :	32-bit		
Format :	Decimal		

Settings : Please refer to P2-60~P2-62 for the setting of multiple gear ratio (numerator).



**NOTE**

1. In PT mode, the setting value can be changed when Servo ON.
2. In PR mode, the setting value can be changed when Servo OFF.

<b>P1-45</b>	<b>GR2</b>	<b>Gear Ratio (Denominator) (M)</b>	<b>Address: 015AH 015BH</b>
	Operational Interface :	Panel / Software	Communication
	Default :	1	
	Control Mode :	PT / PR	
	Unit :	Pulse	
	Range :	1 ~ (2 <sup>31</sup> -1)	
	Data Size :	32-bit	
	Format :	Decimal	

Related Section: 6.2.5

Settings : If the setting is wrong, the servo motor will easily have sudden unintended acceleration.

Please follow the rules for setting:

The setting of pulse input:

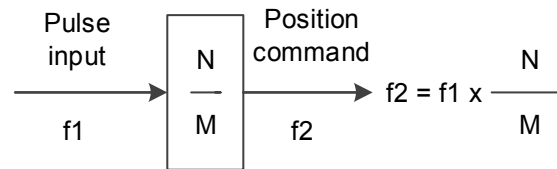

Range of command pulse input:  $1 / 50 < N \times / M < 25600$



**NOTE**

1) The setting value cannot be changed when Servo ON neither in PT nor in PR mode.

E-Gear ratio =  $\frac{N}{M} = \frac{P1-44}{P1-45}$ , has to match  $\frac{1}{50} \leq \left(\frac{N}{M}\right) \leq 5000$

Electronic gear provides simple ratio change of travel distance. The high electronic gear ratio would cause the position command to be the stepped command. S-curve or low-pass filter can be used to improve the situation. When electronic gear ratio is set to 1, the motor will turn one cycle for every 10000PUU. When electronic gear ratio is changed to 0.5, then every two pulses from the command will be refer to one PUU of motor encoder.



For example (rotary motor): after setting the electronic gear ratio properly, the moving distance of the object is 1µm/pulse, which is easier to use.

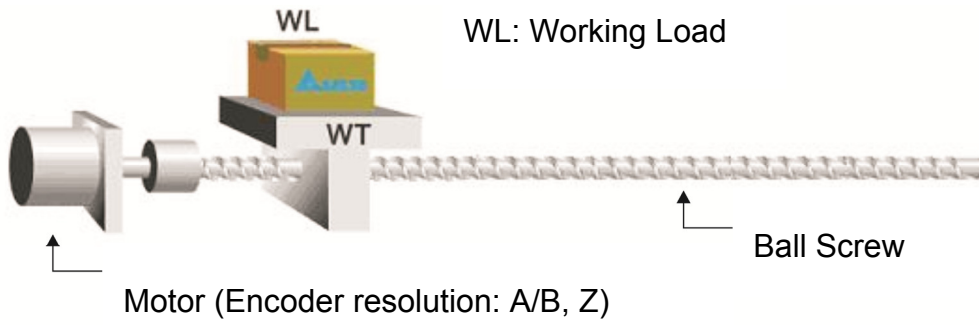

	Gear Ratio	Moving distance of each pulse command
Electronic gear is unapplied.	$\frac{1}{1}$	$= \frac{3 \times 1000}{4 \times 2500} = \frac{3000}{10000} = \mu m$
Electronic gear is applied.	$= \frac{10000}{3000}$	$= 1\mu m$

### 6.2.6 Low-pass Filter

Related parameters:

<b>P1-08</b>	<b>PFLT</b>	<b>Smooth Constant of Position Command (Low-pass Filter)</b>	<b>Address: 0110H 0111H</b>
	Operational Interface :	Panel / Software	Communication
	Default :	0	
	Control Mode :	PT / PR	
	Unit :	10 ms	
	Range :	0 ~ 1000	
	Data Size :	16-bit	
	Format :	Decimal	
	Example :	11 = 110 ms	
	Settings :	0: Disabled	

Related Section:  
6.2.6

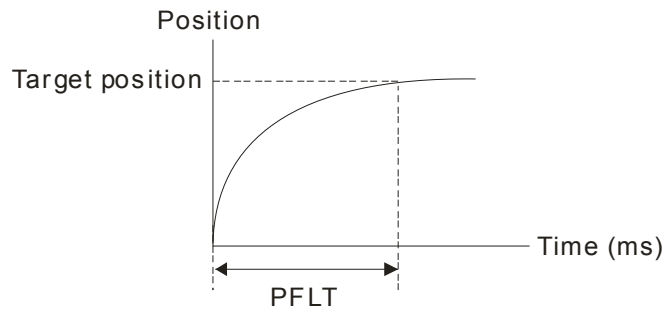

### 6.2.7 Timing Diagram in Position Mode (PR)

In PR mode, the position command is selected by either DI signal (POS0~POS5 and CTRG) of CN1 or communication. Please refer to Section 6.2.2 for the information about DI signal and its selected register. Followings are the timing diagrams.

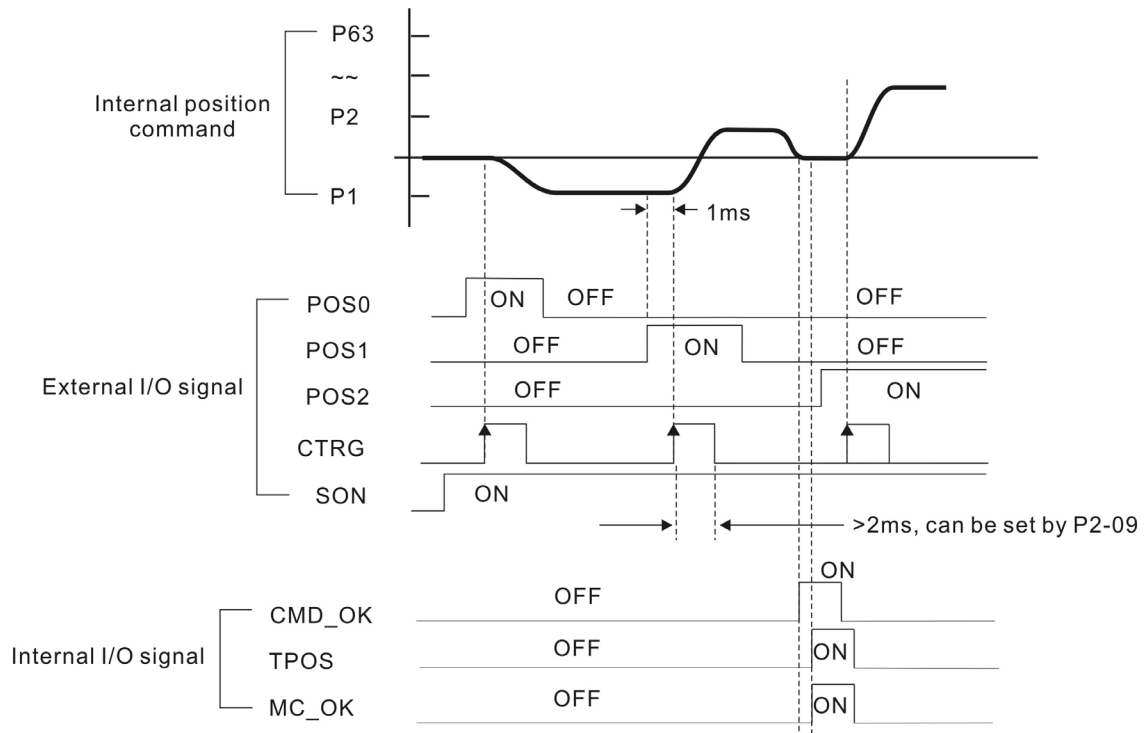

**CMD\_OK :** CMD\_OK is activated when the servo drive has detected that Pr command has been completed

**TPOS :** TPOS will be activated when the drive detects that the position of the motor is in a -P1-54 to +P1-54 band of the target position.

**MC\_OK :** MC\_OK is activated when CMD\_OK and TPOS are both ON.

## 6.2.8 Gain Adjustment of Position Loop

Before setting the position control unit, users have to manually (P2-32) complete the setting of speed control unit since the speed loop is included in position loop. Then, set the proportional gain (parameter P2-00) and feed forward gain (parameter P2-02) of position loop. Users also can use the auto mode to set the gain of speed and position control unit automatically.

- 1) Proportional gain: Increase the gain so as to enhance the response bandwidth of position loop.
- 2) Feed forward gain: Minimize the deviation of phase delay

The position loop bandwidth cannot exceed the speed loop bandwidth. It is suggested that  $f_p \leq \frac{f_v}{4}$ .

$f_v$ : response bandwidth of speed loop (Hz).

$KPP = 2 \times \pi \times f_p$ .  $f_p$ : response bandwidth of position loop (Hz).

For example, the desired position bandwidth is 20 Hz  $\rightarrow KPP = 2 \times \pi \times 20 = 125$ .

Related parameters:

P2-00	KPP	Position Loop Gain	Address: 0200H 0201H
	Operational Interface :	Panel / Software      Communication	Related Section: 6.2.8
	Default :	35	
	Control Mode :	PT / PR	
	Unit :	rad/s	
	Range :	0 ~ 2047	
	Data Size :	16-bit	
	Format :	Decimal	
	Settings :	When the value of position loop gain is increased, the position response can be enhanced and the position error can be reduced. If the value is set too big, it may easily cause vibration and noise.	

P2-02	PFG	Position Feed Forward Gain	Address: 0204H 0205H
	Operational Interface :	Panel / Software      Communication	Related Section: 6.2.8
	Default :	50	
	Control Mode :	PT / PR	
	Unit :	%	

Range :	0 ~ 100
Data Size :	16-bit
Format :	Decimal

Settings : If the position command is changed smoothly, increasing the gain value can reduce the position error.  
 If the position command is not changed smoothly, decreasing the gain value can tackle the problem of mechanical vibration.

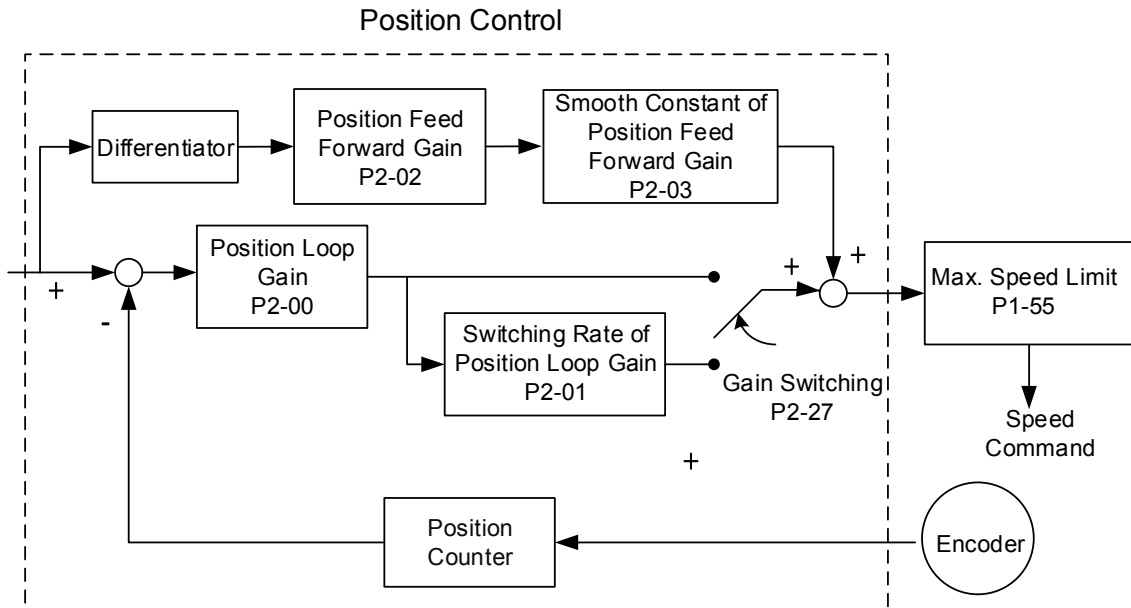

When the value of proportional gain, KPP is set too big, the response bandwidth of position loop will be increased and diminish the phase margin. And the motor rotor rotates vibrantly in forward and reverse direction at the moment. Thus, KPP has to be decreased until the rotor stops vibrating. When the external torque interrupts, the over-low KPP cannot meet the demand of position deviation. In this situation, parameter P2-02 can effectively reduce the position error.

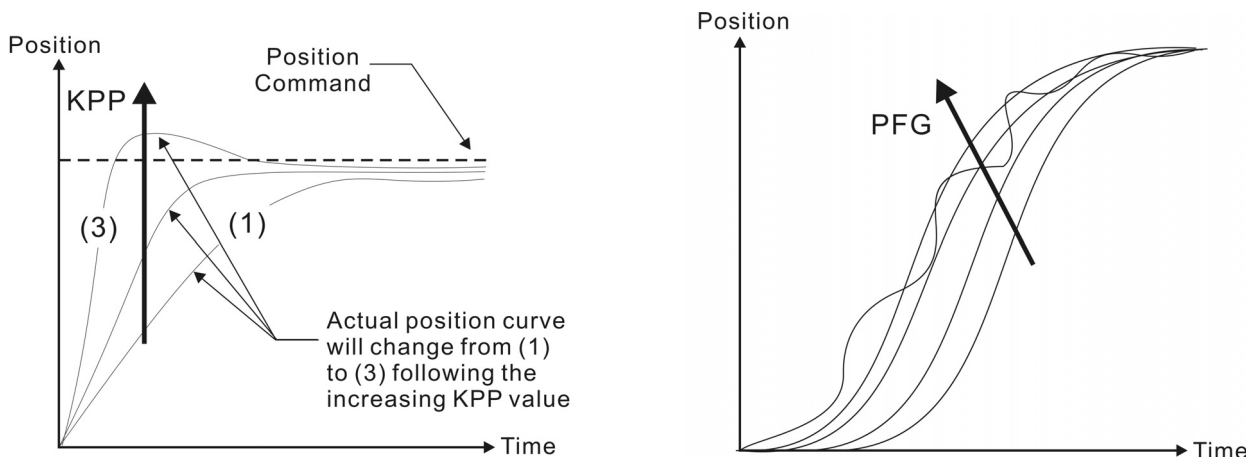

### 6.2.9 Low-frequency Vibration Suppression in Position Mode

If the stiffness is not enough, the mechanical transmission will continue to vibrate even when the motor stops after completing the positioning command. The function of low-frequency vibration suppression can eliminate the vibration of mechanical transmission. The range is between 1.0Hz and 100.0HZ. Both manual setting and auto setting are provided.

Auto setting:

If the frequency is hard to find, it can enable the function of auto low-frequency vibration suppression. This function automatically searches the frequency of low-frequency vibration. If P1-29 is set to 1, the system will disable the function of low-frequency vibration suppression automatically and starts to search the vibration frequency. When the detected frequency remains at the same level, P1-29 will be set to 0 automatically and set the first frequency in P1-25 and set P1-26 to 1. The second frequency will be set in P1-27 and then set P1-28 to 1. If P1-29 is automatically set back to 0 and still has low-frequency vibration, please check if the function of P1-26 or P1-28 is enabled. If the value of P1-26 and P1-28 is 0, it means no frequency has been detected. Please decrease the value of P1-30 and set P1-29 to 1 so as to search the vibration frequency again. Please note that when the detection level is set too small, the noise will be regarded as the low-frequency.

Flowchart of auto low-frequency vibration suppression:

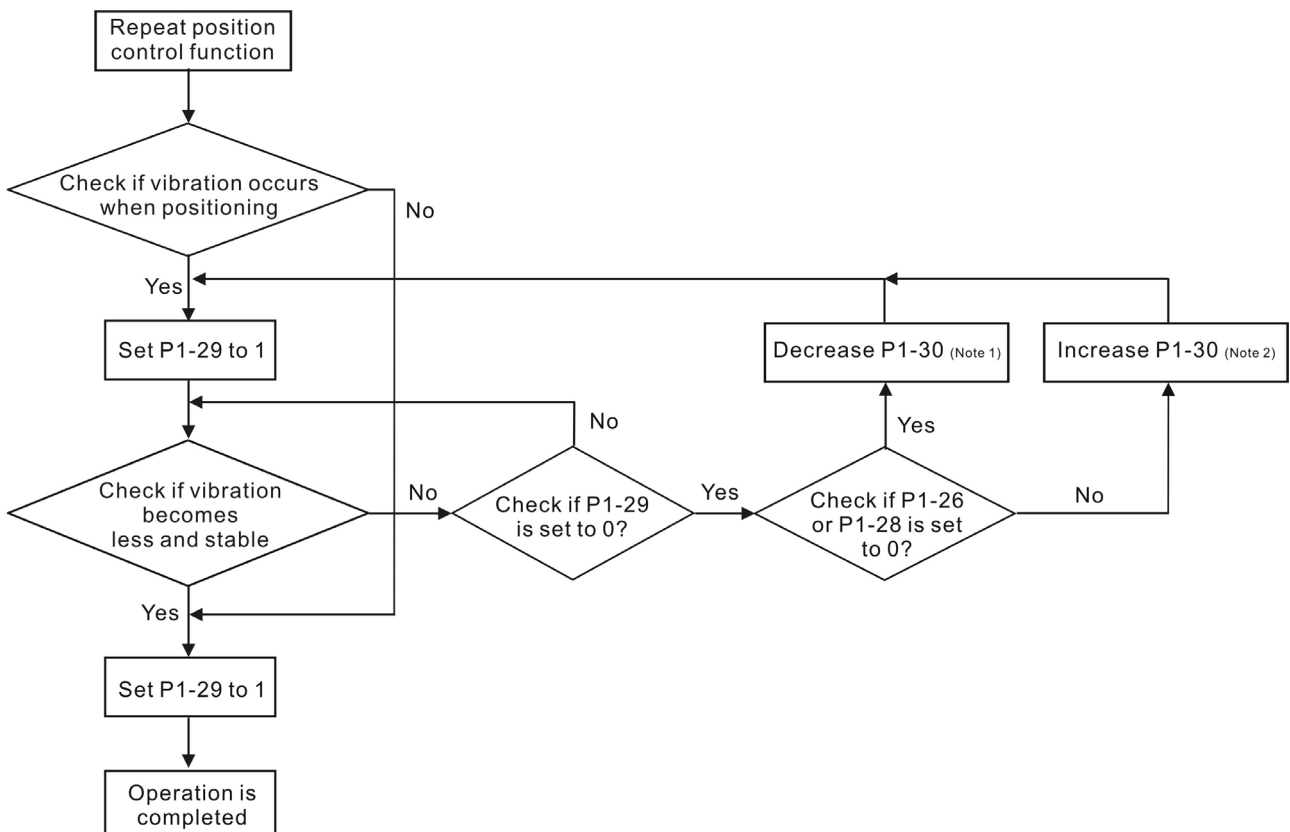

Note 1: When the value of P1-26 and P1-28 is 0, it means it is unable to search the frequency. It is probably because the detection level is set too high and is unable to detect the low-frequency vibration.

Note 2: When the value of P1-26 or P1-28 is not set to 0 and still cannot eliminate the vibration, it is probably because the detection level is set too low, the system regards the noise or other non-primary frequency as the low-frequency vibration.

Note 3: When the process of auto vibration suppression is completed and the vibration still cannot be diminished, P1-25 or P1-27 can be manually set to suppress the vibration if the frequency (Hz) of the low-frequency is identified.

Related parameters:

P1-29	AVSM	Auto Low-frequency Vibration Supression Setting	Address: 013AH 013BH
Operational Interface :		Panel / Software	Communication
Default :		0	
Control Mode :		PT / PR	
Unit :		-	
Range :		0 ~ 1	
Data Size :		16-bit	
Format :		Decimal	
Settings :			
0: The function is disabled.			
1: The value will set back to 0 after vibration suppression.			
Description of Auto Mode Setting:			
When the parameter is set to 1, it is in auto suppression. When the vibration frequency is not being detected or the value of searched frequency is stable, the parameter will set to 0 and save the low-frequency vibration suppression to P1-25 automatically.			

P1-30	VCL	Low-frequency Vibration Detection	Address: 013CH 013DH
Operational Interface :		Panel / Software	Communication
Default :		500	
Control Mode :		PT / PR	

Unit :	Pulse
Range :	1 ~ 8000
Data Size :	16-bit
Format :	Decimal

Settings : When enabling the auto suppression (P1-29 = 1), it will automatically search the detection level. The lower the value is, the more sensitive the detection will be. However, it is easy to misjudge the noise or regard the other low-frequency vibration as the suppression frequency. If the value is bigger, it will make more precise judgment. However, if the vibration of the mechanism is smaller, it might not detect the frequency of low-frequency vibration.

P1-30 is to set the range to detect the magnitude of low-frequency vibration. When the frequency is not being detected, it is probably because the value of P1-30 is set too big which exceeds the range of vibration. It is suggested to decrease the value of P1-30. Please note that if the value is too small, the system might regard the noise as the vibration frequency. If the SCOPE is available, it can be used to observe the range of position error (pulse) between upper and lower magnitude of the curve and set up the appropriate value of P1-30.

#### Manual Setting:

There are two sets of low-frequency vibration suppression. One is parameter P1-25~P1-26 and another one is parameter P1-27~P1-28. These two sets of low-frequency vibration suppression can be used to eliminate two different frequency vibrations. Parameter P1-25 and P1-27 are used to suppress the low-frequency vibration. The function is working only when the parameter setting value of low-frequency vibration close to the real vibration frequency. Parameter P1-26 and P1-28 are used to set the response after filter. The bigger the setting value of P1-26 and P1-28 is, the better response will be. However, if the value is set too big, the motor might not operate smoothly. The default value of parameter P1-26 and P1-28 is 0, which means the function is disabled. Followings are the related parameters:

P1-25	VSF1	Low-frequency Vibration Suppression (1)	Address: 0132H 0133H
Operational Interface :	Panel / Software	Communication	Related Section: 6.2.9
Default :	1000		
Control Mode :	PT / PR		



Unit :	0.1 Hz
Range :	10 ~ 1000
Data Size :	16-bit
Format :	Decimal
Example :	150= 15 Hz

Settings : The setting value of the first low-frequency vibration suppression. If P1-26 is set to 0, then it will disable the first low-frequency filter.

<b>P1-26</b>	<b>VSG1</b>	<b>Low-frequency Vibration Suppression Gain (1)</b>	<b>Address: 0134H 0135H</b>
--------------	-------------	---	---------------------------------

Operational Interface :	Panel / Software	Communication	Related Section: 6.2.9
-------------------------	------------------	---------------	---------------------------

Default : 0

Control Mode : PT / PR

Unit : -

Range : 0 ~ 9 (0: Disable the first low-frequency filter)

Data Size : 16-bit

Format : Decimal

Settings : The first low-frequency vibration suppression gain. The bigger value it is, the better the position response will be. However, if the value is set too big, the motor will not be able to smoothly operate. It is suggested to set the value to 1.

<b>P1-27</b>	<b>VSF2</b>	<b>Low-frequency Vibration Suppression (2)</b>	<b>Address: 0136H 0137H</b>
--------------	-------------	--	---------------------------------

Operational Interface :	Panel / Software	Communication	Related Section: 6.2.9
-------------------------	------------------	---------------	---------------------------

Default : 1000

Control Mode : PT / PR

Unit : 0.1 Hz

Range : 10 ~ 1000

Data Size : 16-bit

Format : Decimal

Example : 150 = 15 Hz

Settings : The setting value of the second low-frequency vibration suppression. If P1-28 is set to 0, then it will disable the second low-frequency filter.

P1-28	VSG2	Low-frequency Vibration Suppression Gain (2)	Address: 0138H 0139H
Operational Interface :	Panel / Software	Communication	Related Section: 6.2.9
Default :	0		
Control Mode :	PT / PR		
Unit :	-		
Range :	0 ~ 9 (0: Disable the second low-frequency filter)		
Data Size :	16-bit		
Format :	Decimal		

Settings : The second low-frequency vibration suppression gain. The bigger value it is, the better the position response will be. However, if the value is set too big, the motor will not be able to smoothly operate. It is suggested to set the value to 1.

## 6.3 Speed Mode

Speed control mode (S or Sz) is applicable in precision speed control, such as CNC machine tools. This servo drive includes two types of command input, analog and register. Analog command input can use external voltage to control the motor speed. There are two methods in register input. One is used before operation. Users set different value of speed command in three registers, and then use SP0, SP1 of CN1 DI signal for switching. Another method is to change the value of register by communication. In order to deal with the problem of non-continuous speed command when switching register, a complete S-curve program is provided. In close-loop system, this servo drive adopts gain adjustment and integrated PI controller and two modes (manual and auto) for selection. Users can set all parameters and all auto or auxiliary function will be disabled in manual mode. While in auto mode, it provides the function of load inertia estimation and parameter adjustment. In auto mode, parameters which set by users will be regarded as the default value.

### 6.3.1 Selection of Speed Mode

There are two types of speed command source, analog voltage and internal parameters. The selection is determined by CN1 DI signal. See as the followings.

Speed Command	CN1 DI signal		Command Source		Content	Range
	SPD1	SPD0				
S1	0	0	Mode	S	External analog signal	Voltage between V-REF-GND -10 V ~ +10V
				Sz	N/A	Speed command is 0 0
S2	0	1	Register parameters		P1-09	-60000 ~ 60000
S3	1	0			P1-10	
S4	1	1			P1-11	

- Status of SPD0 ~ SPD1: 0 means DI OFF, 1 means DI ON.
- When both SPD0 and SPD1 are 0, if it is in Sz mode, the command will be 0. Thus, if there is no need to use analog voltage as the speed command, Sz mode can be applied to tackle the problem of zero-drift. If it is in S mode, the command will be the voltage deviation between V-REF and GND. The range of input voltage is between -10V and +10V and its corresponding speed is adjustable (P1-40).
- When one of SPD0 and SPD1 is not 0, the speed command is from the internal parameter. The command is activated after changing the status of SPD0~SPD1. There is no need to use CTRG for triggering.

- The setting range of internal parameters is between -60000 and 60000. Setting value = setting range x unit (0.1r/min).

For example: P1-09 = +30000, setting value = +30000 x 0.1r/min = +3000r/min

The speed command not only can be issued in speed mode (S or Sz), but also in torque mode (T or Tz) as the speed limit.

### 6.3.2 Control Structure of Speed Mode

The basic control structure is shown as the following diagram:

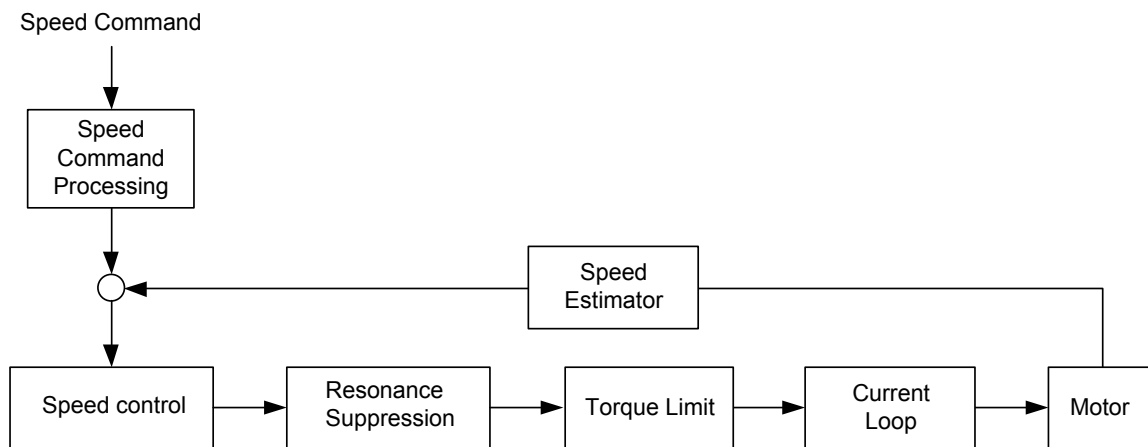

The speed command unit is to select speed command source according to Section 6.3.1, including the scaling (P1-40) setting and S-curve setting. The speed control unit manages the gain parameters of the servo drive and calculates the current command for servo motor in time. The resonance suppression unit is to suppress the resonance of mechanism. Detailed descriptions are shown as the following:

Here firstly introduces the function of speed command unit. Its structure is as the following diagram.

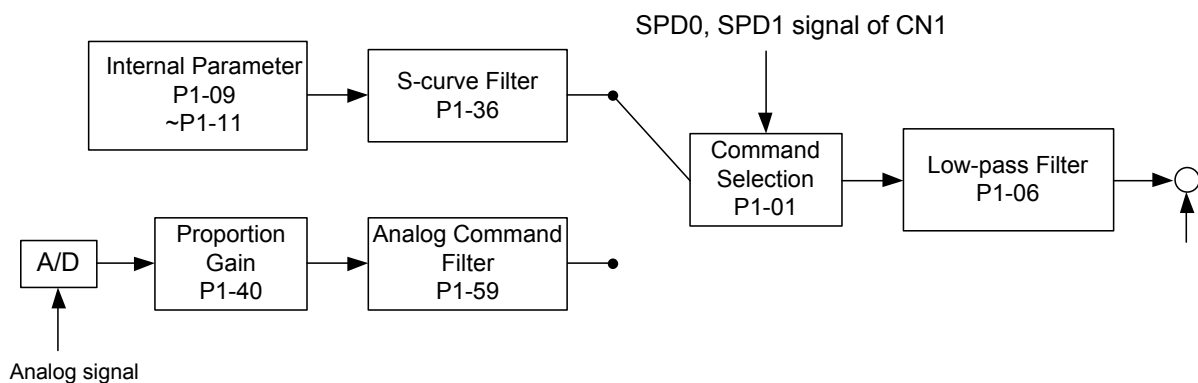

The upper path is the command from register while the lower one is external analog command. The command is selected according to the status of SPD0, SPD1 and P1-01(S or Sz). Usually, S-curve and low-pass filter are applied for having a smooth resonance of command.

### 6.3.3 Smooth Speed Command

#### S-curve Filter

During the process of acceleration or deceleration, S-curve filter applies the program of three-stage acceleration curve for smoothing the motion command, which generates the continuous acceleration. It is for avoiding the jerk (the differentiation of acceleration) came from the sudden command change and indirectly causes the resonance and noise. Users can use acceleration constant of S-curve (TACC) to adjust the slope changed by acceleration, deceleration constant of S-curve (TDEC) to adjust the slope changed by deceleration and acceleration / deceleration constant of S-curve (TSL) to improve the status of motor activation and stop. The calculation of the time to complete the command is provided.

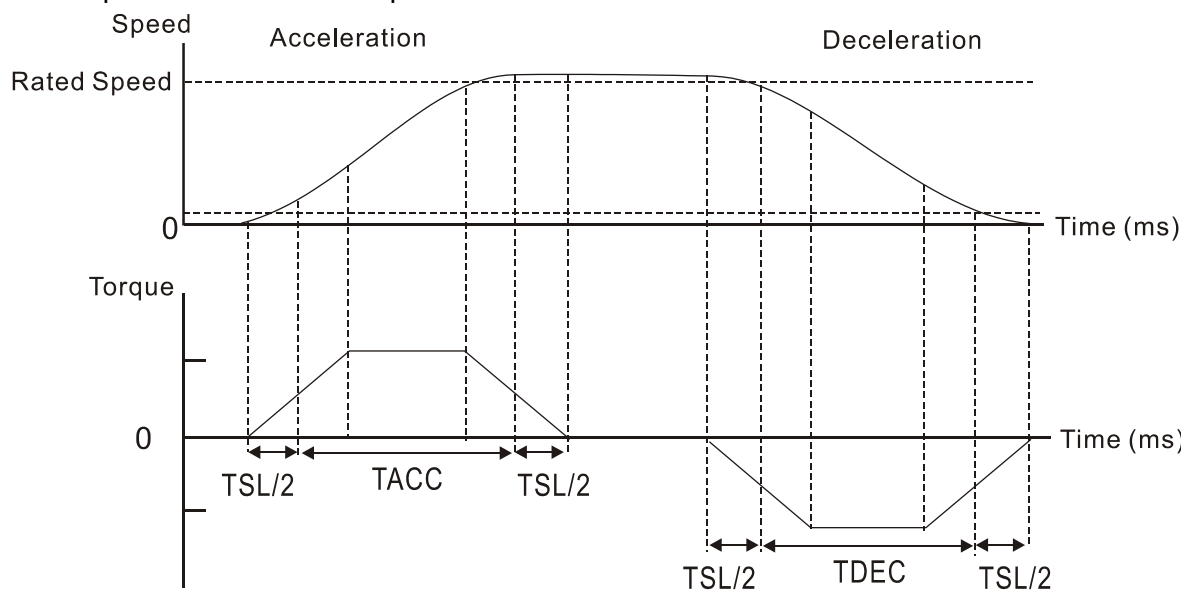

S-curve characteristics and Time relationship

Related parameters:

P1-34	TACC	Acceleration Constant of S-Curve	Address: 0144H 0145H
Operational Interface :	Panel / Software	Communication	Related Section: 6.3.3
Default :	200		
Control Mode :	S		
Unit :	ms		
Range :	1 ~ 65500		
Data Size :	16-bit		
Format :	Decimal		

Settings : Acceleration Constant of Rotary Motor:

The time that speed command accelerates from 0 to the rated speed.

Acceleration Constant of Linear Motor

The time that speed command accelerates from 0 to 5m/s.

P1-34, P1-35 and P1-36, the acceleration time of speed command from zero to the rated speed, all can be set individually. Even when P1-36 is set to 0, it still has acceleration / deceleration of trapezoid-curve.



**NOTE**

- 1 ) When the source of speed command is analog, and P1-36 is set to 0, it will disable S-curve function.
- 2 ) When the source of speed command is analog, the max. range of P1-34 will be set within 20000 automatically.

P1-35	TDEC	Deceleration Constant of S-Curve	Address: 0146H 0147H
Operational Interface :	Panel / Software	Communication	Related Section: 6.3.3
Default :	200		
Control Mode :	S		
Unit :	ms		
Range :	1 ~ 65500		
Data Size :	16-bit		
Format :	Decimal		

Settings : Deceleration Constant of Rotary Motor:

The time that speed command decelerates from the rated speed to 0.

Deceleration Constant of Linear Motor:

The time that speed command decelerates from 5m/s to 0.

P1-34, P1-35 and P1-36, the deceleration time of speed command from the rated speed to zero, all can be set individually. Even when P1-36 is set to 0, it still has acceleration / deceleration of trapezoid-curve.



**NOTE**

- 1 ) When the source of speed command is analog, and P1-36 is set to 0, it will disable S-curve function.
- 2 ) When the source of speed command is analog, the max. range of P1-35 will be set within 20000 automatically.

<b>P1-36</b>	<b>TSL</b>	<b>Acceleration / Deceleration Constant of S-Curve</b>	<b>Address: 0148H 0149H</b>
	Operational Interface :	Panel / Software      Communication	Related Section: 6.3.3
	Default :	0	
	Control Mode :	S, PR	
	Unit :	ms	
	Range :	0 ~ 65500 (0: disable this function)	
	Data Size :	16-bit	
	Format :	Decimal	

Settings : Acceleration / Deceleration Constant of S-Curve:  
Speed

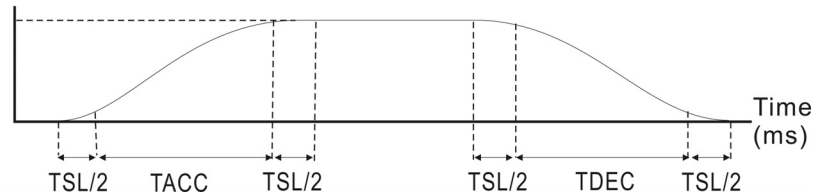

P1-34: Set the acceleration time of acceleration / deceleration of trapezoid-curve

P1-35: Set the deceleration time of acceleration / deceleration of trapezoid-curve

P1-36: Set the smoothing time of S-curve acceleration and deceleration

P1-34, P1-35 and P1-36 can be set individually. Even when P1-36 is set to 0, it still has acceleration / deceleration of trapezoid-curve.



**NOTE** 1) When the source of speed command is analog, and P1-36 is set to 0, it will disable S-curve function.

2) When the source of speed command is analog, the max. range of P1-36 will be set within 10000 automatically.

### Analog Speed Command Filter

Analog speed command filter is provided especially for ASDA-A2 series users. It mainly helps with buffer when the analog input signal changes too fast.

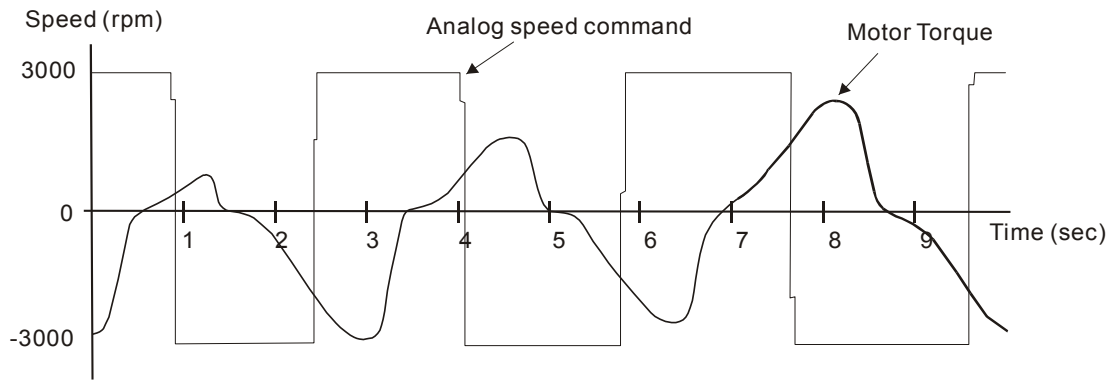

Analog speed command filter smooth the analog input command. Its time program is the same as S-curve filter in normal speed. Also, the speed curve and the acceleration curve are both continuous. The above is the diagram of analog speed command filter. The slope of speed command in acceleration and deceleration is different. Users could adjust the time setting (P1-34, P1-35 and P1-36) according to the actual situation to improve the performance.

**Command End Low-pass Filter**

It is usually used to eliminate the unwanted high-frequency response or noise. It also can smooth the command.

Related parameters:

P1-06	SFLT	Analog Speed Command (Low-pass Filter)	Address: 010CH 010DH
Operational Interface :	Panel / Software	Communication	Related Section: 6.3.3
Default :	0		
Control Mode :	S		
Unit :	ms		
Range :	0 ~ 1000 (0: disable this function)		
Data Size :	16-bit		
Format :	Decimal		
Settings :	0: Disabled		

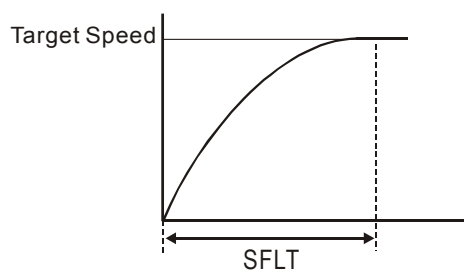



### 6.3.4 The Scaling of Analog Command

The motor speed command is controlled by the analog voltage deviation between V\_REF and VGND. Use parameter P1-40 to adjust the speed-control slope and its range.

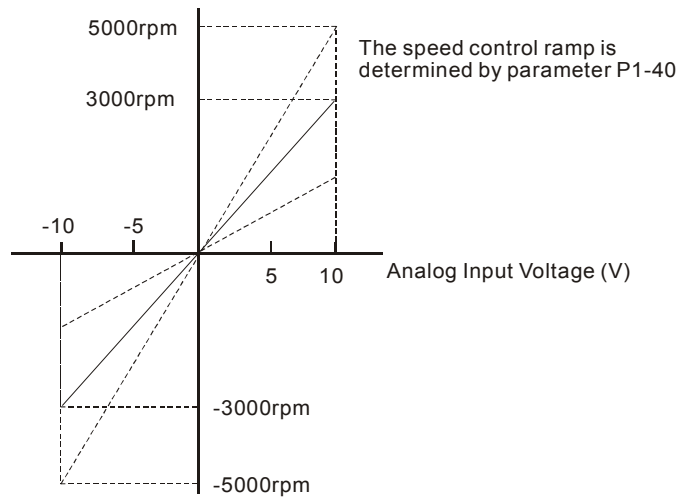

Related parameters:

<b>P1-40 ▲</b>	<b>VCM</b>	<b>Maximum Speed of Analog Speed Command</b>	<b>Address: 0150H 0151H</b>
Operational Interface :		Panel / Software	Communication
Default :		Same as the rated speed of each model	
Control Mode :		S / T	
Unit :		r/min	
Range :		0 ~ 5000	
Data Size :		16-bit	
Format :		Decimal	

Settings : Maximum Speed of Analog Speed Command:  
 In speed mode, the analog speed command inputs the swing speed setting of the max. voltage (10V).  
 For example, if the setting is 3000, when the external voltage input is 10V, it means the speed control command is 3000r/min. If the external voltage input is 5V, then the speed control command is 1500r/min.  

$$\text{Speed control command} = \text{input voltage value} \times \text{setting value} / 10$$
 In position or torque (force) mode, analog speed limit inputs the swing speed limit setting of the max. voltage (10V).  

$$\text{Speed limit command} = \text{input voltage value} \times \text{setting value} / 10$$

### 6.3.5 Timing Diagram in Speed Mode

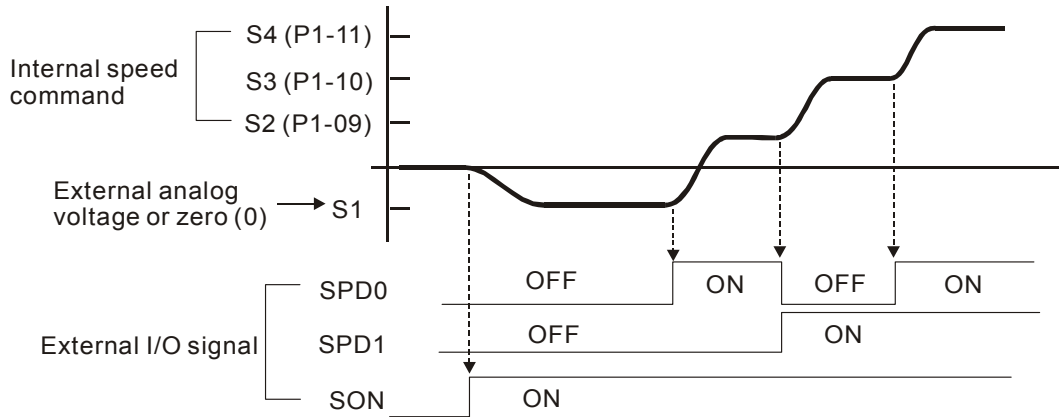

- NOTE**
- 1) OFF means the contact point is open while ON means the contact point is close.
  - 2) When it is in Sz mode, the speed command  $S1 = 0$ ; When it is in S mode, the speed command S1 is the external analog voltage input.
  - 3) When the servo drive is On, please select the command according to SPD0~SPD1 status.

### 6.3.6 Gain Adjustment of Speed Loop

Here introduces the function of speed control unit. The following shows its structure.

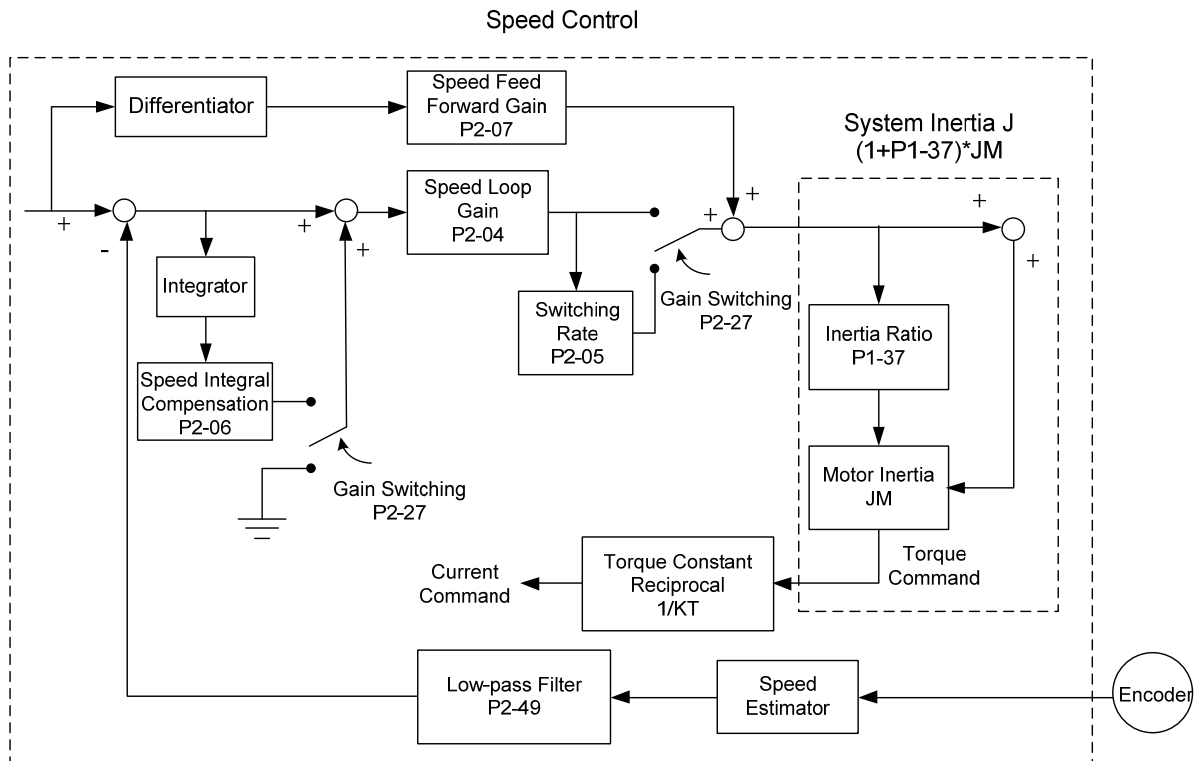

Many kinds of gain in speed control unit are adjustable. Two ways, manual and auto, are provided for selection.

Manual: All parameters are set by users and the auto or auxiliary function will be disabled in this mode.

Auto: General load inertia estimation is provided. It adjusts the parameter automatically. Its framework is divided into PI auto gain adjustment and PDFF auto gain adjustment.

Parameter P2-32 can be used to adjust the gain.

P2-32 ▲	AUT2	Tuning Mode Selection	Address: 0240H 0241H
Operational Interface :	Panel / Software	Communication	Related Section: 5.6 and 6.3.6
Default :	0		
Control Mode :	ALL		
Unit :	-		
Range :	0 ~ 0x2		
Data Size :	16-bit		
Format :	Hexadecimal		
Settings :	0: Manual Mode 1: Auto Mode (continuous adjustment) 2: Semi-auto Mode (non- continuous adjustment)		
	Relevant description of manual mode setting: When P2-32 is set to 0, parameters related to gain control, such as P2-00, P2-02, P2-04, P2-06, P2-07, P2-25 and P2-26, all can be set by the user. When switching mode from auto or semi-auto to manual, parameters about gain will be updated automatically.		
	Relevant description of auto mode setting: Continue to estimate the system inertia, save the inertia ratio to P1-37 every 30 minutes automatically and refer to the stiffness and bandwidth setting of P2-31.		
	<ol style="list-style-type: none"> <li>1. Set the system to manual mode 0 from auto 1 or semi-auto 2, the system will save the estimated inertia value to P1-37 automatically and set the corresponding parameters.</li> <li>2. Set the system to auto mode 1 or semi-auto mode 2 from manual mode 0, please set P1-37 to the appropriate value.</li> <li>3. Set the system to manual mode 0 from auto mode 1, P2-00, P2-04, P2-06, P2-25, P2-26 and P2-49 will be modified to the corresponding parameters of auto mode.</li> <li>4. Set the system to manual mode 0 from semi-auto mode 2, P2-00, P2-04, P2-06, P2-25, P2-26 and P2-49 will be modified to the corresponding parameters of semi-auto mode.</li> </ol>		
	Relevant description of semi-auto mode setting:		

Relevant description of semi-auto mode setting:

1. When the system inertia is stable, the value of P2-33 will be 1 and the system stops estimating. The inertia value will be saved to P1-37 automatically. When switching mode to semi-auto mode (from manual or auto mode), the system starts to estimate again.
2. When the system inertia is over the range, the value of P2-33 will be 0 and the system starts to estimate and adjust again.

## Manual Mode

When P2-32 is set to 0, users can define Speed Loop Gain (P2-04), Speed Integral Compensation (P2-06) and Speed Feed Forward Gain (P2-07). Influence of each parameter is as the followings.

Proportional gain: To increase proportional gain can enhance the response frequency of speed loop.

Integral gain: To increase the integral gain could increase the low-frequency stiffness of speed loop, reduce the steady-state error and sacrifice the phase margin. The over high integral gain will cause the instability of the system.

Feed forward gain: Diminish the deviation of phase delay.

Relevant parameters:

P2-04	KVP	Speed Loop Gain	Address: 0208H 0209H
	Operational Interface :	Panel / Software	Communication
	Default :	500	
	Control Mode :	ALL	
	Unit :	rad/s	
	Range :	0 ~ 8191	
	Data Size :	16-bit	
	Format :	Decimal	
	Settings :	Increase the value of speed loop gain can enhance the speed response. However, if the value is set too big, it would easily cause resonance and noise.	
			Related Section: 6.3.6

P2-06	KVI	Speed Integral Compensation	Address: 020CH 020DH
	Operational Interface :	Panel / Software	Communication
	Default :	100	
			Related Section: 6.3.6

Control Mode :	ALL
Unit :	rad/s
Range :	0 ~ 1023
Data Size :	16-bit
Format :	Decimal

Settings : Increasing the value of speed integral compensation can enhance speed response and diminish the deviation of speed control. However, if the value is set too big, it would easily cause resonance and noise.

<b>P2-07</b>	<b>KVF</b>	<b>Speed Feed Forward Gain</b>	<b>Address: 020EH 020FH</b>
--------------	------------	--------------------------------	---------------------------------

Operational Interface :	Panel / Software	Communication	Related Section: 6.3.6
Default :	0		
Control Mode :	ALL		
Unit :	%		
Range :	0 ~ 100		
Data Size :	16-bit		
Format :	Decimal		

Settings : When the speed control command runs smoothly, increasing the gain value can reduce the speed command error. If the command does not run smoothly, decreasing the gain value can reduce the mechanical vibration during operation.

Theoretically, stepping response can be used to explain proportional gain (KVP), integral gain (KVI) and feed forward gain (KVF). Here, the frequency domain and time domain are used to illustrate the basic principle.

**Frequency Domain**

STEP 1: Set the value of KVI=0, the value of KVF=0 and adjust the value of KVP.

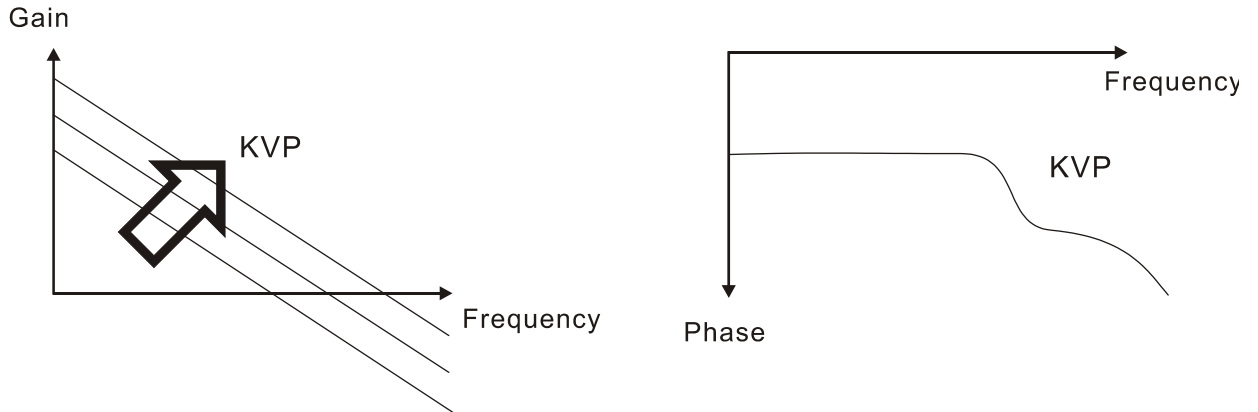

STEP 2 : Fix the value of KVP and adjust the value of KVI.

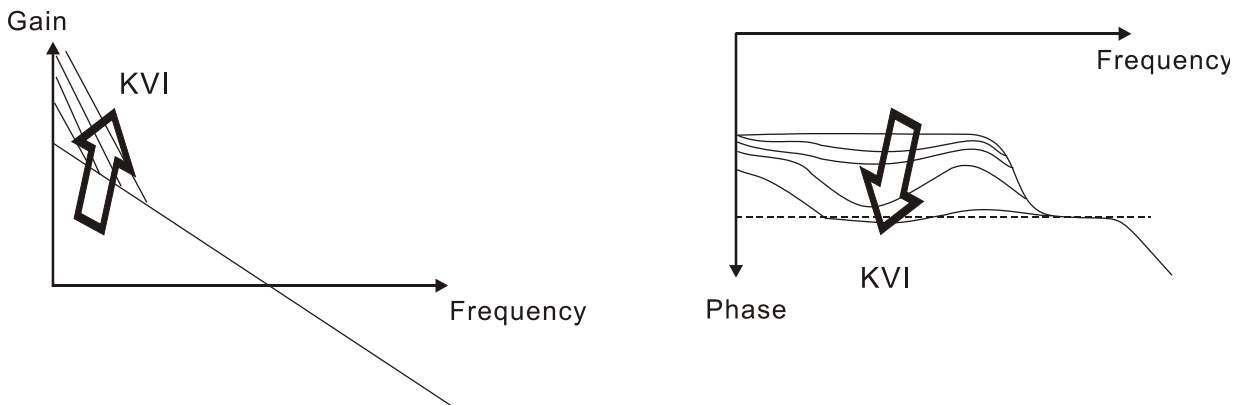

STEP 3 : Select the value of KVI, if the value of phase margin is too small, re-adjust the value of KVP again to obtain the value, 45deg of phase margin.

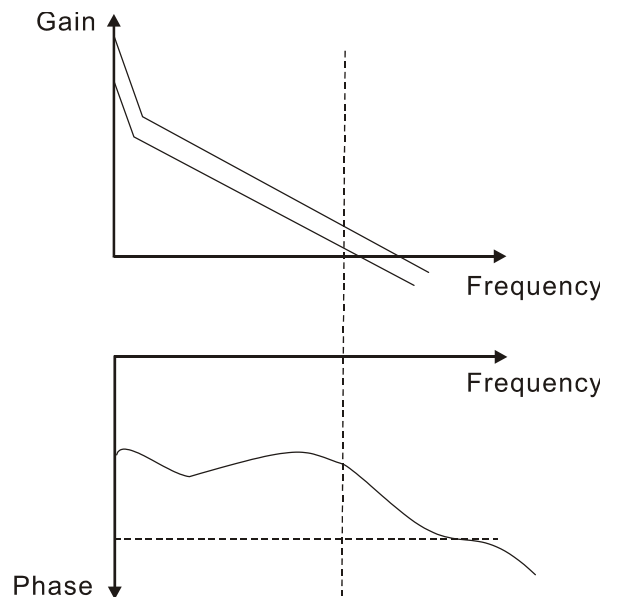

**Time Domain**

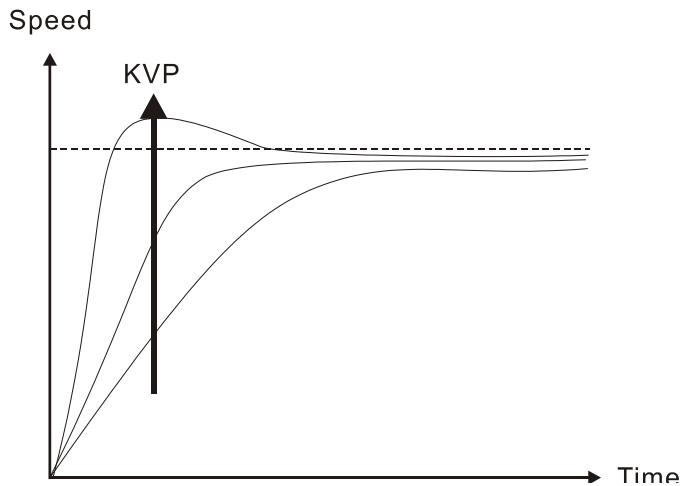

The bigger KVP value cause higher bandwidth and shorten the rising time. However, if the value is set too big, the phase margin will be too small.

To steady-state error, the result is not as good as KVI. But it helps to reduce the dynamic following error.

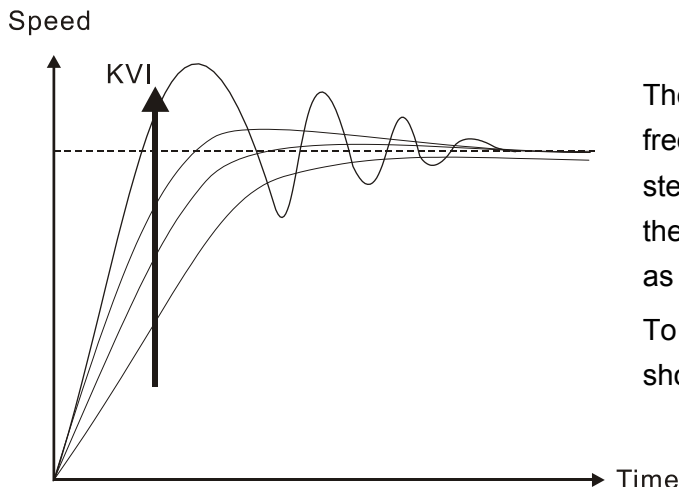

The bigger KVI value cause greater low-frequency gain and shorten the time the steady-state error returns to zero. However, the phase margin will dramatically decrease as well.

To steady-state error, it is very helpful but shows no benefit to dynamic following error.

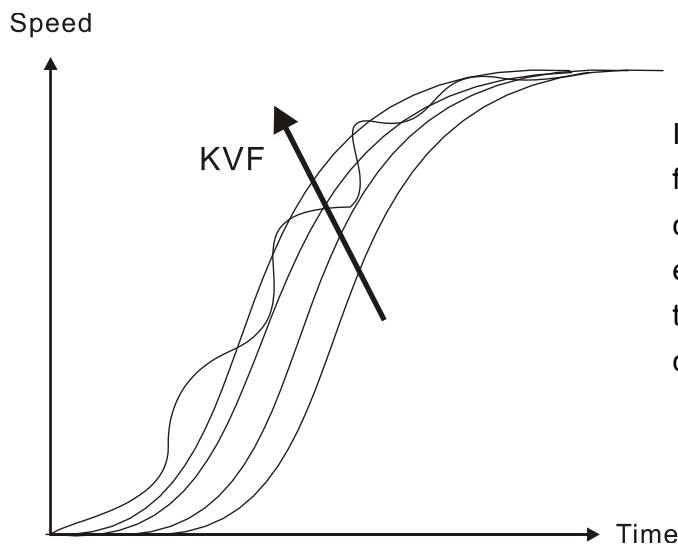

If the KVF value closes to 1, the feed forward compensation will be more complete and the dynamic following error will become smaller. However, if the KVF value is set too big, it would cause vibration.

Generally, instrument is needed when applying frequency domain for measurement. Users are required to adopt the measurement techniques; while time domain only needs a scope and goes with the analog input / output terminal provided by the servo drive. Thus, time domain is frequently

used to adjust PI controller. The abilities of PI controller to deal with the resistance of torque load and the following command are the same.

That is to say, the following command and resistance of torque load have the same performance in frequency domain and time domain. Users can reduce the bandwidth by setting the low-pass filter in command end.

### Auto Mode

Auto mode adopts adaptive principle. The servo drive automatically adjusts the parameters according to the external load. Since the adaptive principle takes longer time, it will be unsuitable if the load changes too fast. It would be better to wait until the load inertia is steady or changes slowly. Depending on the speed of signal input, the adaptive time will be different from one another.

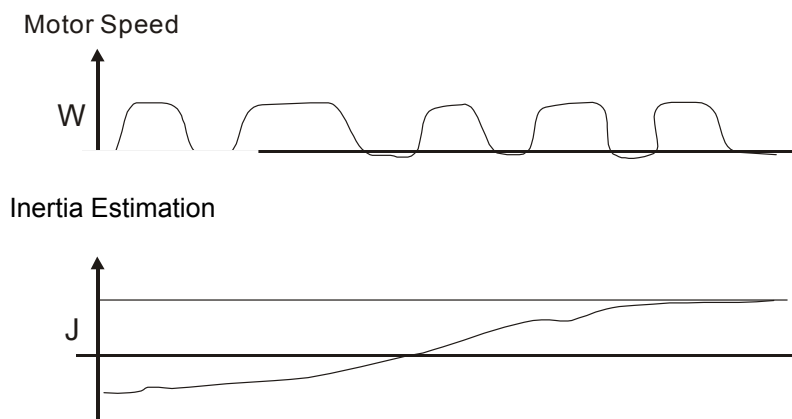



### 6.3.7 Resonance Suppression

When resonance occurs, it is probably because the stiffness of the control system is too strong or the response is too fast. Eliminating these two factors might improve the situation. In addition, low-pass filter (parameter P2-25) and notch filter (parameter P2-23 and P2-24) are provided to suppress the resonance if not changing the control parameters.

Related parameters:

P2-23	NCF1	Resonance Suppression (Notch filter) (1)	Address: 022EH 022FH
	Operational Interface :	Panel / Software      Communication	Related Section: 6.3.7
	Default :	1000	
	Control Mode :	ALL	
	Unit :	Hz	
	Range :	50 ~ 1000	
	Data Size :	16-bit	
	Format :	Decimal	
	Settings :	The first setting value of resonance frequency. If P2-24 is set to 0, this function is disabled. P2-43 and P2-44 are the second Notch filter.	

P2-24	DPH1	Resonance Suppression (Notch filter) Attenuation Rate (1)	Address: 0230H 0231H
	Operational Interface :	Panel / Software      Communication	Related Section: 6.3.7
	Default :	0	
	Control Mode :	ALL	
	Unit :	dB	
	Range :	0 ~ 32 (0: disable the function of Notch filter)	
	Data Size :	16-bit	
	Format :	Decimal	
	Settings :	The first resonance suppression (notch filter) attenuation rate. When this parameter is set to 0, the function of Notch filter is disabled.	



#### NOTE

If the value of attenuation rate is set to 5, then, it would be -5dB.

P2-43	NCF2	Resonance Suppression (Notch filter) (2)	Address: 0256H 0257H
Operational Interface :		Panel / Software	Communication
Default :		1000	
Control Mode :		ALL	
Unit :		Hz	
Range :		50 ~ 2000	
Data Size :		16-bit	
Format :		Decimal	
Settings : The second setting value of resonance frequency. If P2-44 is set to 0, this function is disabled. P2-23 and P2-24 are the first Notch filter.			

P2-44	DPH2	Resonance Suppression (Notch filter) Attenuation Rate (2)	Address: 0258H 0259H
Operational Interface :		Panel / Software	Communication
Default :		0	
Control Mode :		ALL	
Unit :		dB	
Range :		0 ~ 32 (0: disable Notch filter)	
Data Size :		16-bit	
Format :		Decimal	
Settings : The second resonance suppression (notch filter) attenuation rate. When this parameter is set to 0, the function of Notch filter is disabled.			

**NOTE**

If the value of attenuation rate is set to 5, then it would be -5dB.

P2-46	DPH3	Resonance Suppression (Notch filter) Attenuation Rate (3)	Address: 025CH 025DH
Operational Interface :		Panel / Software	Communication
Default :		0	
Control Mode :		ALL	

Unit :	dB
Range :	0 ~ 32
Data Size :	16-bit
Format :	Decimal

Settings : The third group of resonance suppression (Notch filter) attenuation rate. Set the value to 0 to disable the function of Notch filter.

<b>P2-25</b>	<b>NLP</b>	<b>Low-pass Filter of Resonance Suppression</b>	<b>Address: 0232H 0233H</b>
	Operational Interface :	Panel / Software	Communication
	Default :	0.2 (under 1kW) or 0.5 (other model)	2 (under 1kW) or 0.5 (other model)
	Control Mode :	ALL	
	Unit :	1 ms	0.1 ms
	Range :	0.0 ~ 100.0	0 ~ 1000
	Data Size :	16-bit	
	Format :	One decimal	Decimal
	Example :	1.5 = 1.5 ms	15 = 1.5 ms
	Related Section:	6.3.7	

Settings : Set the low-pass filter of resonance suppression. When the value is set to 0, the function of low-pass filter is disabled.

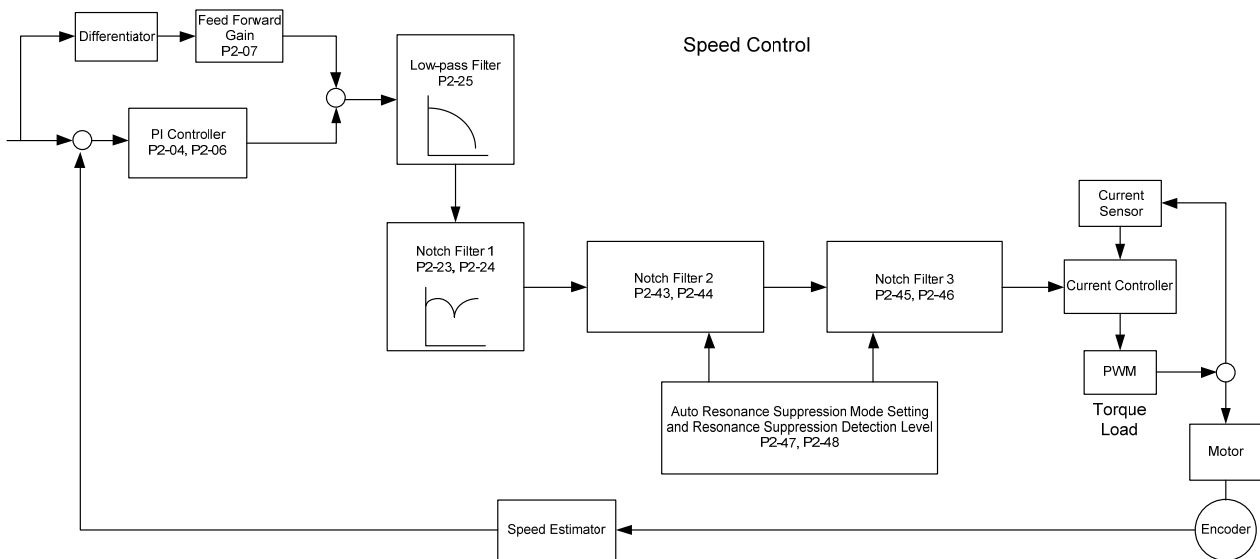

There are two sets of auto resonance suppression, one is P2-43 and P2-44 and another one is P2-45 and P2-46. When the resonance occurs, set P2-47 to 1 or 2 (enable the function of resonance suppression), the servo drive searches the point of resonance frequency and suppresses the resonance automatically. Write the point of frequency into P2-43 and P2-45 and write the attenuation rate into P2-44 and P2-46. When P2-47 is set to 1, the system will set P2-47 to 0 (disable the function of auto suppression) automatically after completing resonance suppression and the system is stable for 20 minutes. When P2-47 is set to 2, the system will keep searching the point of resonance.

When P2-47 is set to 1 or 2, but resonance still exists, please confirm the value of parameter P2-44 and P2-46. If one of them is 32, it is suggested to reduce the speed bandwidth first and then start to estimate again. If the value of both is smaller than 32 and resonance still exists, please set P2-47 to 0 first and then manually increase the value of P2-44 and P2-46. It is suggested to reduce the bandwidth if the resonance has not been improved. Then use the function of auto resonance suppression.

When manually increase the value of P2-44 and P2-46, please check if the value of both is bigger than 0. If yes, it means the frequency point of P2-43 and P2-45 is the one searched by auto resonance suppression. If the value of both is 0, it means the default, 1000 of P2-43 and P2-45 is not the one searched by auto resonance suppression. Deepen the resonance suppression attenuation rate might worsen the situation.

Settings of P2-47		
Current Value	Desired Value	Function
0	1	Clear the setting value of P2-43 ~ P2-46 and enable auto resonance suppression function.
0	2	Clear the setting value of P2-43 ~ P2-46 and enable auto resonance suppression function.
1	0	Save the setting value of P2-43 ~ P2-46 and disable auto resonance suppression function.
1	1	Clear the setting value of P2-43 ~ P2-46 and enable auto resonance suppression function.
1	2	Do not clear the setting value of P2-43 ~ P2-46 and enable auto resonance suppression function continuously.
2	0	Save the setting value of P2-43 ~ P2-46 and disable auto resonance suppression function.
2	1	Clear the setting value of P2-43 ~ P2-46 and enable auto resonance suppression function.
2	2	Do not clear the setting value of P2-43 ~ P2-46 and enable auto resonance suppression function continuously.

Flowchart of Auto Resonance Suppression:

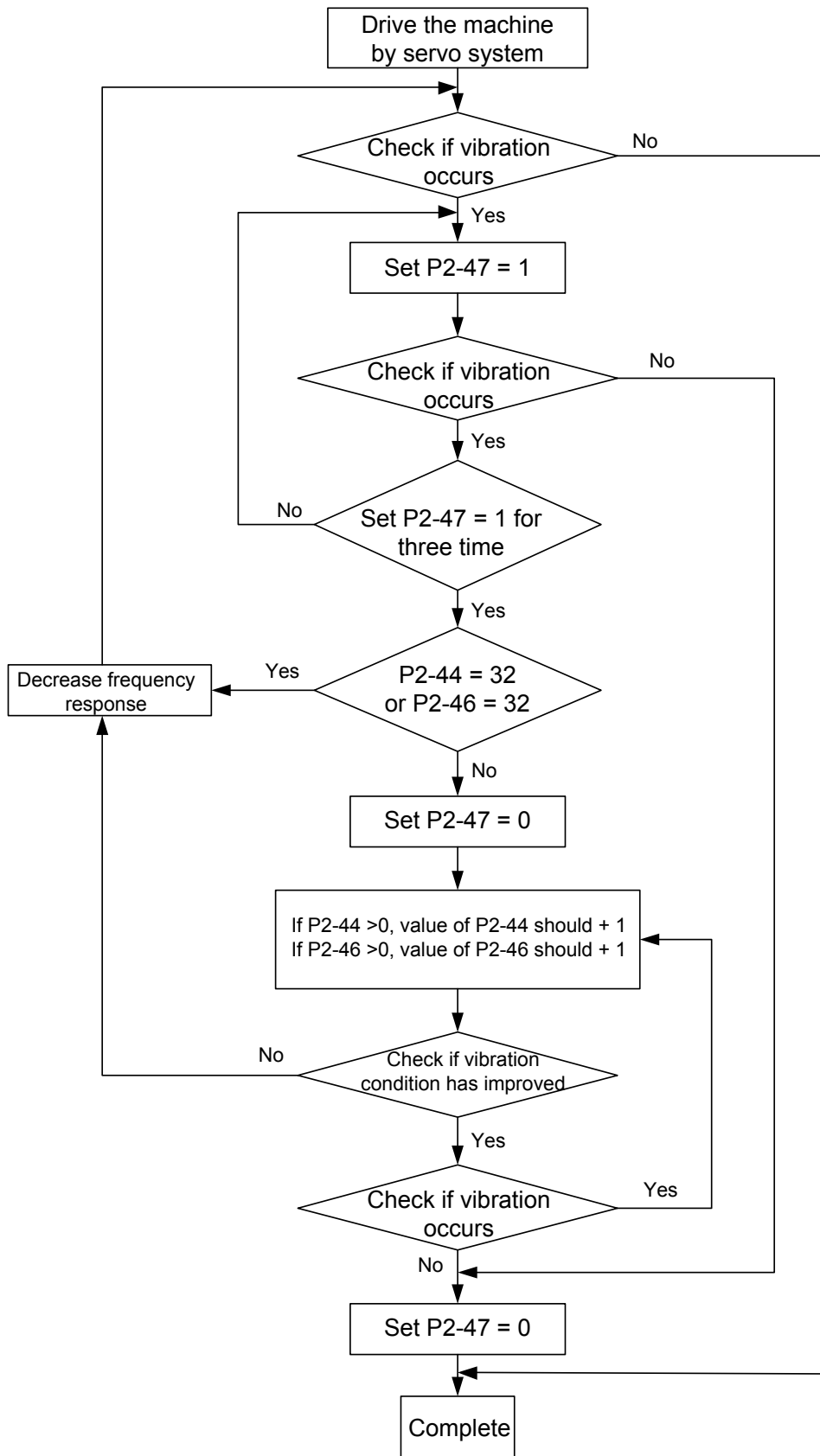

Here illustrates the effect via low-pass filter (parameter P2-25). The following diagram is the system open-loop gain with resonance.

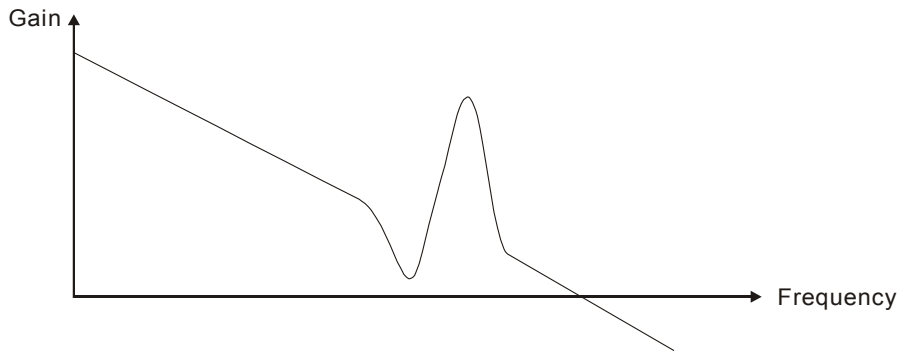

When the value of P2-25 is increased from 0, BW becomes smaller (See as the following diagram). Although it solves the problem of resonance frequency, the response bandwidth and phase margin is reduced.

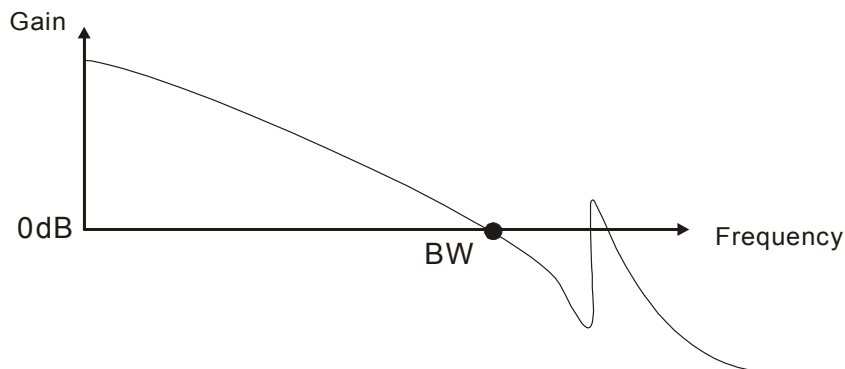

If users know the resonance frequency, notch filter (parameter P2-23 and P2-24) can directly eliminate the resonance. The frequency setting range of notch filter is merely from 50 to 1000Hz. The suppression strength is from 0 to 32dB. If the resonance frequency is not within the range, it is suggested to use low-pass filter (parameter P2-25).

Here firstly illustrates the influence brought by notch filter (P2-23 and P2-24) and low-pass filter (P2-25). The following diagrams are the system of open-loop gain with resonance.

Resonance suppression with notch filter

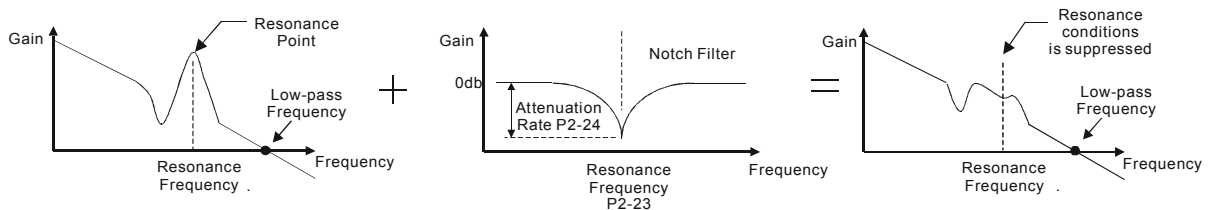

## Resonance suppression with low-pass filter

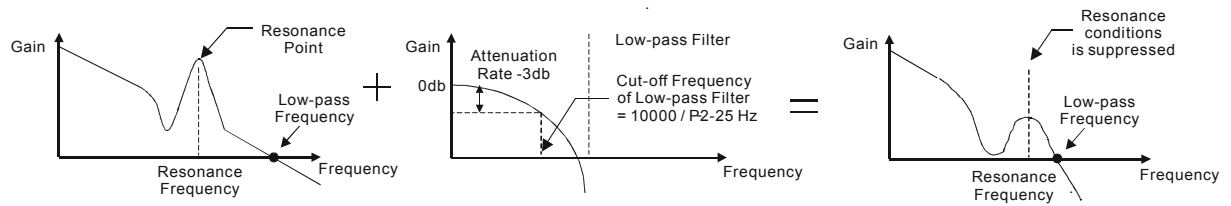

When the value of P2-25 is increased from 0, BW becomes smaller. Although it solves the problem of resonance frequency, the response bandwidth and phase margin is reduced. Also, the system becomes unstable.

If users know the resonance frequency, notch filter (parameter P2-23 and P2-24) can directly eliminate the resonance. In this case, notch filter will be more helpful than low-pass filter. However, if the resonance frequency drifts because of time or other factors, notch filter will not do.

## 6.4 Torque Mode

Torque control mode (T or Tz) is appropriate in torque control application, such as printing machine, winding machine, etc. There are two kinds of command source, analog input and register. Analog command input uses external voltage to control the torque of the motor while register uses the internal parameters (P1-12~P1-14) as the torque command.

### 6.4.1 Selection of Torque Command

Torque command source are external analog voltage and parameters. It uses CN1 DI signal for selection. See as below.

Torque Command	DI signal of CN1		Command Source		Content	Range	
	TCM1	TCM0					
T1	0	0	Mode	T	External analog command	Voltage between T-REF-GND	-10V ~ +10V
				Tz	None	Torque command is 0	0
T2	0	1	Parameters		P1-12	-300% ~ 300%	
T3	1	0			P1-13		
T4	1	1			P1-14		

- The status of TCM0 ~ TCM1: 0 means DI OFF and 1 means DI ON.
- When TCM0 = TCM1 = 0, if it is in Tz mode, then the command is 0. Thus, if there is no need to use analog voltage as torque command, Tz mode is applicable and can avoid the problem of zero drift. If it is in T mode, the command will be the voltage deviation between T-REF and GND. Its input voltage range is -10V ~ +10V, which mean the corresponding torque is adjustable (P1-41).
- When neither TCM0 nor TCM1 is 0, parameters become the source of torque command. The command will be executed after TCM0 ~ TCM1 are changed. There is no need to use CTRG for triggering.

The torque command can be used in torque mode (T or Tz) and speed mode (S or Sz). When it is in speed mode, it can be regarded as the command input of torque limit.



## 6.4.2 Control Structure of Torque Mode

The basic control structure is as the following diagram:

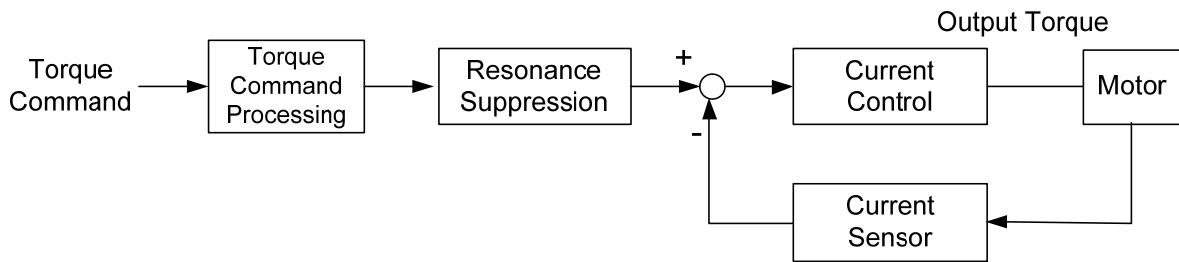

The torque command unit is to select torque command source according to Section 6.4.1, including the scaling (P1-41) setting and S-curve setting. The current control unit manages the gain parameters of the servo drive and calculates the current for servo motor in time. Since the current control unit is very complicated, and is not relevant to the application. There is no need to adjust parameters. Only command end setting is provided.

The structure of torque command unit is as the following diagram.

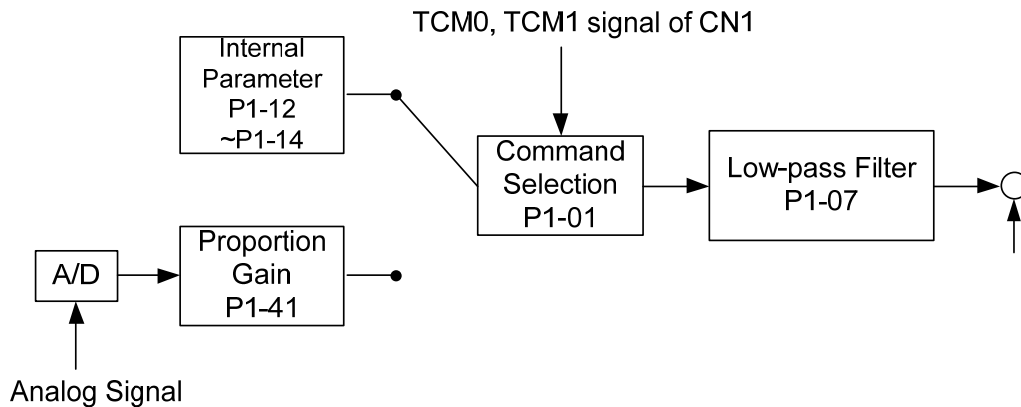

The upper path is the command from register while the lower one is external analog command. The command is selected according to the status of TCM0, TCM1 and P1-01 (T or Tz). The torque represented by analog voltage command can be adjusted via the scaling and can obtain a smoother response via low-pass filter.

### 6.4.3 Smooth Torque Command

Related parameters:

<b>P1-07</b>	<b>TFLT</b>	<b>Analog Torque Command (Low-pass Filter)</b>	<b>Address: 010EH 010FH</b>
	Operational Interface :	Panel / Software      Communication	Related Section: 6.4.3
	Default :	0	
	Control Mode :	T	
	Unit :	ms	
	Range :	0 ~ 1000 (0: disable this function)	
	Data Size :	16-bit	
	Format :	Decimal	
Settings :	0: Disabled		

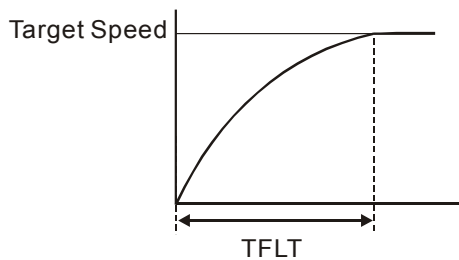

### 6.4.4 The Scaling of Analog Command

The motor torque command is controlled by the analog voltage deviation between T\_REF and GND and goes with parameter P1-41 to adjust the torque slope and its range.

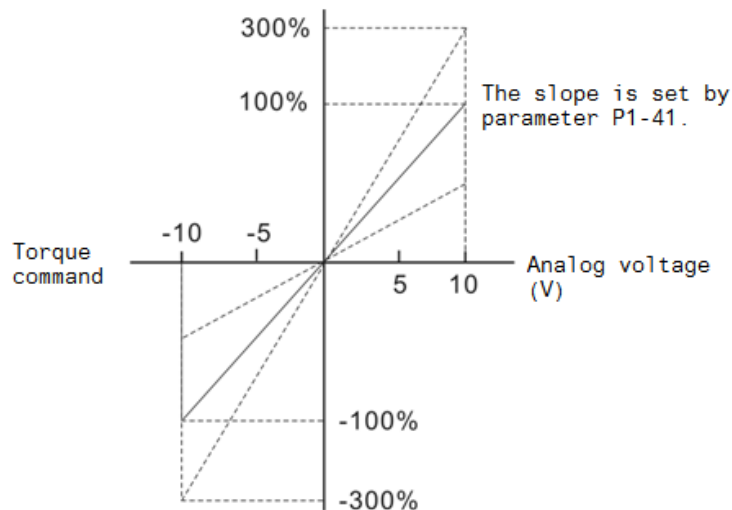

Related parameters:

<b>P1-41▲</b>	<b>TCM</b>	<b>Maximum Output of Analog Torque Command</b>	<b>Address: 0152H 0153H</b>
	Operational Interface :	Panel / Software      Communication	Related Section: 6.4.4
	Default :	100	
	Control Mode :	ALL	
	Unit :	%	
	Range :	0 ~ 1000	
	Data Size :	16-bit	
	Format :	Decimal	

Settings : Maximum Output of Analog Torque Command:

In torque mode, the analog torque command inputs the torque setting of the max. voltage (10V). When the default setting is 100, if the external voltage inputs 10V, it means the torque control command is 100% rated torque. If the external voltage inputs 5V, then the torque control command is 50% rated torque.

$$\text{Torque control command} = \text{input voltage value} \times \text{setting value} / 10 (\%)$$

In speed, PT and PR mode, the analog torque limit inputs the torque limit setting of the max. voltage (10V).

$$\text{Torque limit command} = \text{input voltage value} \times \text{setting value} / 10 (\%)$$

### 6.4.5 Timing Diagram in Torque Mode

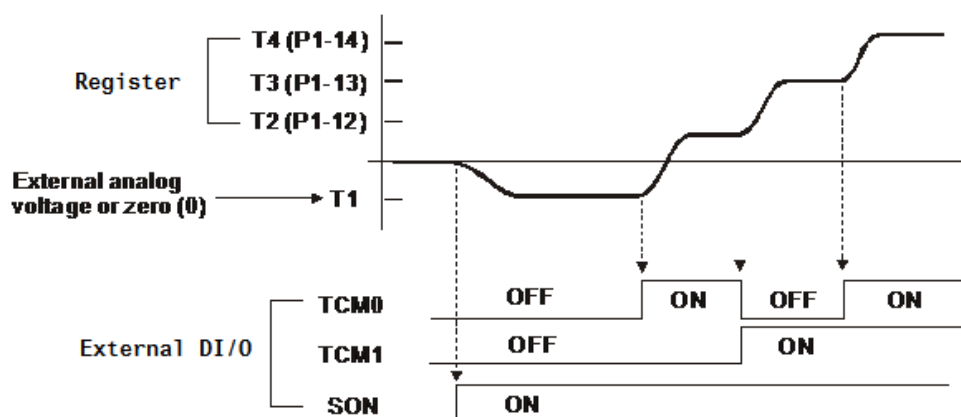

- NOTE**
1. OFF means the contact point is open while ON means the contact point is close.
  2. When it is in Tz mode, the torque command T1 = 0; When it is in T mode, the torque command T1 is the external analog voltage input.
  3. When it is Servo On, please select the command according to TCM0~TCM1 status.

## 6.5 Dual Mode

Apart from single mode, dual mode is also provided for operation. According to Section 6.1, dual modes are as followings:

1. Speed/position dual mode (PT-S, PR-S, PT-PR)
2. Speed/torque dual mode (S-T)
3. Torque/position dual mode (PT-T, PR-T)
4. Position speed multi mode (PT-PR-S)
5. Position torque multi mode (PT-PR-T)

Mode Name	Short Name	Setting Code	Description
Dual Mode	PT-S	06	<b>PT</b> and <b>S</b> can be switched via <b>DI</b> signal, <b>S_P</b> .
	PT-T	07	<b>PT</b> and <b>T</b> can be switched via <b>DI</b> signal, <b>T_P</b> .
	PR-S	08	<b>PR</b> and <b>S</b> can be switched via <b>DI</b> signal, <b>S_P</b> .
	PR-T	09	<b>PR</b> and <b>T</b> can be switched via <b>DI</b> signal, <b>T_P</b> .
	S-T	0A	<b>S</b> and <b>T</b> can be switched via <b>DI</b> signal, <b>S_T</b> .
	PT-PR	0D	<b>PT</b> and <b>PR</b> can be switched via <b>DI</b> signal, <b>PT_PR</b> .
Multiple Mode	PT-PR-S	0E	<b>PT</b> , <b>PR</b> and <b>S</b> can be switched via <b>DI</b> signal, <b>S_P</b> and <b>PT_PR</b> .
	PT-PR-T	0F	<b>PT</b> , <b>PR</b> and <b>T</b> can be switched via <b>DI</b> signal, <b>T_P</b> and <b>PT_PR</b> .

Sz and Tz dual mode is not provided here. For avoiding occupying too many digital inputs in dual mode, speed and torque mode can use external analog voltage as the command source so as to reduce digital input (SPD0, SPD1 or TCM0, TCM1). Please refer to Chapter 3.3.2, table 3.1, Default Value of DI Input Function and table 3.2, Default Value of DO Output Function for the default DI/DO of each mode.

The relationship between DI/DO signals and PIN define are set after the mode is selected. If users desire to change the setting, please refer to Chapter 3.3.4.

### 6.5.1 Speed / Position Dual Mode

There are PT-S and PR-S in speed/position dual mode. The command source of the former one comes from external pulse while the latter one comes from internal parameters (P6-00~P7-27). Speed command could be issued by external analog voltage or internal parameters (P1-09~P1-11). The switch of speed/position mode is controlled by S-P signal and the switch of PR-S mode is controlled by DI signal, which is more complicated. The timing diagram is shown as below.

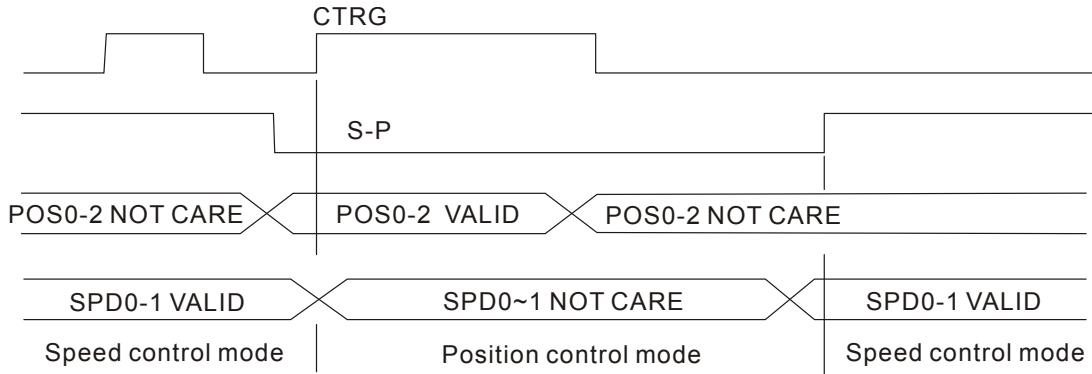

Figure 1. : Speed / Position Control Mode Selection

In speed mode (S-P is ON), the speed command is selected via SPD0 and SPD1. CTRG is not working at the moment. When switching to position mode (S-P is OFF), since position command has not been issued (needs to wait the rising edge of CTRG), the motor stops. The position command is determined by POS0~POS5 and triggered by rising edge of CTRG. When S-P is ON, it goes back to speed mode again. Please refer to the introduction of single mode for DI signal and the selected command of each mode.

### 6.5.2 Speed / Torque Dual Mode

S-T is the only mode. The speed command comes from the external analog voltage and internal parameters (P1-09 ~P1-11), which is selected via SPD0~SPD1. Similarly, the source of torque command could be external analog voltage and internal parameters (P1-12 ~ P1-14) and is selected via TCM0~TCM1. The switch of speed/torque mode is controlled by S-T signal. The timing diagram is shown as below.

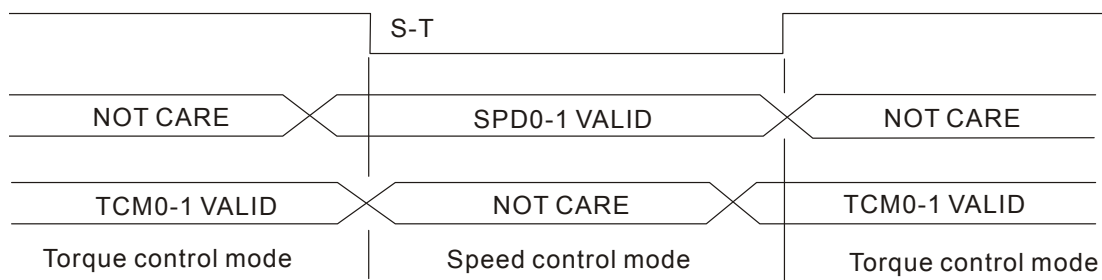

Figure 2. : Speed / Torque Control Mode Selection

In torque mode (S-T is ON), the torque command is selected via TCM0 and TCM1. When switching to speed mode (S-T is OFF), the torque command is selected via SPD0 and SPD 1. The

motor operates according to the speed command. When S-T is ON, it goes back to the torque mode again. Please refer to the introduction of single mode for DI signal and the selected command of each mode.

### 6.5.3 Torque / Position Dual Mode

There are PT-T and PR-T in speed/position dual mode. The command source of the former one comes from external pulse while the latter one comes from internal parameters (P6-00~P7-27). Torque command could be issued by external analog voltage or internal parameters (P1-12~P1-14). The switch of torque/position mode is controlled by T-P signal and the switch of PR-T mode is controlled by DI signal, which is more complicated. The timing diagram is shown as below.

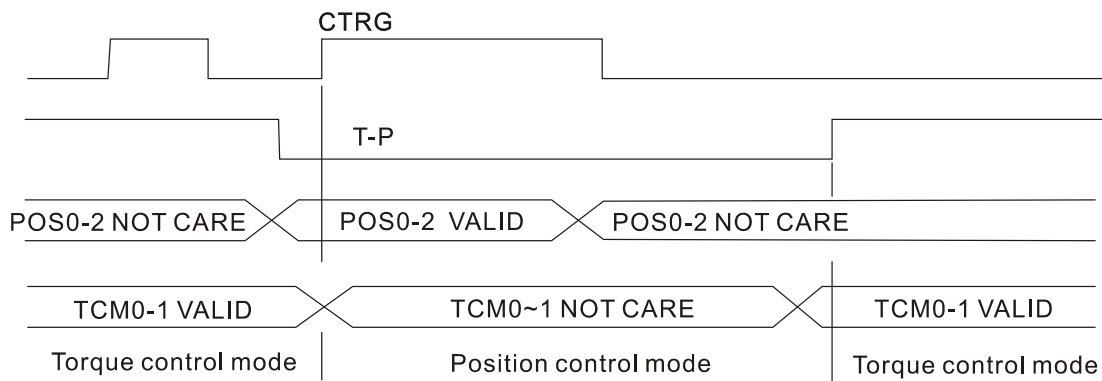

Figure 3. : Torque / Position Control Mode Selection

In torque mode (T-P is ON), the torque command is selected via TCM0 and TCM1. CTRG is not working at the moment. When switching to position mode (T-P is OFF), since position command has not been issued (needs to wait the rising edge of CTRG), the motor stops. The position command is determined by POS0~POS5 and triggered by rising edge of CTRG. When T-P is ON, it goes back to torque mode again. Please refer to the introduction of single mode for DI signal and the selected command of each mode.

## 6.6 Others

### 6.6.1 The Use of Speed Limit

The maximum speed in each mode is limited by internal parameters (P1-55), not matter it is in position, speed or torque mode.

The issuing method of speed limit command and speed command is the same. The command source could be external analog voltage or internal parameter (P1-09 ~ P1-11). Please refer to Section 6.3.1 for descriptions.

Speed limit can be used in torque mode (T) only. It is used for limiting the motor speed. When the command in torque mode is issued by external analog voltage, DI signal is enough and can be regarded as SPD0~SPD1 which is used to determine the speed limit command (internal parameters). If the DI signal is not enough, speed limit command can be issued by analog voltage. When the function of disable/enable limit function in P1-02 is set to 1, the speed limit function is enabled. See the timing diagram as below.

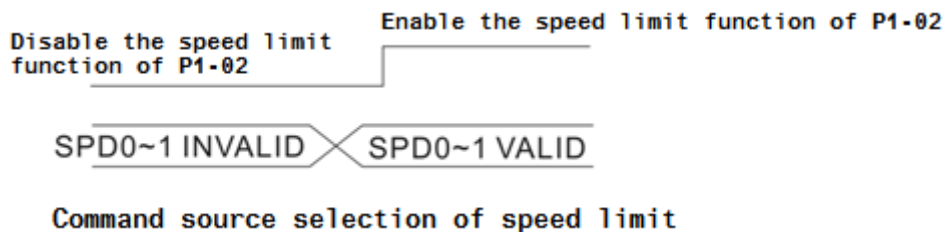

### 6.6.2 The Use of Torque Limit

The issuing method of torque limit command and torque command is the same. The command source could be external analog voltage or internal parameter (P1-12 ~ P1-14). Please refer to Chapter 6.4.1 for descriptions.

Torque limit can be used in position mode (PT, PR) or speed mode (S). It is used for limiting the motor torque output. When the command in position mode is issued by external analog voltage, DI signal is enough and can be regarded as TCM0~TCM1, which is used to determine torque limit command (internal parameters). If the DI signal is not enough, torque limit command can be issued by analog voltage. When the function of disable/enable torque limit function in P1-02 is set to 1, the torque limit function is enabled. See the timing diagram as below.

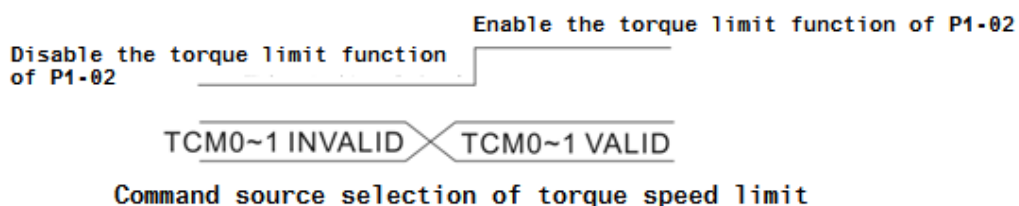

### 6.6.3 Analog Monitor

Users could observe the needed voltage signal via analog monitor. Two analog channels are provided by the servo drive and locate in terminal 15 and 16 of CN1. The related parameter settings are as the followings.

<b>P0-03</b>	<b>MON</b>	<b>Analog Output Monitor</b>	<b>Address: 0006H 0007H</b>
	Operational Interface :	Panel / Software	Communication
	Default :	00	
	Control Mode :	ALL	
	Unit :	-	
	Range :	00 ~ 0x77	
	Data Size :	16-bit	
	Format :	Hecimal	
Settings :			

MON1, MON2 Setting Value	Description
0	Motor speed (+/-8 Volts/Max. speed)
1	Motor torque (force) (+/-8 Volts/Max. torque (force))
2	Pulse command frequency (+8 Volts / 4.5Mpps)
3	Speed command (+/-8 Volts/ Max. speed command)
4	Torque (force) command (+/-8 Volts/Max. torque (force) command)
5	VBUS voltage (+/-8 Volts / 450V)
6	Reserved
7	Reserved



 **NOTE** Please refer to parameter P1-04, P1-05 for proportional setting of analog output voltage.

For example: P0-03 = 01 (MON1 is the analog output of motor speed; MON2 is the analog output of motor torque (force))

$$\text{MON1 output voltage} = 8 \times \frac{\text{Motor speed}}{(\text{Max. speed} \times \frac{P1-04}{100})} \text{ (unit : Volts)}$$

$$\text{MON2 output voltage} = 8 \times \frac{\text{Motor torque}}{(\text{Max. torque (force)} \times \frac{P1-05}{100})}$$

(unit: Volts)

<b>P1-03</b>	<b>AOUT</b>	<b>Polarity Setting of Encoder Pulse Output</b>	<b>Address: 0106H 0107H</b>
	Operational Interface :	Panel / Software	Communication
	Default :	0	
	Control Mode :	ALL	
	Unit :	-	
	Range :	0 ~ 0x13	
	Data Size :	16-bit	
	Format :	Hecimal	

Related Section:  
3.3.3

Settings : 

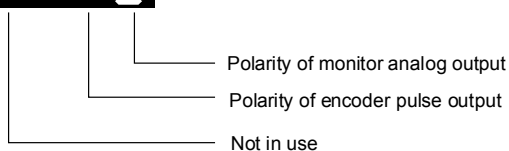

- Polarity of monitor analog output
  - 0: MON1(+), MON2(+)
  - 1: MON1(+), MON2(-)
  - 2: MON1(-), MON2(+)
  - 3: MON1(-), MON2(-)
- Polarity of encoder pulse output
  - 0: Forward output
  - 1: Reverse output

P1-04	MON1	MON1 Analog Monitor Output Proportion	Address: 0108H 0109H
Operational Interface :		Panel / Software	Communication Related Section: 6.4.4
Default :		100	
Control Mode :		ALL	
Unit :		% (full scale)	
Range :		0 ~ 100	
Data Size :		16-bit	
Format :		Decimal	
Settings : Please refer to parameter P0-03 for the setting of analog output selection. For example: P0-03 = 0x00 (MON1 is the speed analog output) When the output voltage value of MON1 is V1: Motor speed = (Max. speed × V1/8) × P1-04/100			

P1-05	MON2	MON2 Analog Monitor Output Proportion	Address: 0108H 0109H
Operational Interface :		Panel / Software	Communication Related Section: 6.4.4
Default :		100	
Control Mode :		ALL	
Unit :		% (full scale)	
Range :		0 ~ 100	
Data Size :		16-bit	
Format :		Decimal	
Settings : Please refer to parameter P0-03 for the setting of analog output selection. For example: P0-03 = 0x00 (MON2 is the speed analog output) When the output voltage value of MON2 is V2: Motor speed = (Max. × V2/8) × P1-05/100			

P4-20	DOF1	Offset Adjustment Value of Analog Monitor Output (Ch1)	Address: 0428H 0429H
	Operational Interface :	Panel / Software      Communication	Related Section: 6.4.4
	Default :	0	
	Control Mode :	ALL	
	Unit :	mV	
	Range :	-800 ~ 800	
	Data Size :	16-bit	
	Format :	Decimal	
	Settings :	Offset adjustment value (cannot reset)	

P4-21	DOF2	Offset Adjustment Value of Analog Monitor Output (Ch2)	Address: 042AH 042BH
	Operational Interface :	Panel / Software      Communication	Related Section: 6.4.4
	Default :	0	
	Control Mode :	ALL	
	Unit :	mV	
	Range :	-800 ~ 800	
	Data Size :	16-bit	
	Format :	Decimal	
	Settings :	Offset adjustment value (cannot reset)	

For example, if users desire to observe the voltage signal in channel 1 and set this channel for observing the pulse command frequency, when the pulse command frequency 2.25M corresponds to 8V output voltage, users need to adjust the monitor output proportion of P1-04 to 50 (= 2.25M/Max. input frequency). Other related settings include P0-03 (X= 3) and P1-03 (The polarity setting range of monitor analog output is between 0 and 3, and it can set positive/negative polarity output). Generally speaking, the output voltage of Ch1 is  $V_1$ ; the pulse command frequency is  $(\text{Max. input frequency} \times V_1/8) \times P1-04/100$ .

Because of the offset value, the zero voltage level of analog monitor output does not match to the zero point of the setting. This can be improved via the setting of offset adjustment value of analog

monitor output, DOF1 (4-20) and DOF2 (P4-21). The voltage level of analog monitor output is  $\pm 8V$ , if the output voltage exceeds the range, it will be limited within  $\pm 8V$ . The provided resolution is about 10bits, which equals to 13mV/LSB.

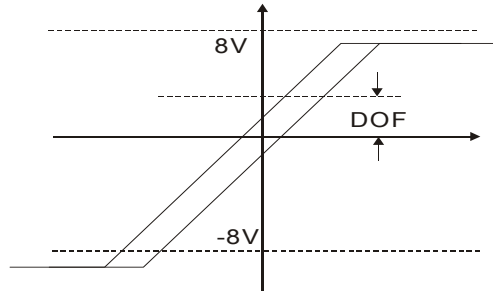

### 6.6.4 The Use of Brake

When operating brake via servo drive, if the DO signal, BRKR is set to OFF, it means the brake is not working and the motor will be locked. If BRKR is set to ON, it means the brake is working and the motor can operate. The operation of brake has two kinds. Users can set the relevant delay via register MBT1 (P1-42) and MBT2 (P1-43). It is usually applied in Z axis in order to reduce the heat generated when servo motor puts up resistance and shorten its lifetime. In order to avoid the error of brake, it must be worked when the servo drive is off. To operate the brake, the brake has to be activated before the motor stops running (Servo OFF). The brake has to be released after Servo ON. Otherwise, it would become the loading of the motor and might damage the brake.

If it works during the process of acceleration or constant speed, the servo drive needs to generate more current to resist the brakeforce of brake and it might cause the alarm of overload warning.

Timing diagram of brake control:

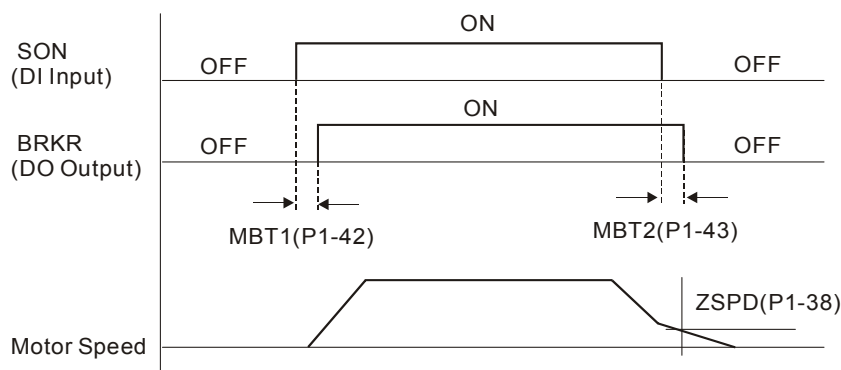

The output timing of BRKR:

1. When Servo OFF, go through the time set by P1-43 and the motor speed is faster than the setting in P1-38, DO.BRKR is OFF (the brake is locked).

- When Servo Off, has not reached the time set by P1-43 but the motor speed is slower than the setting in P1-38, DO.BRKR is OFF (the brake is locked.).

The wiring diagram of using mechanical brake:

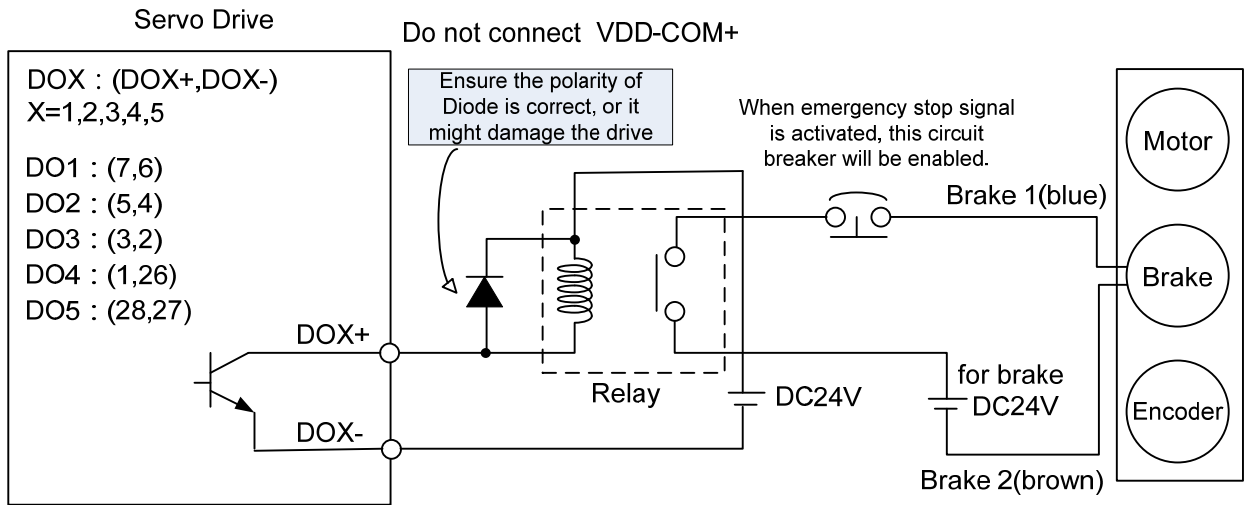

- Please refer to Chapter 3, Wiring.
- The brake signal controls the solenoid valve, provides power to the brake and enables the brake.
- Please note that there is no polarity in coil brake.
- Do not use brake power and control power (VDD) at the same time.

Timing diagram of control power and main power:

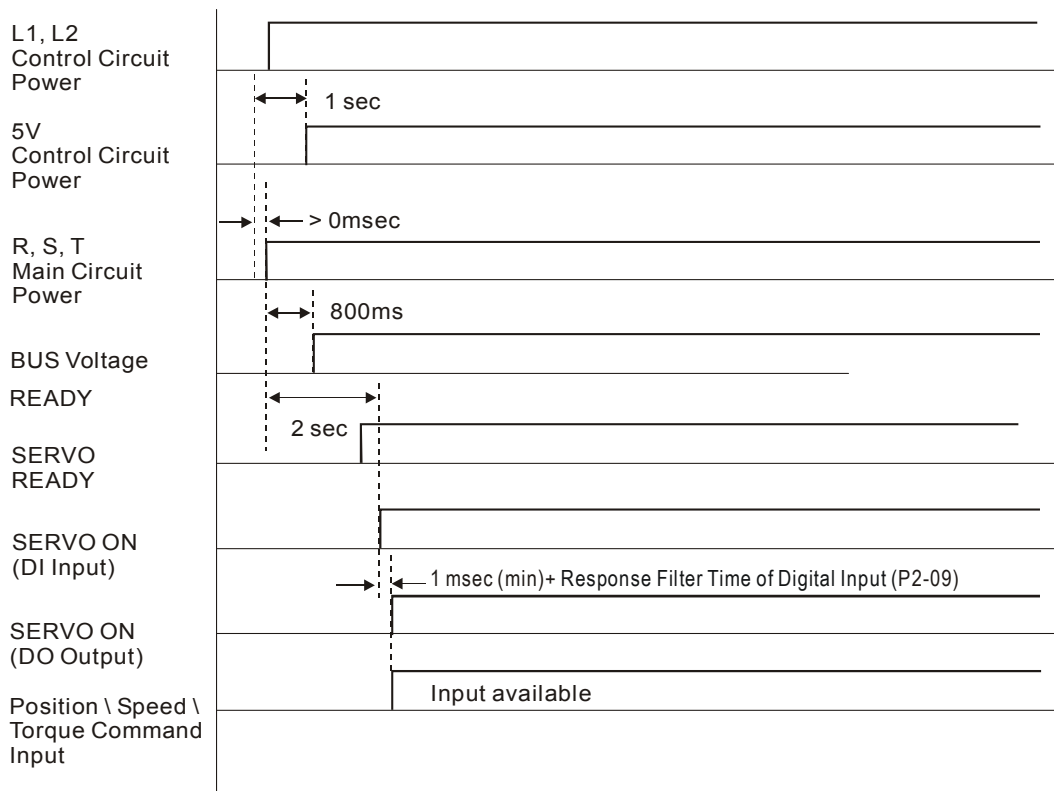

# Chapter 7 Motion Control

## 7.1 Motion Control Functions of ASDA-A2

- 1) Single-axis motion controller of PR (Procedure) control
- 2) Function of Capture (data capture) / Compare (data compare)
- 3) Electronic Cam (E-Cam) function (ASDA-A2 series L type models do not provide this function.)

## 7.2 System Information

The information of the servo drive can be divided into three parts: System parameters, Monitoring variables and Data array.

Descriptions are as follows:

	System Parameters	Monitoring variables
Functional Description	It is used to be the reference mode, important data or operation condition when the servo drive is operating, e.g. Control Mode, Servo Loop Gain, etc.	The status of the servo drive or motor, e.g. motor position, speed, electric current, etc.
Display Format	Panel displays PX-XX. Pressing the <b>SET</b> Key to display parameters and start setting. Please refer to Chapter 4 for Panel Display and Operation.	Set P0-02 to Monitoring variables code and enter into Monitor Mode. The panel will display the value of the variable. Or pressing the <b>MODE</b> Key on the panel to switch to Monitor Mode. Please refer to Chapter 4 for Panel Display and Operation.
Access Method	Readable and writable (depends on parameters)	Read-only
Data Size	16-bit or 32-bit (depends on parameters)	32-bit integers only
Communication	Access via MODBUS / CANopen / USB Each parameter occupies two MODBUS addresses	<ul style="list-style-type: none"> <li>● It only can be monitored via PC software by connecting USB</li> <li>● It does not directly support MODBUS / CANopen access, unless mapping is for corresponding the specified monitoring variables to system parameters.</li> </ul>
Mapping Support	8 groups of parameter, P0-25 ~ P0-32 (set by P0-35 ~ P0-42)	5 groups of parameter, P0-09 ~ P0-13 (set by P0-17 ~ P0-21)
Note		In Monitor Mode, pressing <b>UP/DOWN</b> Key on the panel to switch the commonly used monitoring variables

	(code 0~26); however, it cannot display all (about 150 in total)
--	--

### 7.2.1 Description of Monitoring Variables

Description of monitoring variables:

Item	Descriptions
Variable Code	Each monitoring variable has a code. Set the code via P0-02 so that the users can monitor the variable.
Format	Every monitoring variable is saved with the format of 32-bit (long integer) in the servo drive.
Classification	It is divided into basic variables and extension variables: <ol style="list-style-type: none"> <li>1. Basic variables: Use the Monitor Mode on the panel to find the variable (variables in the cycle) by pressing <b>UP</b>/<b>DOWN</b> Key (P0-02 = 0~26)</li> <li>2. Extension variables: Variables other than the basic ones (P0-02 = 27~127)</li> </ol>
Monitor Method	Two methods, Panel display and Mapping: <ol style="list-style-type: none"> <li>1. Panel display: View through the panel directly</li> <li>2. Mapping: Correspond the variables to the system parameters and view the variables via parameters.</li> </ol>
Panel Display	<ol style="list-style-type: none"> <li>1. Switch to the Monitor Mode by pressing the <b>MODE</b> Key and select the desired monitoring variables via <b>UP</b>/<b>DOWN</b> Key.</li> <li>2. Directly enter the desired monitoring code via P0-02 for viewing. Pressing the <b>SHF</b> Key on the panel can switch the display of high / low word; Pressing the <b>SET</b> Key on the panel can switch the display of decimal / hexadecimal format.</li> </ol>
Mapping	<ol style="list-style-type: none"> <li>1. Mapping parameters that support monitoring variable are P0-09 ~ P0-13. Please refer to Chapter 8.3 for parameter description.</li> <li>2. Monitoring variables can be read via communication by mapping parameters.</li> <li>3. The value of mapping parameters (P0-09~P0-13) is the content of basic variables (17h, 18h, 19h, 1Ah). The setting value which is set by P0-17 should be monitored via p0-09 (refer to p0-02). When accessing data via communication, the value of P0-17 can be read or monitored via panel (Set P0-02 to 23). When the panel shows 「VAR-1」, it means it is the value of P0-09.</li> </ol>

The descriptions of monitoring variables attribute are as the following.

Attribute	Descriptions
<b>B</b>	BASE: basic variables. Variables that can be viewed by <b>UP</b> / <b>DOWN</b> Key on the panel.
<b>Dn</b>	When the panel displays, the position of the decimal point will be <b>D1</b> which means it only shows one decimal point; <b>D2</b> means it shows two decimal points.
<b>Dec</b>	When the panel displays, the information only can be shown in decimal format. Pressing the <b>SET</b> Key on the panel cannot switch it to hexadecimal format.
<b>Hex</b>	When the panel displays, the information only can be shown in hexadecimal format. Pressing the <b>SET</b> Key on the panel cannot switch it to decimal format.

Explanation of monitoring variables:

Code	Name of Variables / Attribute	Descriptions
000 (00h)	Feedback position (PUU) <b>B</b>	The current feedback position of the motor encoder. The unit is PUU (user unit).
001 (01h)	Position command (PUU) <b>B</b>	The current coordinate of position command. The unit is PUU (user unit). PT mode: it represents the pulse number the servo drive received. PR mode: the value of absolute coordinate from position command Equals to the pulse number sent by the controller.
002 (02h)	Position deviation (PUU) <b>B</b>	The deviation between the position command and feedback position. The unit is PUU (user unit).
003 (03h)	Feedback position (pulse) <b>B</b>	Current feedback position of the motor encoder. The unit is pulse (encoder unit).
004 (04h)	Position command (pulse) <b>B</b>	The current coordinate of the position command. The unit is pulse (encoder unit). The command that had gone through E-gear.
005 (05h)	Position deviation (pulse) <b>B</b>	The deviation between the position command and feedback position. The unit is pulse (encoder unit).
006 (06h)	Pulse command frequency <b>B</b>	Frequency of pulse command received by the servo drive. The unit is Kpps. It is suitable in PT/PR mode.
007 (07h)	Speed feedback <b>B D1 Dec</b>	Current speed of the motor. The unit of rotary motor is 0.1 r/min. The value is more stable since it has been through low-pass filter.
008 (08h)	Speed command (analog) <b>B D2 Dec</b>	The speed command is issued by analog. The unit is 0.01 Volt.
009 (09h)	Speed command (processed) <b>B</b>	The processed speed command. The source might be analog, register or position loop.
010 (0Ah)	Torque command (analog) <b>B D2 Dec</b>	The torque command is issued by analog. The unit is 0.01 Volt.
011 (0Bh)	Torque command (processed) <b>B</b>	The processed torque command. The unit is percentage (%). The source might be analog, register or speed loop.
012 (0Ch)	Average load <b>B</b>	Average load output by the servo drive. The unit is percentage (%).
013 (0Dh)	Peak load <b>B</b>	The maximum load output by the servo drive. The unit is percentage (%).
014 (0Eh)	DC Bus voltage <b>B</b>	Capacitor voltage after rectification. The unit is Volt.



Code	Monitoring Variables / Attribute	Explanation
015 (0Fh)	Inertia ratio <b>B</b> <b>D1</b> <b>Dec</b>	Ratio of load inertia and motor inertia. The unit is 0.1 times.
016 (10h)	IGBT temperature <b>B</b>	IGBT temperature. Unit is °C.
017 (11h)	Resonance frequency <b>B</b> <b>Dec</b>	Resonance frequency of the system, including 2 groups of frequency, F1 and F2. When monitoring via panel, pressing <b>SHF</b> can switch the display of both: F2 shows no decimal point while F1 shows one. When reading through communication (mapping parameter): Low-16 Bit (Low WORD) returns frequency F2. High-16 Bit (High WORD) returns frequency F1.
018 (12h)	Z phase offset <b>B</b> <b>Dec</b>	The offset between the motor position and Z phase. The range is from -5000 to +5000. If the position is the same as Z phase, its value is 0. The bigger the value is, the more the offset will be.
019 (13h)	Mapping parameter #1 <b>B</b>	Return the value of parameter P0-25 which is mapped by P0-35.
020 (14h)	Mapping parameter #2 <b>B</b>	Return the value of parameter P0-26 which is mapped by P0-36.
021 (15h)	Mapping parameter #3 <b>B</b>	Return the value of parameter P0-27 which is mapped by P0-37.
022 (16h)	Mapping parameter #4 <b>B</b>	Return the value of parameter P0-28 which is mapped by P0-38.
023 (17h)	Mapping monitoring variable #1 <b>B</b>	Return the value of parameter P0-09 which is the monitoring variables mapped by P0-17.
024 (18h)	Mapping monitoring variable #2 <b>B</b>	Return the value of parameter P0-20 which is the monitoring variables mapped by P0-18.
025 (19h)	Mapping monitoring variable #3 <b>B</b>	Return the value of parameter P0-11 which is the monitoring variables mapped by P0-19
026 (1Ah)	Mapping monitoring variable #4 <b>B</b>	Return the value of parameter P0-12 which is the monitoring variables mapped by P0-20.
028 (1Ch)	Alarm codes	Alarm codes of DMCNET mode (It is applicable to A2-F, A2-N, A2-M/U/L)
029 (1Dh)	Feedback of auxiliary encoder (PUU)	The position feedback from auxiliary encoder (CN5) (It is applicable to A2-F)
030 (1Eh)	Position error of auxiliary encoder (PUU)	Position deviation between position feedback (from CN5) and command (It is applicable to A2-F)
031 (1Fh)	Position error or main/auxiliary encoder (PUU)	Feedback position deviation between main encoder and auxiliary encoder (It is applicable to A2-F)

Code	Name of Variables / Attribute	Description
035 (23h)	Indexing coordinate command	The current command of the indexing coordinates. The unit is PUU (user unit).
037 (25h)	Compare data of COMPARE	Display the compare data. This actual compare data is a compare value plus an offset value via P1-23 and P1-24. CMP_DATA = DATA_ARRAY[*] + P1-23 + P1-24
038 (26h)	Voltage level of battery	The voltage level of battery for an absolute encoder.
039 (27h)	DI status (Integrated) <b>Hex</b>	The processed DI status of the servo drive. Each bit corresponds to one DI channel. The source includes hardware channel / software P4-07 which is determined by P3-06.
040 (28h)	DO status (Hardware) <b>Hex</b>	The real status of Digital Output hardware. Each bit corresponds to one DI channel.
041 (29h)	Drive Status	Return the value of P0-46. Please refer to the description of the parameter.
043 (2Bh)	CAP, data capturing	The Data captured by CAP hardware from the latest time Note: CAP could continuously capture many points.
048 (30h)	Auxiliary encoder CNT	The value of pulse counter from auxiliary encoder (CN5)
049 (31h)	Pulse command CNT	The value of pulse counter from pulse command (CN1)
050 (32h)	Speed command (processed) <b>D1 Dec</b>	The processed speed command. The unit is 0.1 r/min. The source might be analog, register or position loop.
051 (33h)	Speed feedback (immediate) <b>D1 Dec</b>	Current actual speed of the motor. The unit is 0.1 r/min.
052 (34h)	Speed feedback (filter) <b>D1 Dec</b>	Current actual speed of the motor. The unit is 0.1 r/min.
053 (35h)	Torque command (processed) <b>D1 Dec</b>	The processed torque command. The unit is 0.1 percent (%). The source might be analog, register or speed loop.
054 (36h)	Torque feedback <b>D1 Dec</b>	Current actual torque (force) of the motor. The unit is 0.1 percent (%).
055 (37h)	Electric current feedback <b>D2 Dec</b>	Current actual electric current of the motor. The unit is 0.01 ampere (Amp).
056 (38h)	DC Bus voltage <b>D1 Dec</b>	Capacitor voltage after rectification. The unit is 0.1 volt.
059 (3Bh)	Pulse from E-Cam master axis (accumulation)	The accumulative pulse number of E-Cam master axis. It is the same as P5-86. A2L does not support this function.

Code	Monitoring Variables / Attribute	Explanation
060 (3Ch)	Pulse from E-Cam master axis (increment)	The incremental pulse number from master axis. The unit is pulse number per msec. A2L does not support this function.
061 (3Dh)	Pulse from E-Cam mast axis (lead pulse)	The lead pulse of E-Cam master axis which is used to judge the engaging condition. When it is disengaged: lead pulse = P5-87 or P5-92. When it is engaged: lead pulse = P5-89. When the value is 0, it will be disengaged. A2L does not support this function.
062 (3Eh)	The position of E-Cam axis	The position of E-Cam axis. Unit: The pulse is from the master axis. When the incremental pulse from master axis is P, the axis rotates M cycle (P5-83 = M, P5-84 = P). A2L does not support this function.
063 (3Fh)	Position of E-Cam slave axis	The position of E-Cam slave axis. Unit: PUU A2L does not support this function.
064 (40h)	Terminal register of PR command	In PR mode, the termination of position command (Cmd_E)
065 (41h)	Output register of PR command	In PR mode, the accumulative output of position command
067 (43h)	PR target speed	The target speed of path command in PR mode. The unit is PPS (Pulse Per Second)
068 (44h)	S-curve filter (input)	The input commands of S-curve filter which is used to smooth the input command. It is effective in PR mode, E-Cam and speed command. A2L does not support this function.
069 (45h)	S-curve filter (output)	The output commands of S-curve filter which is used to smooth the output command. It is effective in PR mode, E-Cam and speed command. A2L does not support this function.
072 (48h)	Speed command (analog) B D1 Dec	The speed command is issued via analog. The unit is 0.1 r/min. This function is supported by A2-M/U/L.
076 (4Ch)	Speed command of PR contour	In PR mode, the programmed trapezoid speed curve is determined by the target speed, acceleration, deceleration and moving distance (before S-curve filter). The unit is PPS (Pulse Per Second).
081 (51h)	Synchronous capture axis Incremental input pulse	When synchronous capture axis is enabled, the received pulse number between two captures can be used to measure the real distance of Mark.
082 (52h)	PR number that is currently executed	To inform HMC the PR number that is being executed (It is applicable to A2-F)
084 (54h)	Synchronous capture axis Deviation pulse number	The deviation between the real output pulse and the target pulse when synchronous capture axis is enabled. If it reaches the synchronization, the value will close to 0.

Code	Name of Variables / Attribute	Description
091 (5Bh)	The feedback of indexing coordinate	The immediate feedback position of indexing coordinates. The unit is PUU (user unit).
096 (60h)	Firmware version <b>Dec</b>	It includes two versions, DSP and CPLD. When monitoring via panel, pressing the <b>SHF</b> Key can switch the display of both: DSP shows no decimal point while CPLD shows one. When reading through communication (parameter mapping): Low-16 Bit (Low WORD) returns DSP version number. High-16 Bit (High WORD) returns CPLD version number.
098 (62h)	PLC scan time	The update time of DI/DO. The unit is 0.5 msec.
109 (6Dh)	The amount of data array	Returns the amount of data array. The unit is DWORD (32 Bits)
111 (6Fh)	Error code of the servo drive	Error code of the servo drive: only for the control loop, not including the motion controller.
112 (70h)	CANopen SYNC TS (hasn't been through the filter)	The time the servo drive receives SYNC signal (TimeStamp) The unit is usec.
113 (71h)	CANopen SYNC TS (has been through the filter)	The time the servo drive receives SYNC signal and has been through the filter. The unit is usec.
114 (72h)	CANopen timing synchronization	To synchronize the device timing with the controller during the operation. The unit is usec.
116 (74h)	The differential between position and Z phase of auxiliary encoder (pulse)	The differential between the current position and Z phase position of auxiliary encoder (It is applicable to A2-F)
120 (78h)	DMCNET connection status	DMCNET connection status (It is applicable to A2-F, A2-N)
121 (79h)	The PDO packet of DMCNET is lost during transmission	Accumulative number of the lost DMCNET PDO packet (It is applicable to A2-F, A2-N) Format: chAchB   chB   chA For example, 459010 = 0x070102      chAchB <sub>error</sub> = 7, chB <sub>error</sub> = 1, chA <sub>error</sub> = 2
123 (7Bh)	The returned value when monitoring via panel	The returned value when monitoring via panel

## 7.2.2 Description of Data Array

Many functions of motion control, such as CAPTURE, COMPARE and E-Cam (A2L does not support E-Cam function) are the data that needs to be saved in large amount of memory space, therefore, the servo drive reserves a continuous internal space to satisfy the need. The main feature of the data array is as the followings:

Feature Introduction of Data Array	
Usage	<ul style="list-style-type: none"> <li>● Save the captured data of CAPTURE</li> <li>● Save the compared value of COMPARE</li> <li>● Save the contour table of E-Cam</li> </ul> <p>Note:</p> <ol style="list-style-type: none"> <li>1. The system does not partition off the data array into the individual space of CAP, CMP and E-Cam. The user could program it according to the demand. Therefore, the space might be overlapped. Please pay close attention to it when using.</li> <li>2. A2L does not support E-Cam function.</li> </ol>
Size of Data Array	<ul style="list-style-type: none"> <li>● 32-bit integer x 800 (refer to P5-10)</li> <li>● Each data has its corresponding address. Specify the address is a must when reading or writing the data.</li> <li>● The 800 data is from 0 to 799.</li> </ul>
Data Retained	<ul style="list-style-type: none"> <li>● Manually set up the saving (P2-08 = 30, 35) is a must and the data should be saved in EEPROM of the servo drive.</li> <li>● Save the data when it is Servo Off.</li> <li>● The data will be loaded into data array automatically when it is Servo On.</li> </ul>
Accessing Window	<ul style="list-style-type: none"> <li>● Should be access via parameter P5-10 ~ P5-13.</li> </ul>

The content of the data array cannot be read or wrote directly, reading or writing the data must via parameter P5-10 ~ P5-13. The description of the parameters is as the followings:

Description of Related Parameter about Data Array		
Parameter	Name	Description
P5-10	Size of data array	Return the size of data array (read-only)
P5-11	Reading / writing address	Set the desired address of reading and writing
P5-12	Reading / writing window #1	<p>Read via panel: After reading the content of P5-11, the value of P5-11 will not change.</p> <p>Write via panel: After writing the content of P5-11, the value of P5-11 will increase 1 automatically.</p> <p>-----</p> <p>Read via communication: After reading the content of P5-11, the value of P5-11 will increase 1 automatically.</p> <p>Write via communication: After writing the content of P5-11, the value of P5-11 will increase 1 automatically.</p>

P5-13	Reading / writing window #2	<p>Read via panel: After reading the content of P5-11, the value of P5-11 will increase 1 automatically.</p> <p>Write via panel: It cannot be written via panel.</p> <p>-----</p> <p>Read via communication: After reading the content of P5-11, the value of P5-11 will increase 1 automatically.</p> <p>Write via communication: After writing the content of P5-11, the value of P5-11 will increase 1 automatically.</p>
-------	-----------------------------	--

Set the desired reading / writing address via P5-11 first. Then, read / write P5-12 or P5-13 in order to access the content of data array. If users desire to continuously write 3 data, 100, 200, 300 into the address of data array, 11, 12 and 13, the operation step is as follows:

**A. Write via panel:** Use P5-12 (reading / writing window #1), since P5-13 does not support writing via panel:

1. Set address: Set P5-11 to 11 (The first written address)
2. Write into data: Set P5-12 to 100 (After writing 100 into address 11 in data array, the value of P5-11 will increase 1 automatically.)  
Set P5-12 to 200 (After writing 200 into address 12 in data array, the value of P5-11 will increase 1 automatically.)  
Set P5-12 to 300 (After writing 300 into address 13 in data array, the value of P5-11 will increase 1 automatically.)

The last step is to read address 11, 12 and 13 and check if the content is the value that just wrote into.

**B. Read via panel:** Use P5-13 (reading / writing window #2) so as to continuously read the content.

1. Set address: Set P5-11 to 11 (The first read address)
2. Read the data: When the panel displays P5-13,  
Press the **SET** Key for the first time and show the content of address 11.  
Then, press the **MODE** Key to exit.  
Press the **SET** Key for the second time and show the content of address 12. Then, press the **MODE** Key to exit.  
Press the **SET** Key for the second time and show the content of address 13. Then, press the **MODE** Key to exit.

Note: Every time when reading the data via P5-13, the value of P5-11 will increase 1 automatically. Thus the user could continuously read the data.

If reading the data via P5-12, then the value of P5-11 will not change. The user is unable to read the next data automatically.

If users desire to read / write the data array via communication, the operation procedure is similar to panel. Moreover, the function of P5-12 and P5-13 is the same. If users desire to write 6 data, 100, 200, 300, 400, 500 and 600 into the address of data array via Modbus communication command 0x10 (continuous writing), the content of the issued command is as the followings:

Content of Communication Command: Write into Data Array									
No.	Command	Start Add.	Written Amount	P5-11		P5-12		P5-13	
				Low Word	High Word	Low Word	High Word	Low Word	High Word
1	0x10	P5-11	6 (Word)	11	0	100	0	200	0
				The first address		The first data		The second data	
2	0x10	P5-11	6 (Word)	13	0	300	0	400	0
				The third address		The third data		The fourth data	
3	0x10	P5-11	6 (Word)	15	0	500	0	600	0
				The fifth address		The fifth data		The sixth data	

If users desire to read the value of data array in order to check the previous written content, users can write the desired reading start address into P5-11 via MODBUS communication command 0x06 (write 1 data). The issuing communication command is as the following:

Content of Communication Command: Set the Reading Address of Data Array			
No.	Command	Start Add.	Written Data
4	0x06	P5-11	11

Then, read the content of specified address by communication command 0x03 (continuous reading). The issuing communication command is as follows:

Content of Communication Command: Read Data Array				Return Data					
No.	Command	Start Add.	Read Amount	P5-11		P5-12		P5-13	
				Low Word	High Word	Low Word	High Word	Low Word	High Word
5	0x03	P5-11	6 (Word)	11	0	100	0	200	0
				Read address		Data of address 11		Data of address 12	
6	0x03	P5-11	6 (Word)	13	0	300	0	400	0
				Read address		Data of address 13		Data of address 14	
7	0x03	P5-11	6 (Word)	15	0	500	0	600	0
				Read address		Data of address 15		Data of address 16	

The return value on the right-hand side of the above table represents the read parameter, P5-11, P5-12 and P5-13, which is also the content of address 11~16 in data array.

### 7.3 Description of Motion Axes

The motion axis is an internal counter of the servo drive. It is used for counting the absolute position of the axis (32-bit integer). The following motion axes are included in this servo drive:

Name of the Axis	Description	Access	Attribute
1. Main Encoder (P5-16)	It represents the absolute feedback position of the motor. The unit is PUU (user unit).	R	Physical Axis
2. Auxiliary Encoder (P5-17)	It is counted by the pulse signal from CN5 and usually connects to the second encoder or linear scale. Its pulse is A/B type.	R/W	Physical Axis
3. Pulse Command (P5-18)	It is counted by the pulse signal from CN1 and usually connects to the pulse command of the controller. The pulse type could be set by P1-00.	R/W	Physical Axis
4. Capture Axis (P5-37)	It is the axis which has CAP function. Its command source could be the above mentioned axis 1~3, which can write the new value into it and has an offset from the physical axis. Moreover, after capturing the first point, the axis position can be redefined.	R/W	Functional Axis
5. Compare Axis (P5-57)	It is the axis which has CMP function. Its command source could be the above mentioned axis 1~4, which can write the new value into it and has an offset from the physical axis.	R/W	Functional Axis
6. Master Axis (P5-86)	It is the master axis of E-Cam. Its command source could be the above mentioned axis 2, 3, 4 and 7, which can write the new value into it and has an offset from the physical axis.	R/W	Functional Axis
7. Command Axis in PR Mode	The command position is from the path generator in PR mode.	R	Virtual Axis
8. Internal Time Axis	It is the internal accumulative time counter of the servo drive. The value increases 1 every 1ms.	R	Virtual Axis
9. Synchronous Capture Axis (P5-77)	It is similar to Capture Axis (P5-37); however, it automatically adjusts the incremental pulse between two CAPs to the setting value of P5-78.	R/W	Virtual Axis

**Note:** Physical Axis: The position value is counted from the actual hardware signal.

**Functional Axis:** It is the virtual axis which has been processed by the physical. The value might not be the same as the source of physical axis. However, the incremental value is the same as the one in physical axis.

**Virtual Axis:** The axis position comes from the internal firmware of the servo drive. The command axis of PR mode is not instantaneous; therefore, it cannot be the command source axis of CAP and CMP function. However, it could be the command source of master axis of E-Cam.



## 7.4 Description of PR Mode

PR Procedure: It is the smallest unit of command. Command could be one or many procedures to constitute.

Procedure is triggered by DI.CTRG. POS0~POS5 is used to specify the triggered procedure number.

The triggered procedure is completed and will trigger the next one automatically. The procedure number can be set and the delay time between procedures as well.

The E-Cam function is provided in PR mode. It can be enabled via PR procedure. After it is disabled, it can return to the specified PR procedure.

## 7.5 The Difference between General PR Mode and the One in ASDA-A2

	General PR Mode	PR Mode in A2R
Command Number	8	64
Command Type	Positioning Command	Positioning / Constant speed Command PR jump, write in parameters
Position Command Parameter	<ul style="list-style-type: none"> <li>● Absolute or incremental</li> <li>● Acceleration/Deceleration time x 1 set</li> <li>● Motion speed x 8 sets</li> <li>● Delay time x 8 sets</li> </ul>	<ul style="list-style-type: none"> <li>● Absolute / incremental can be set individually</li> <li>● Acceleration/Deceleration time x 16 sets</li> <li>● Motion speed x 16 sets</li> <li>● Delay time x 16 sets</li> </ul>
Command Triggering Time	It has to wait until DO.ZSPD is ON	Anytime will do. It could specify the next command issuing method (in sequence / interrupt / overlap)
Command Triggering Method	<ul style="list-style-type: none"> <li>● Use DI.CTRG + POSn</li> </ul>	<ul style="list-style-type: none"> <li>● Use DI.CTRG + POSn</li> <li>● Event trigger: DI.Event + CAP complete</li> <li>● P5-07, fill in PR number to trigger.</li> </ul>
Position Command PROFILE	<ul style="list-style-type: none"> <li>● Trapezoid curve with S-curve filter (If S-curve is not enabled, then it has no function of acceleration / deceleration)</li> </ul>	<ul style="list-style-type: none"> <li>● Trapezoid curve with S-curve filter (Trapezoid curve and S-curve can be set individually.)</li> </ul>
Format of Position Command	<ul style="list-style-type: none"> <li>● Two register for turns and pulse within one turn respectively.</li> </ul>	<ul style="list-style-type: none"> <li>● PUU (32bit)</li> </ul>
Homing Function	<ul style="list-style-type: none"> <li>● The function is enabled automatically when the power is On. (Servo ON for the first time)</li> <li>● Use DI.SHOM to trigger</li> </ul>	<ul style="list-style-type: none"> <li>● The function is enabled automatically when the power is On. (Servo ON for the first time)</li> <li>● Use DI.SHOM to trigger</li> <li>● PR 0 = Homing</li> <li>● After homing is completed, the specified PR will be executed automatically.</li> </ul>
Software limit protection	No	Yes

## 7.6 The Position Unit of PR Mode

The position data of PR mode is represented by PUU (Pulse of User Unit). It is also the proportion between the controller position unit and the internal position unit of the servo drive, which is the so-called electronic gear ratio of the servo drive.

1. The position unit of the servo drive (pulse): Encoder unit: 1280000 (pulse/rev), which will not change.
2. User unit (PUU): The unit of the controller.  
P pulse per revolution (PUU/rev), the gear ratio should set as:

$$\text{GEAR\_NUM (P1-44)} / \text{GEAR\_DEN (P1-45)} = 1280000 / P$$

## 7.7 Description of Register in PR Mode

1. Position register of PR mode: All is represented in PUU (Pulse of User Unit).
2. Command register (monitoring variable 064): Command termination register Cmd\_E. It represents the absolute terminal coordinate of position command.
3. Command output register (monitoring variable 001): Cmd\_O; it represents the absolute coordinate from the current output command.
4. Feedback register (monitoring variable 000): Fb\_PUU; it shows the absolute feedback position of the motor.
5. Deviation register (monitoring variable 002): Err\_PUU; it is the deviation between the register from command output and feedback register.
6. In PR mode, either in operation or stop status, it satisfies the condition of  $\text{Err\_PUU} = \text{Cmd\_O} - \text{Fb\_PUU}$ .

Influence brought by position command:

Type of Command	When issuing the command =>	=> When command is executing =>	=> Command is completed
Absolute Positioning Command	Cmd_E = command data (absolute) Cmd_O does not change. DO.CMD_OK is OFF	Cmd_E does not change. Cmd_O continuously output ...	Cmd_E does not change. Cmd_O = Cmd_E DO.CMD_OK is ON
Incremental Positioning Command	Cmd_E+= command data (incremental) Cmd_O does not change. DO.CMD_OK is OFF	Cmd_E does not change. Cmd_O continuously output ...	Cmd_E does not change. Cmd_O = Cmd_E DO.CMD_OK is ON
Issue the command of DI : STP to stop the command	Cmd_E does not change. Cmd_O continuously output DO.CMD_OK is unchangeable	Cmd_E does not change. Cmd_O stops according to the deceleration curve	Cmd_E does not change. Cmd_O = position after stop DO.CMD_OK is ON

Type of Command	When issuing the command =>	=> When command is executing =>	=> Command is completed
anytime			
Homing Command	Cmd_E does not change. Cmd_O does not change. DO.CMD_OK is OFF DO.HOME is OFF	Cmd_E continuously output Cmd_O continuously output ... ...	Cmd_E = the absolute position of Z Cmd_O = position after stop DO.CMD_OK is ON DO.HOME is ON
Speed Command	Cmd_E continuously output. Cmd_O continuously output. When the speed command is completed, it means the speed reaches the setting value and does not stop. DO.CMD_OK is OFF		
Enter PR (Servo Off->On or switch the mode and enter into PR mode)		Cmd_O = Cmd_E = current feedback position	
Note: The incremental positioning command is accumulated by command termination Cmd_E. It is neither related to the current position of the motor nor the command time.			

## 7.8 Homing Description of PR Mode

The purpose of homing is to connect the Z pulse position of motor encoder to the internal coordinate of the servo drive. The coordinate value corresponded by Z pulse can be specified.

After homing is completed, the stopped position will not be the Z pulse. It is because it has to decelerate to stop when finding the Z pulse. It might therefore exceed a bit. However, since the position of Z pulse has correctly setup, it would not influence the accuracy of positioning. For example, when specifying the coordinate value corresponded by Z pulse is 100 and it is  $\text{Cmd\_O} = 300$  after homing, it means the deceleration distance is  $300 - 100 = 200$  (PUU). Since  $\text{Cmd\_E} = 100$  (Z's absolute coordinate), if desire to return to Z pulse position, issuing the positioning command will do, absolute 100 command or incremental 0 command.

After homing is completed, it will execute the specified PR automatically, which can move a distance of offset after homing.

When it is executing homing, software limit is disabled.

### 7.9 DI / DO Provided by PR Mode and Diagrams

DI signal:

CTRG, SHOM, STP, POS 0~5, ORG, PL (CCWL), NL (CWL), EV1~4

DO signal:

CMD\_OK, MC\_OK, TPOS, ALM, CAP\_OK, CAM\_AREA

System frame:

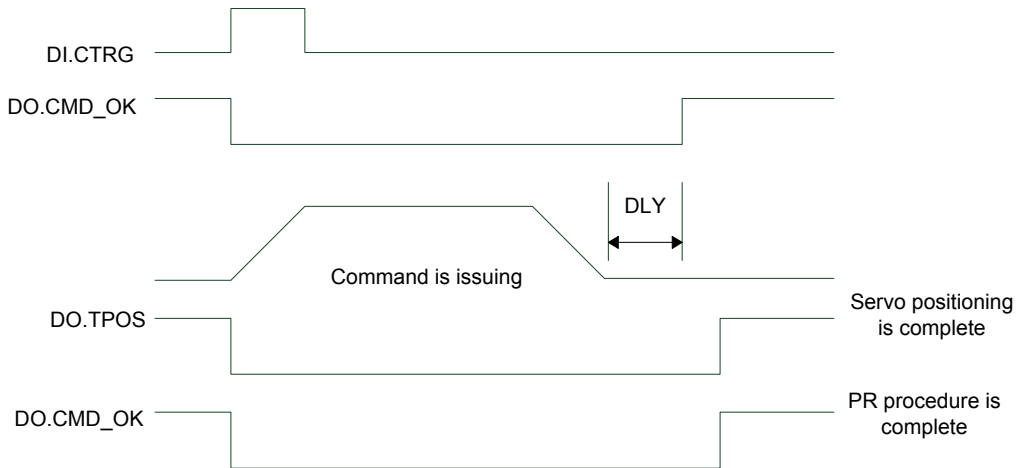

Description of command triggered method in PR mode:

64 command procedures are in each axis of PR mode. Procedure #0 is homing and the others (#1~#63) are the procedures that users can self-define. The command triggered method is concluded as the followings:

	Command Source	Description
Standard trigger	DI.CTRG + POS0 ~ 5	Use DI.POS0 ~ 5 to trigger the desired procedure number. Then, use the rising edge of DI.CTRG to trigger PR command. Application: PC or PLC that issues command via DI
Functional trigger	DI.STP, SHM	When DI.STP is from OFF → ON, the command stops in half way. When DI.SHOM is from OFF → ON, it starts homing.
Event trigger	DI.EV1~4	The change status of DI.EV1 ~ 4 can be the triggered event. Set the triggered procedure number from OFF → ON by parameter P5-98. Set the triggered procedure number from ON → OFF by parameter P5-99. Application: connect to the sensor and trigger the preset procedure.
Software trigger	P5-07	Directly write the procedure number into P5-07 and trigger command. Both panel and communication (RS-232/485 / CANopen) can do. Application: PC or PLC that issues command via

		communication.
Other	CAP trigger E-CAM disengage trigger	After the capture is completed, procedure #50 can be triggered and activated by the setting value Bit3 of P5-39 X. When E-cam is disengaged and returns to PR mode, the procedure specified by P5-88 BA setting value can be triggered. A2L does not support E-Cam function.

## 7.10 Parameter Settings

1) Target speed: P5-60 ~ P5-75, 16 PR in total

Bit	15 ~ 0-bit
W0	TARGET_SPEED: 0.1 ~ 6000.0(r/min)

2) Accel / Decel time: P5-20 ~ P5-35, 16 PR in total

Bit	15 ~ 0
W0	T_ACC / T_DEC: 1 ~ 65500 (msec)

Note: The deceleration time used by DI: STP/EMS/NL(CWL)PL(CCWL) is defined via P5-07.

3) Pause time: P5-40 ~ P5-55, total 16 PR in total

Bit	15 ~ 0
W0	IDLE : 0 ~ 32767(msec)

4) PR parameters: P5-00 ~ P5-09, P6-00 ~ P6-01, 12 DWORD in total

	32-bit
P5-00	Reserved
P5-01	Reserved (It is for testing only, do not use)
P5-02	Reserved (It is for testing only, do not use)
P5-03	Deceleration time of auto protection
P5-04	Homing mode
P5-05	1 <sup>st</sup> Speed setting of high speed homing
P5-06	2 <sup>nd</sup> Speed setting of low speed homing
P5-07	PR command register
P5-08	Forward software limit
P5-09	Reverse software limit
P6-00	Homing setting
P6-01	Origin definition

Note: Path (procedure)

5) PR Definition: P6-02 ~ P7-27, (64-bit), 63 sets of PR in total (2N)

Bit	31 ~ 28	27 ~ 24	23 ~ 20	19 ~ 16	15 ~ 12	11 ~ 8	7 ~ 4	3 ~ 0
DW0	...	...	...	...	...	...	...	TYPE
DW1	DATA (32-bit)							

Each PR has two parameters; the PR function is determined by TYPE. DATA represents position or speed data while the others are the additional information.

## 6) SPEED, Constant speed control: TYPE = 1

Bit	31 ~ 28	27 ~ 24	23 ~ 20	19 ~ 16	15 ~ 12	11 ~ 8	7 ~ 4	3 ~ 0
DW0	-	-	DLY	-	DEC	ACC	OPT	1
DW1	DATA (32 bit): Target speed. Unit: Defined by OPT.UNIT							

When this command is executing, the motor accelerates or decelerates from the current speed until it reaches the target speed. After the command is completed, the motor will remain at the same speed and never stop.

## OPT:

OPT			
Bit 7	Bit 6	Bit 5	Bit 4
-	UNIT	AUTO	INS

※DI.STP stop and software limit are acceptable.

INS: When this PR is executing, it will interrupt the previous PR.

AUTO: When the speed reaches the constant speed area, the next PR will be loaded automatically.

UNIT: 0 unit is 0.1r/min ( $10^{-6}$ m/s for linear motor); 1 unit is PPS (Pulse Per Second)

ACC / DEC: 0 ~ F, Accel / Decel number

<b>ACC (4-bit) / DEC (4-bit)</b>	Index P5-20 ~ P5-35
----------------------------------	---------------------

SPD: 0 ~ F, target speed number

<b>SPD (4-bit)</b>	Index P5-60 ~ P5-75
--------------------	---------------------

DLY: 0 ~ F, delay time number. The delay after executing this PR. The external INS is invalid.

<b>DLY (4-bit)</b>	Index P5-40 ~ P5-55
--------------------	---------------------

## 7) POSITION, Positioning control: (TYPE = 2, PR is completed and stopped), (TYPE = 3, the next PR is executed automatically after the PR is completed)

Bit	31 ~ 28	27 ~ 24	23 ~ 20	19 ~ 16	15 ~ 12	11 ~ 8	7 ~ 4	3 ~ 0
DW0	-	-	DLY	SPD	DEC	ACC	OPT	2 or 3
DW1	DATA (32 bit): Target position, Unit: Pulse of User Unit							



OPT:

OPT				Explanation
Bit 7	Bit 6	Bit 5	Bit 4	
CMD		OVLP	INS	
0	0	-	-	Absolute position command: Cmd_E = DATA (Note 1)
1	0			Incremental position command: Cmd_E = Cmd_E + DATA (Note 2)
0	1			Relative position command: Cmd_E = Current feedback position + DATA (Note 3)
1	1			Capture position command: Cmd_E = Capture position + DATA (Note 4)

※DI.STP stop and software limit are acceptable.

INS: When this PR is executing, it will interrupt the previous PR

OVLP: It is allowed to overlap the next PR. When overlapping, please set DLY to 0.

CMD: The calculation of the position terminal command (Cmd\_E) is as the followings:

Note 1: Position terminal command is determined by DATA.

Note 2: Position terminal command is determined by the previous terminal command (Monitoring variable 40h) plus DATA.

Note 3: Position terminal command is determined by the current feedback position (Monitoring variable 00h) plus DATA.

Note 4: Position terminal command is determined by the position latched by CAP (Monitoring variable 2Bh) plus DATA.

8) Special code: TYPE = 7, jump to the specified PR.

Bit	31 ~ 28	27 ~ 24	23 ~ 20	19 ~ 16	15 ~ 12	11 ~ 8	7 ~ 4	3 ~ 0
DW0	-	-	DLY	-	FUNC_CODE	-	OPT	7
DW1	PR Number (0 ~ 63)							

OPT:

OPT			
Bit 7	Bit 6	Bit 5	Bit 4
-	-	-	INS

PATH\_NO: The jump target procedure number

FUNC\_CODE: Reserved

DLY: The delay time after jump

9) Special code: TYPE = 8, write the specified parameter.

Bit	31 ~ 28	27 ~ 24	23 ~ 20	19 ~ 16	15 ~ 12	11 ~ 8	7 ~ 4	3 ~ 0
DW0	0	S_D	DLY	DESTINATION		OPT	8	
DW1	SOURCE							

DLY: Delay time after writing the parameters

Bit28 ~ Bit31 are not 0x0, then AL213 occurs.

S\_D: Specified data source and written target.

S_D					
Bit 27	Bit 26	Bit 25	Bit 24	Explanation	
SOUR		Rsvd	DEST	Data Source	Write Destination
0	0	0	0	Constant	Parameter Px-xx
0	1		0	Parameter Px-xx	Parameter Px-xx
1	0		0	Data Array	Parameter Px-xx
1	1		0	Monitoring variable	Parameter Px-xx
0	0		1	Constant	Data Array
0	1		1	Parameter Px-xx	Data Array
1	0		1	Data Array	Data Array
1	1		1	Monitoring variable	Data Array

Rsvd is not 0, then AL213 occurs.

OPT:

OPT			
Bit 7	Bit 6	Bit 5	Bit 4
-	-	AUTO	INS

Para\_Data: the written data

INS: When executing this PR, it interrupts the previous one.

AUTO: When this PR is completed, it will execute the next PR automatically.

ROM: 1 means to write into EEPROM at the same time. (The supported written target is parameter, if the target is data array, then it will not be written into EEPROM.)

DESTINATION: Setting of the written target

	DESTINATION		
	Bit 19 ~ 16	Bit 15 ~ 12	Bit 11 ~ 8
When DEST = 0, it represents parameter, Px-xx	P_Grp	P_Idx	
When DEST = 1, it represents data array.	Array_Addr		

P\_Grp, P\_Idx: Specified parameter group and number

Array\_Addr: Position of the specified data array.

SOURCE: Settings of data source

Bit	SOURCE							
	31 ~ 28	27 ~ 24	23 ~ 20	19 ~ 16	15 ~ 12	11 ~ 8	7 ~ 4	3 ~ 0
SOUR = 00 means constant	Para_Data							
SOUR = 01 means parameter Px-xx	Rsvd (0x0000 0)					P_Grp	P_Idx	
SOUR = 10 means data array	Rsvd (0x0000 0)					Array_Addr		
SOUR = 11 means monitoring variable	Rsvd (0x0000 00)						Sys_Var	

P\_Grp, P\_Idx: specified parameter group and number

Array\_Addr: specified the position of data array

Para\_Data: the written constant

Sys\_Var: monitor parameter code. Refer to P0-02 for its setting.

When Rsvd is not 0, it will display AL.213. When P\_Grp exceeds the range, it will display AL.207.

When displaying AL.209, it means P\_Idx exceeds the range.

When Array\_Addr exceeds the range, it will display AL.213. And AL.231 is for Sys\_Var exceeding the range.

Note: 1. Even when the written parameter is retained, the new value will not be written into EEPROM. Too frequent written will not shorten the lifetime of EEPROM.

Note: The aim of writing parameters via PR procedure is for turning ON/OFF or adjusting some functions. (E.g. according to different positioning command to adjust P2-00, Position Loop Gain.) This procedure will continuously repeat during the operation. If the data is all written into EEPROM, it will shorten the lifetime of EEPROM. In addition, if P2-30 is set to 5, the modified parameters (either from panel or communication) will not be saved and is inconvenient to use. Thus, this new function is added.

3. If writing parameters fails, alarm AL.213~219 will occur (Refer to Chapter 11 of the manual) and the next PR which is enabled by AUTO function will not be executed.

10) Special Function: TYPE = 0xA, Indexing command.

Bit	31 ~ 28	27 ~ 24	23 ~ 20	19 ~ 16	15 ~ 12	11 ~ 8	7 ~ 4	3 ~ 0
DW0	-	OPT2	DLY	SPD	DEC	ACC	OPT	0xA
DW1	DATA (32-bit): Indexing Coordinate Command, Unit: PUU							

OPT:

OPT			
Bit 7	Bit 6	Bit 5	Bit 4
<p style="text-align: center;"><b>DIR</b></p> <p>00: Always move forward (Forward Rotation)                      01: Always move reverse (Reverse Rotation)                      10: Shortest distance (Judging by the current position and target position)                      11: Reserved</p>		OVLP	INS

INS: When this PR is executing, it interrupts the previous one.

OVLP: It is allowed to overlap the next PR. When overlapping, please set DLY to 0.

OPT2:

OPT2			
Bit 27	Bit 26	Bit 25	Bit 24
-	AUTO	-	S_LOW

AUTO: Position reached and the next PR is loaded automatically.

S\_LOW: Selection of speed unit. 0 means the unit is 0.1r/min; while 1 means 0.01r/min

DATA (DW1): Data format

DW1: DATA (32 bits)
PUU: 0~ (P2-52-1)

P2-52: Size of indexing coordinates

11) Homing Definition: P6-00 ~ P6-01, (64 bits) one set of PR.

Bit	31 ~ 28	27 ~ 24	23 ~ 20	19 ~ 16	15 ~ 12	11 ~ 8	7 ~ 4	3 ~ 0
DW0	BOOT	-	DLY	DEC2	DEC1	ACC	PATH	
DW1	ORG_DEF (32-bit)							

PATH (PR): 0 ~ 3F. (6 bits)

00 (Stop): Homing completed and stops

01 ~ 3F (Auto): Homing completed and executes the specified PR: 1 ~ 63.

Note: PATH (procedure)

ACC: Acceleration time

DEC1/DEC2: The first / second deceleration time

DLY: Delay time

BOOT: Activation mode. When the POWER is ON:

0: will not do homing

1: start homing (Servo ON for the first time)

ORG\_DEF: the coordinate value of the origin definition which might not be 0

1) After finding the origin (Sensor or Z), the motor has to decelerate to stop. The stop position will slightly exceed the origin. After the positioning is completed, users can determine and setup the motor position:

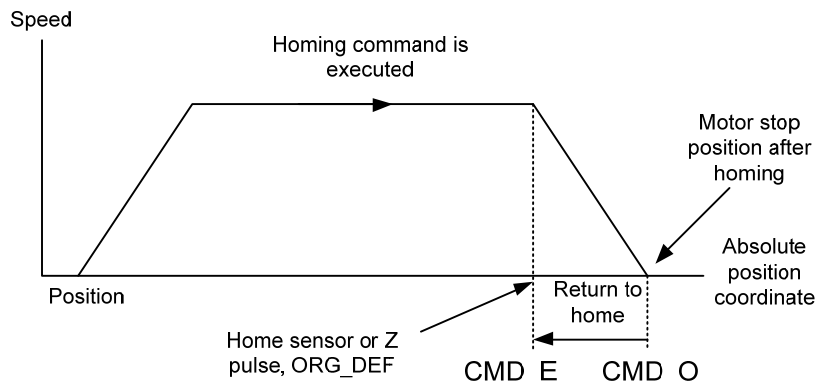

If not returning to the original point, set PATH to 0.

If desire to return to the original point, set PATH to non-zero value and setup that PR: absolute positioning command = ORG\_DEF.

CMD\_O: Command Output Position

CMD\_E: Command End Position

2) Homing does not define the offset value but uses PATH to specify a path as the offset value.

After finding the origin, if the user desires to move a short distance of offset S (the related home Sensor or Z) and set the coordinate to P after moving: (incremental positioning command = S will do)

### 7.10.1 The Relation between the Previous Path and the Next Path

1) Interrupt (the previous path) and overlap (the next path) can be set in every path

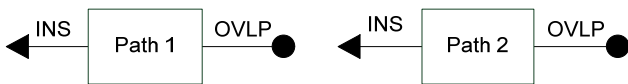

Note: Path (procedure)

2) The priority of interrupt command is higher than overlap

PATH 1	PATH 2	Relation	Output	Note
OVLP = 0	INS = 0	In sequence	DLY 1	PATH 1/2 which could be the combination of speed/position
OVLP = 1	INS = 0	Overlap	NO DLY	PATH 2 is SPEED and does not support overlap
OVLP = 0	INS = 1	Interrupt	N/A	PATH 1/2 which could be the combination of speed/position
OVLP = 1				

### 7.10.2 Programming the Path in PR Mode

1) Sequence command

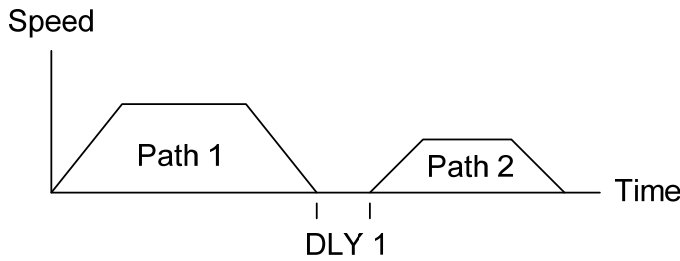

Path 1: is AUTO and has set DLY  
 Path 2: does not set INS  
 (DLY starts to count after completing the command)

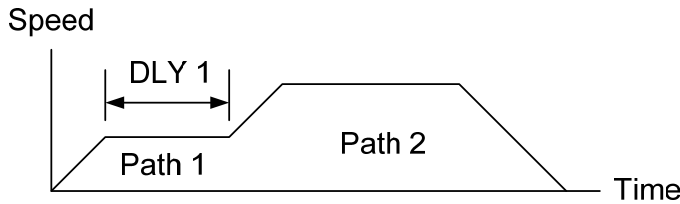

Path 1: speed command and has set DLY  
 Path 2: position command  
 (DLY starts to count after completing the command)

2) Overlap

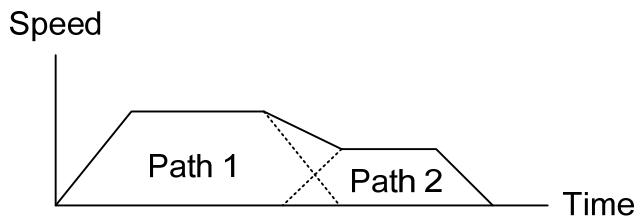

Path 1: has set OVLP but cannot set DLY  
 Path 2: does not set INS

3) Internal Interrupt

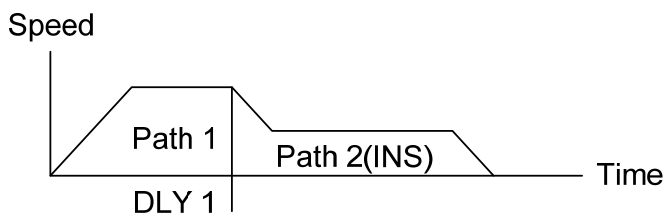

Path 1: AUTO and has set DLY  
 Path 2: has set INS  
 (DLY is effective to the internal interrupt)  
 It can be used to pre-constitute complicated Profile

4) External Interrupt

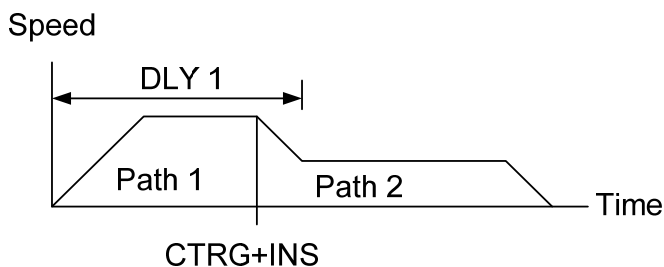

Path 1: AUTO or SINGLE  
 Regardless the setting of DLY  
 Path 2: has set INS  
 (DLY is ineffective to the external interrupt)  
 Profile can be changed from external any time

## 7.11 The Description of E-Cam Function

E-Cam is a virtual cam which is implemented by software. It includes Master axis and Slave axis. The illustration is as the following:

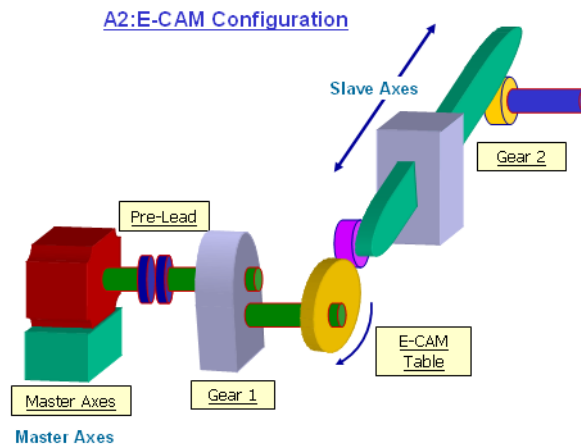

In PT mode, the position command (slave) is issued by the external pulse input (master). The two is merely the linear scaling relation (its scaling equals to e-gear ratio). However, instead of linear scaling, E-Cam is defined by cyclic curve profile, just like the cam shape. In physical machine cam, slave axis can operate as variable speed motion, alternating motion, intermittent motion, etc by master axis with the constant speed motion. It is very extensive in application. Using E-Cam could have similar effect. The following table describes the differences between E-Cam and Machine Cam.

	Machine Cam	E-Cam
Structure	Return to the original position after rotating a cycle.	It might not return to the original position after rotating a cycle. The structure could be in spiral shape like mosquito coil incense.
Smooth Performance	It is determined by the fineness of the real process.	It is interpolated by cubic curve via software
Position Accuracy	Very precise (when it has no vibration)	The command is very precise, but the actual position might have deviation due to the servo delay.
Long Distance Motion	The longer the slave axis is, the bigger the cam will be. It is not easy to make.	Change the value of the table will do. It is easy to realize.
The Necessity of Master Axis	The master axis is necessary.	The master axis is unnecessary when it is applied to constant speed motion. It will do by using the internal signal of the servo drive.
Flexibility	It is inconvenient to change and modify and it is expensive as well.	It will do by re-setting the parameter.
Maintenance	Machine will wear and the maintenance is necessary.	No need to maintain.
Others	The master axis needs space and it consumes energy as well.	Save the space and energy which protects the environment.



The main feature of E-Cam is as the followings:

Features of E-Cam	
Operation	Operate the E-cam in PR mode only.
Active the E-Cam Function P5-88.X	0: disable E-cam function and force to disengage (default). 1: enable E-cam function and starts to judge the engaged condition.
E-Cam Status	<b>Stop / Pre-engage / Engage</b>
Source of Master Axis	<ul style="list-style-type: none"> <li>● Auxiliary encoder (linear scale)</li> <li>● Pulse command</li> <li>● CAP axis (defined by CAP function)</li> <li>● PR command</li> <li>● Time axis</li> <li>● Synchronous capture axis</li> </ul>
Motion Command of the Servo Drive	<p>The overlap motion command issued by PR and E-Cam</p> $\text{Command of the Servo Drive} = \text{E-Cam command} + \text{PR command}$ <ul style="list-style-type: none"> <li>● The command will be issued only in Engaged status</li> <li>● PR command is effective regardless to the E-Cam status. Except when E-cam is engaging and the source of master axis is PR command, PR command is 0.</li> </ul> <p>When E-Cam is operating, its position still can be adjusted by PR command (incremental command in general).</p>
Data Storage Address of E-Cam table	<ul style="list-style-type: none"> <li>● It is stored in Data array and the start address is set by P5-81.</li> </ul>
Data Size of E-Cam table	<ul style="list-style-type: none"> <li>● It is set by P5-82. 720 points is the maximum and 5 points is the minimum.</li> </ul>
Data Format of E-Cam table	<ul style="list-style-type: none"> <li>● 32-bit signed value.</li> </ul>
Data Content of E-Cam table	<ul style="list-style-type: none"> <li>● Save the position of slave axis (User unit, PUU)</li> </ul>
The operation of E-Cam position	<ul style="list-style-type: none"> <li>● The master axis operates by incremental command input.</li> <li>● The slave axis issues position command incrementally.</li> <li>● The start and the end of E-Cam curve profile could not always be the same. It depends on the value of E-Cam table.</li> <li>● The command is interpolated by cubic curve. The torque on each point will be smoothly connected because of quadratic differential operation.</li> </ul>

E-Cam provided by this servo drive and below is its functional diagram:

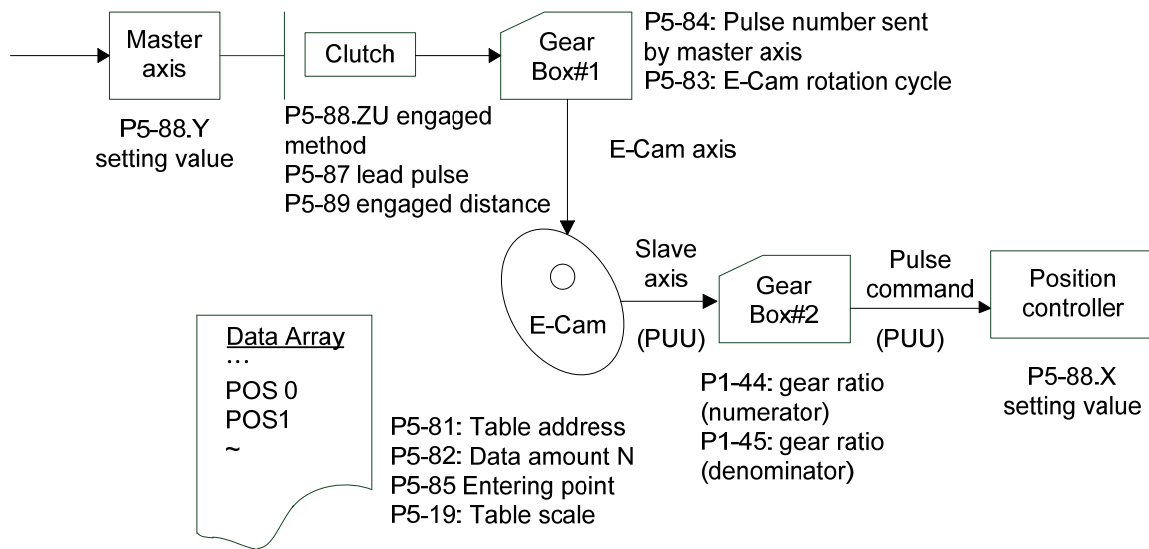

■ Master Axis, the description is as follows:

Function	The moving distance of the master axis is the source which could drive the E-Cam
Source of Master Axis The Setting Value of P5-88 Y	Source selected by P5-88.Y: <ul style="list-style-type: none"> <li>● Auxiliary encoder (linear scale)</li> <li>● Pulse command</li> <li>● PR command</li> <li>● Time axis</li> <li>● Synchronous capture axis</li> <li>● CAP axis (defined by CAP function)</li> </ul>
Position of Master Axis P5-86	The position of master axis can be monitored via P5-86. It also can be written before the E-cam engaged. To change this parameter will not influence the position of the slave. It is because the moving distance of master axis remains.

■ Clutch, the description is as follows:

Function	It is used to determine the status of engaged / disengaged between the master axis and gear box # 1. The moving distance of the master axis can drive the E-Cam not until the cam is engaged.
Activate E-cam function P5-88.X	0: disable E-cam function (default value). If the cam is engaged, the cam will be forced to disengage. 1: enable E-cam function and starts to judge the engaged condition
E-Cam Status	Status can be known via parameter P5-88.S: 0 – Stop; 1 – Engage; 2 – Pre-engage

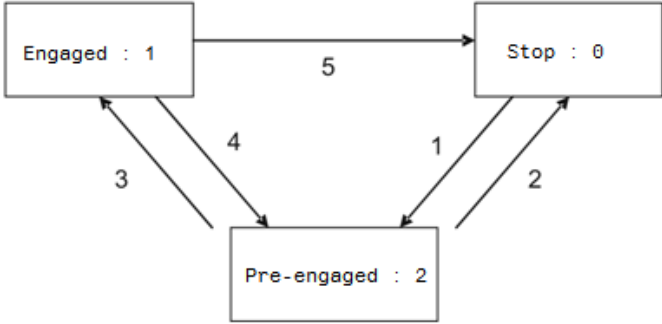
	<div style="text-align: center;">  <pre> graph TD     Engaged["Engaged : 1"] -- 5 --&gt; Stop["Stop : 0"]     Engaged -- 4 --&gt; PreEngaged["Pre-engaged : 2"]     PreEngaged -- 3 --&gt; Engaged     PreEngaged -- 2 --&gt; Stop     Stop -- 1 --&gt; PreEngaged             </pre> </div> <p><u>Status Description:</u></p> <ul style="list-style-type: none"> <li>● <b>Stop:</b> It is the initial status of the cam. The E-cam will not operate with the master pulse. When E-cam function is disabled (P5-88.X=0), it returns to this status.</li> <li>● <b>Pre-engage:</b> When the engaged condition (path 1) is established, it enters this status. The E-cam still will not operate with the master pulse.</li> <li>● <b>Engage:</b> When it reaches pre-engaged status (path 3), it enters this status. The E-cam starts to operate with the master pulse.</li> </ul> <p><u>Path Description:</u></p> <ul style="list-style-type: none"> <li>● <b>Path 1 :</b> When the engaged condition is established (P5-88.Z), the status is Stop → Pre-engaged. The lead pulse is determined by P5-87.</li> <li>● <b>Path 2 :</b> When the E-cam function is disabled (P5-88.X=0), it returns to Stop status.</li> <li>● <b>Path 3 :</b> When it is in pre-engaged status, the status is Pre-engaged → Engaged.</li> <li>● <b>Path 4 :</b> When the disengaged condition is established (P5-88.U = 4), the status is Engaged → Pre-engaged. The lead pulse is determined by P5-92. (It is available after firmware version V1.006sub04)</li> <li>● <b>Path 5 :</b> When the disengaged condition is established (P5-88.U = 1,2,6), or the E-cam function is disabled (P5-88.X = 0), the status is Engaged → Stop.</li> </ul>
<p>Engage Condition P5-88.Z</p>	<p>When the E-cam is in Stop status, the method of determine engaged (path 1) is as the following:</p> <p>0: Engaged immediately. If P5-88.X is set to 1, the engaged condition is established.</p> <p>1: When DI.CAM is ON, E-cam is engaged.</p> <p>2: From CAP to engaged: E-cam is engaged when CAP function is enabled. After engaged, it starts to count the moving distance. Since the CAP position is captured by hardware, it has good instantaneity and no software delay, which is suitable for the operating master axis before engaged.</p>

<p>Lead Pulse Monitoring Variables (061)</p>	<ul style="list-style-type: none"> <li>● In pre-engaged status, the lead pulse is the moving distance of master axis before the E-cam is engaged (path 3). Its value decreases when input the master pulse. When the value is 0, it enters Engaged status.</li> <li>● Enter Pre-engaged status via path 1, the lead pulse is determined by the value of P5-87.</li> <li>● Enter Pre-engaged status via path 4, the lead pulse is determined by the value of P5-92.</li> <li>● If the setting is 0, it means no lead pulse and will enter Engaged status immediately.</li> </ul> <p>Symbol + / - represents the direction of lead pulse. Please note that the E-cam will be unable to engage if setting the wrong direction. If setting the wrong direction, the value of monitoring variable (061) will increase, which is far from 0 and causes overflow at the end. If it overflows, the E-cam function will be disabled (P5-88.X=0) and the E-cam will be forced to return to Stop status.</p>																				
<p>Disengage Condition P5-88.U</p>	<p>When the E-cam is in Engaged status, the method of determine disengaged is as the following:                  Note: 2, 4 and 6 cannot be selected at the same time</p> <table border="1" data-bbox="475 936 1394 1776"> <thead> <tr> <th>U</th> <th>Disengage Condition</th> <th>After Disengaged</th> </tr> </thead> <tbody> <tr> <td>0</td> <td>Never disengaged. It will be forced to disengage until P5-88.X is set to 0.</td> <td><b>(Path 5)</b> Enter <b>Stop</b> Status</td> </tr> <tr> <td>1</td> <td>DI.CAM is OFF</td> <td><b>(Path 5)</b> Enter <b>Stop</b> Status</td> </tr> <tr> <td>2</td> <td>Master axis receives the pulse number which is set by P5-89 and stops immediately. (The symbol represents the direction)</td> <td rowspan="2"><b>(Path 5)</b> Enter <b>Stop</b> Status</td> </tr> <tr> <td>6</td> <td>Same as 2, the E-cam starts to decelerate when disengaging. It is suitable for the application of calling the next PR position command right after disengaged.</td> </tr> <tr> <td>4</td> <td>Master axis receives the pulse number which is set by P5-89 and stops immediately. (The symbol represents the direction)</td> <td><b>(Path 4)</b> Returns to <b>Pre-engaged</b> Status The lead pulse is P5-92</td> </tr> <tr> <td>8</td> <td>Disable the E-cam after disengaging</td> <td>Set P5-88.X = 0</td> </tr> </tbody> </table>	U	Disengage Condition	After Disengaged	0	Never disengaged. It will be forced to disengage until P5-88.X is set to 0.	<b>(Path 5)</b> Enter <b>Stop</b> Status	1	DI.CAM is OFF	<b>(Path 5)</b> Enter <b>Stop</b> Status	2	Master axis receives the pulse number which is set by P5-89 and stops immediately. (The symbol represents the direction)	<b>(Path 5)</b> Enter <b>Stop</b> Status	6	Same as 2, the E-cam starts to decelerate when disengaging. It is suitable for the application of calling the next PR position command right after disengaged.	4	Master axis receives the pulse number which is set by P5-89 and stops immediately. (The symbol represents the direction)	<b>(Path 4)</b> Returns to <b>Pre-engaged</b> Status The lead pulse is P5-92	8	Disable the E-cam after disengaging	Set P5-88.X = 0
U	Disengage Condition	After Disengaged																			
0	Never disengaged. It will be forced to disengage until P5-88.X is set to 0.	<b>(Path 5)</b> Enter <b>Stop</b> Status																			
1	DI.CAM is OFF	<b>(Path 5)</b> Enter <b>Stop</b> Status																			
2	Master axis receives the pulse number which is set by P5-89 and stops immediately. (The symbol represents the direction)	<b>(Path 5)</b> Enter <b>Stop</b> Status																			
6	Same as 2, the E-cam starts to decelerate when disengaging. It is suitable for the application of calling the next PR position command right after disengaged.																				
4	Master axis receives the pulse number which is set by P5-89 and stops immediately. (The symbol represents the direction)	<b>(Path 4)</b> Returns to <b>Pre-engaged</b> Status The lead pulse is P5-92																			
8	Disable the E-cam after disengaging	Set P5-88.X = 0																			
<p>Auxiliary Selection P5-88.BA</p>	<p>When the E-cam disengaged, if it is in the setting distance (P5-88.U=2), it returns to Stop status and can determine the execution PR number.</p>																				

■ Gear # 1, the description is as follows:

Function	<ul style="list-style-type: none"> <li>● Set the relativity of master axis and E-cam axis. E.g. The master axis operates one cycle; the E-cam axis is no need to operate one cycle.</li> </ul>
Description	<ul style="list-style-type: none"> <li>● E-cam axis is a virtual axis.</li> <li>● The E-cam axis operates one cycle (360 degrees) means the cam operates one cycle and the slave axis operates one cycle.</li> <li>● The pulse number is the unit of moving distance of the master axis. Its resolution is determined by the source.</li> </ul>
Setting Method P5-83: M P5-84: P	<ul style="list-style-type: none"> <li>● If the pulse number of master axis is P, the E-cam axis operates M cycle. Then, the setting of gear ratio is P5-83 = M, P5-84 = P</li> </ul>

■ Cam, the description is as follows:

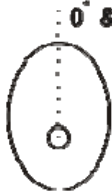
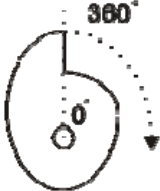
Function	<ul style="list-style-type: none"> <li>● Set the relation between E-cam axis and slave axis and define it in the E-cam table. E-cam axis operates one cycle and the slave axis operates one cycle.</li> </ul>
Data Storage Address of E-Cam table	<ul style="list-style-type: none"> <li>● Data array, the start address is set by P5-81</li> </ul>
Data Format	<ul style="list-style-type: none"> <li>● 32-bit (It has positive and negative, user unit: PUU)</li> </ul>
E-Cam Curve Scaling P5-19 0 ~ +/- 32.700	<ul style="list-style-type: none"> <li>● It is used to magnify (minify) the E-cam shape.</li> <li>● It equals to the value of data multiplies P5-19.</li> <li>● Switch the symbol, + / - will change the operation direction of slave axis.</li> <li>● If P5-19 is set to 0, the E-cam command will not be outputted. (The setting will be 0 for good).</li> </ul>
Data Size	<ul style="list-style-type: none"> <li>● It is divided into N parts via P5-82 (&gt; = 5) and does not exceed the limit of data array. It means 360 degrees a cycle of E-cam are divided into N areas. Each area is (360/N) degrees.</li> </ul>
Data Content	<ul style="list-style-type: none"> <li>● The position data of slave axis is saved in E-cam table. (User unit: PUU).</li> <li>● If E-cam is divided into N areas, the position of each area must be included in the table. It must set N + 1 points in total. It is because the position of the first point (0 degree) and the final point (360 degree) might not be the same.</li> </ul> <div style="display: flex; justify-content: space-around; align-items: flex-start;"> <div style="text-align: center;"> <p>The data of 1.0° and 360° is identical</p>  </div> <div style="text-align: center;"> <p>The data of 2.0° and 360° is different</p>  </div> </div>

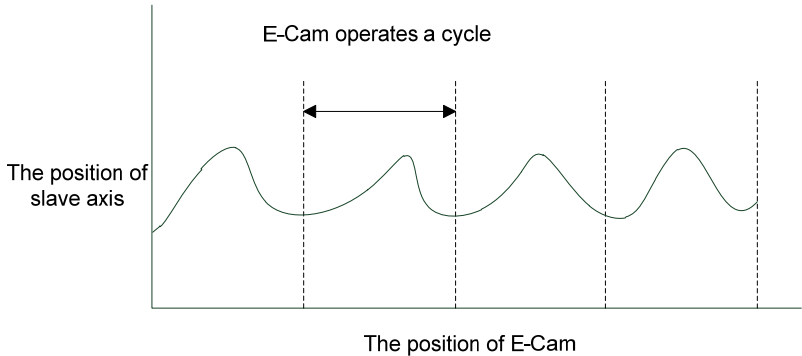
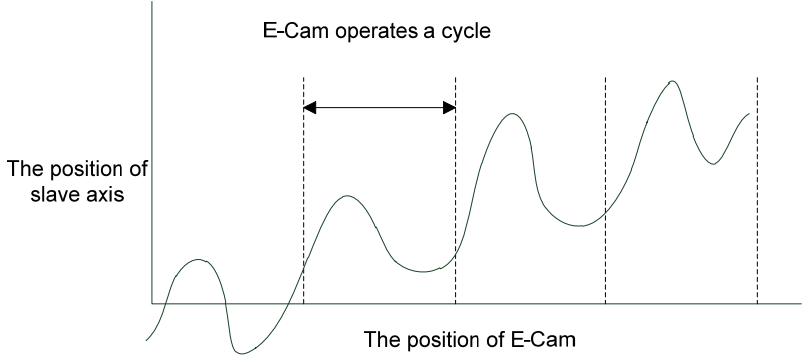
	<ul style="list-style-type: none"> <li>● If:             <ol style="list-style-type: none"> <li>1. The start and final position is the same, it means after the E-cam operating a cycle, the slave axis returns to the origin position.</li> </ol>  <p>The position of slave axis</p> <p>The position of E-Cam</p> <ol style="list-style-type: none"> <li>2. The start and final position is different, it means after the E-cam operating a cycle, the slave axis does not return to the origin position.</li> </ol>  <p>The position of slave axis</p> <p>The position of E-Cam</p> </li></ul>
Operation Description	<ul style="list-style-type: none"> <li>● The slave axis is a virtual axis and the unit of slave position is PUU.</li> <li>● After the E-cam is engaged, the position of the master is the entering point of P5-85. The position of the slave axis is in the corresponding point to the P5-85 in E-cam table.</li> <li>● After engaging, if the master does not operate, the slave axis will not operate. If the master operates, the slave will travel according to the E-cam table.</li> <li>● For one cycle of the chart, the slave axis operates a cycle.</li> <li>● E-cam axis can operate in forward / reverse direction.</li> <li>● If the E-cam position is between two points of the E-cam table, the position of the slave axis will be interpolated with cubic curve function. The adjacent curve remains quadratic differential at the point in order to smooth torque. The point amount of the table will not influence the smoothing operation of E-cam.</li> </ul>

■ Gear # 2, the description is as follows:

Function	<ul style="list-style-type: none"> <li>● Set the relation between slave axis and pulse command</li> <li>● The slave axis operates a cycle, but the pulse command might not operate a cycle.</li> </ul>
Description	<ul style="list-style-type: none"> <li>● The slave axis is a virtual axis and the unit of slave position is PUU.</li> <li>● The pulse command is the encoder unit (pulse). The resolution is 1280000 pulse/rev.</li> <li>● For one cycle of the chart, the slave axis operates a cycle.</li> </ul>

Setting Method P1-44: numerator P1-45: denominator	<ul style="list-style-type: none"> <li>● If the pulse number of slave axis is L, the motor axis operates R cycle. Then, the setting of gear ratio is <math>P1-44/P1-45 = 1280000 \times R / L</math></li> <li>● The gear ratio of PT and PR is the same.</li> </ul>
--	---

■ Digital Output of E-cam, the description is as follows:

DO Name and Number	<ul style="list-style-type: none"> <li>● DO.CAM_AREA (DO no.= 0x18)</li> </ul>
Function	<ul style="list-style-type: none"> <li>● If DO.CAM_AREA is ON, it means the position of E-cam axis is in the setting range.</li> </ul>
When the E-cam is engaging	<ul style="list-style-type: none"> <li>● Set the angle range of DO ON by P5-90 and P5-91.</li> <li>● Please refer to table 1 and 2 below</li> </ul>
When the E-cam is disengaging	<ul style="list-style-type: none"> <li>● DO.CAM_AREA is OFF.</li> </ul>

Table 1 P5-90 <= P5-91:

E-Cam angle	0°	~	P5-90	~	P5-91	~	360°
DO:CAM_AREA	OFF	OFF	ON	ON	ON	OFF	OFF

Table 2 P5-90 > P5-91:

E-Cam angle	0°	~	P5-91	~	P5-90	~	360°
DO:CAM_AREA	ON	ON	OFF	OFF	OFF	ON	ON

### 7.11.1 Function Description of CAPTURE (Data Capture)

The concept of CAPTURE is to capture the position of motion axis instantaneously by using the external trigger signal DI7. Then save it in data array so as to be used for motion control afterwards. Since CAPTURE is finished by hardware, there is no problem of software delay. It also can accurately capture the high-speed motion axis. The CAPTURE features provided by this servo drive is as follows.

CAPTURE Features	
Pulse Source	<ul style="list-style-type: none"> <li>● Main encoder of the motor</li> <li>● Auxiliary encoder (linear scale)</li> <li>● Pulse command</li> </ul> The selected axis will be displayed in P5-37, the default value can be written in before capture. Note: When the source of COMPARE is CAP axis, the CAP source cannot be changed.
Trigger signal	<ul style="list-style-type: none"> <li>● Triggered by DI7, the response time is 5 usec.</li> </ul> Note: DI7 directly connects to CAPTURE hardware. Thus, regardless the setting value of P2-16 (DI Code), CAPTURE can work. When using CAPTURE, in order to avoid DI error, system will force to disable DI function, which means the setting will be P2-16 = 0x0100 automatically. Since the value is not written into EEPROM, P2-16 will return to the default value after re-power on.

CAPTURE Features	
Trigger method	<ul style="list-style-type: none"> <li>● Edge trigger can select contact A/B</li> <li>● It is capable to continuously capture more than one point.</li> <li>● It can set the trigger interval. (The interval between this trigger and the next one.)</li> </ul>
Data storage position	<ul style="list-style-type: none"> <li>● Data array. The start address is set by P5-36.</li> </ul>
Capture number	<ul style="list-style-type: none"> <li>● It is set via P5-38 and will not exceed the limit of data array.</li> </ul>
Capture format	<ul style="list-style-type: none"> <li>● 32-bit (It has positive and negative.)</li> </ul>
Auxiliary selection	<ul style="list-style-type: none"> <li>● After capturing the first data, the CAP axis coordinate system will be set to the value the same as P5-76.</li> <li>● After capturing the first data, the COMPARE function is enabled automatically.</li> <li>● After capturing all points, PR procedure # 50 is triggered automatically.</li> </ul>
DO.CAP_OK	<ul style="list-style-type: none"> <li>● The default value is OFF.</li> <li>● After capturing the last point, this DO is ON.</li> <li>● Set P5-39.X0 to 1 so as to activate CAPTURE function and this DO is OFF.</li> </ul>
Note	<ul style="list-style-type: none"> <li>● If P5-38=0, set the value of P5-39 X, Bit0 to 1 will disable the CAPTURE function. Clear the setting value of P5-39 X, Bit0 to 0 and set DO.CAP_OK to OFF.</li> <li>● Since the capture axis is 32-bit wide, the accumulation will cause overflow. Please avoid this.</li> </ul>

The CAP data is saved in data array and the first CAP data locates in P5-36. The CAP number has no limit, thus it can be set via P5-38. The last CAP data is saved in P5-36 + P5-38 - 1. Set the value of P5-39 X, Bit0 to 1 so as to activate CAP function. Every time when DI7 is triggered, one data will be captured and saved in data array. Then, the value of P5-38 will decrease one automatically until the CAP number reaches the setting value (P5-38 = 0). The CAP procedure is completed, the setting value of P5-39 X, Bit0 will be cleared to 0 and DO.CAP\_OK is ON.

When capturing the first data, the position of CAP axis can be reset. The first CAP value will be the value set by P5-76. And the value of the second CAP data will be the incremental value from the first data. This method is called Relative Capture. If not selecting the first data reset, it is called Absolute Capture.

When capturing the first data, it automatically activates COMPARE function, which means the COMPARE function, is activated via DI5.



The diagram of CAP:

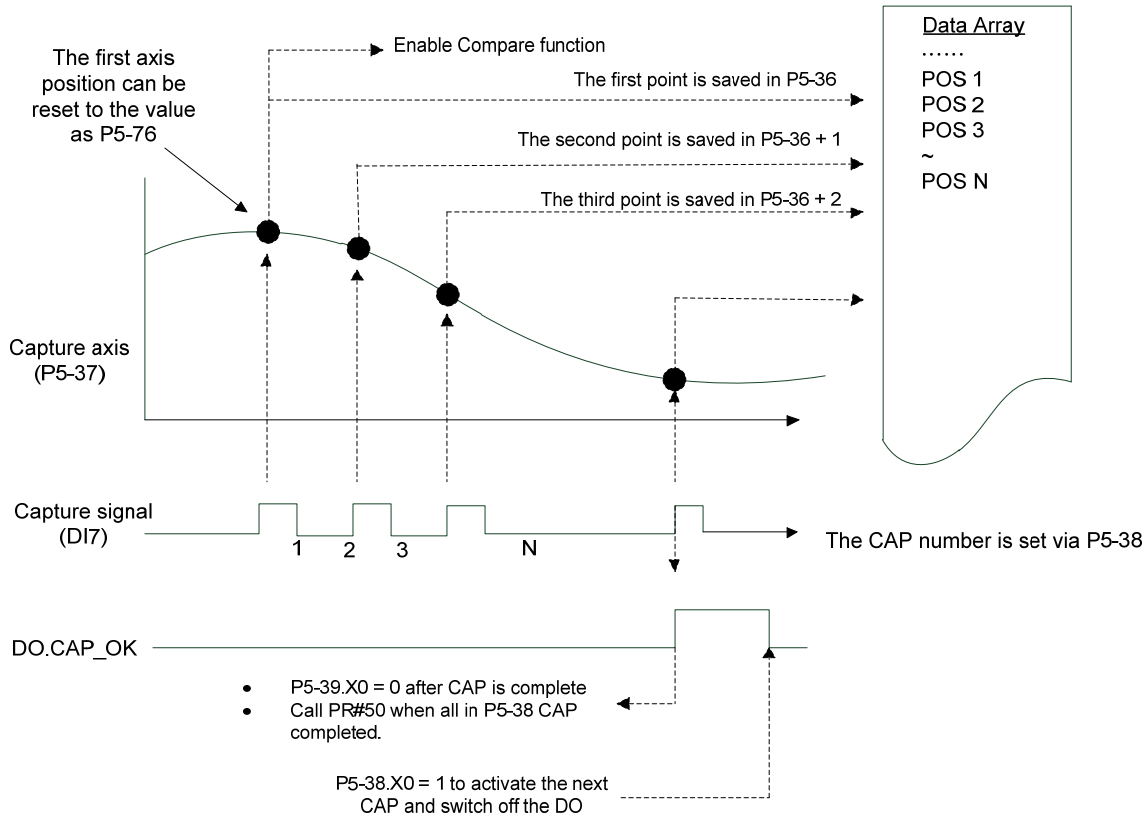

### 7.11.2 Function Description of COMPARE (Data Compare)

The concept of COMPARE is to compare the instant position of motion axis with the value which is saved in data array. Then output DO3 after the COMPARE condition is established for motion control. Since COMPARE is finished by hardware, there is no problem of software delay. It also can accurately compare the high-speed motion axis. The COMPARE features provided by this servo drive is as follows.

COMPARE Features	
Pulse Source	<ul style="list-style-type: none"> <li>● Main Encoder of the Motor</li> <li>● Auxiliary Encoder (linear scale)</li> <li>● Pulse Command</li> <li>● CAP Axis (set by CAPTURE). When selecting this axis, CAP source cannot be changed.</li> </ul> <p>The selected axis is displayed in P5-57. Before compare, the default value can be written in.</p>
Output Signal	<ul style="list-style-type: none"> <li>● Output by DO4 and the response time is 5 usec.</li> </ul> <p>Note: DO3 directly connects to COMPARE hardware, thus, regardless the setting value of P2-20 (DO Code), the function can work. When using COMPARE, in order to avoid DO error, the system will force to disable DO function, which means the setting will be P2-21 = 0x0100 automatically. Since the value is not written into EEPROM, P2-21 will return to the default value after re-power on.</p>
Output Method	<ul style="list-style-type: none"> <li>● Pulse output can select contact A/B.</li> <li>● It is capable to continuously output more than one point.</li> <li>● It can set the pulse output time.</li> </ul>

Data Storage Position	<ul style="list-style-type: none"> <li>● Data array. The start address is set by P5-56.</li> </ul>
Compare Number	<ul style="list-style-type: none"> <li>● It is set via P5-58 and will not exceed the limit of data array.</li> </ul>
Compare Format	<ul style="list-style-type: none"> <li>● 32-bit (It has positive and negative.)</li> </ul>
Compare Condition	<ul style="list-style-type: none"> <li>● It will be triggered when the source of compare axis pass through the compare value.</li> </ul>
Auxiliary Selection	<ul style="list-style-type: none"> <li>● Cycle mode: When comparing to the last point, it automatically returns to the first point and starts to compare.</li> <li>● When the last compare is completed, the CAPTURE function is activated automatically.</li> </ul>
Note	<ul style="list-style-type: none"> <li>● If P5-58 is set to 0, set the value of P5-59 X, Bit0 to 1 will be unable to compare. Set the value of P5-59 X, Bit0 to 0.</li> <li>● Since the capture axis is 32-bit wide, the accumulation will cause overflow. Please avoid this.</li> </ul>

The value of COMPARE is saved in data array and the first compare data locates in P5-56. The CMP number has no limit, thus it can be set via P5-58. The last CMP data is saved in P5-56 + P5-58 - 1. Set the value of P5-59 X, Bit0 to 1 so as to activate CMP function and start to compare the first data of data array. Every time when a position saved in data array is compared, the compare DO will be outputted. Then, the value of P5-58 will decrease one automatically and compare the next value until the CMP number reaches the setting value (P5-58 = 0). When the CMP procedure is completed, the setting value of P5-59 X, Bit0 will be cleared to 0.

When comparing to the last point, it can select if it returns to the first data for comparing. This is called cycle mode. Or it can activate CAPTURE function and wait DI7 for triggering CAP/CMP procedure.

The diagram of COMPARE:

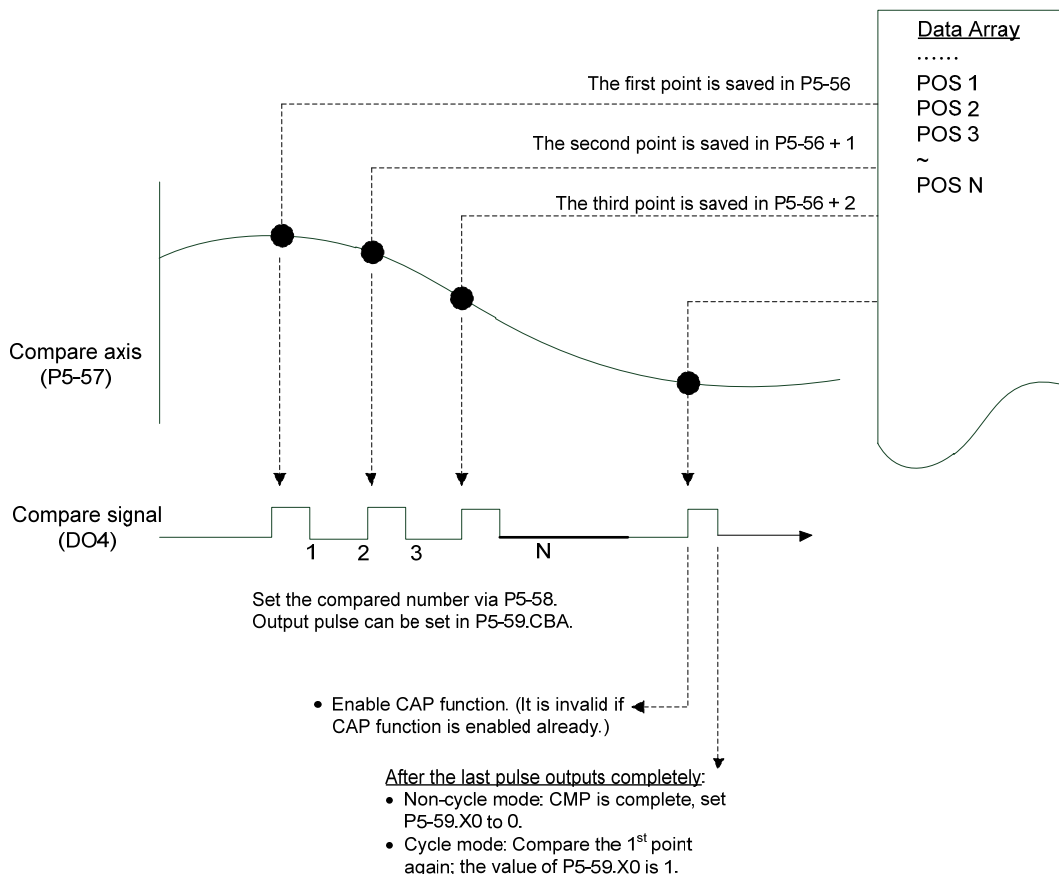

(This page is intentionally left blank.)

# Chapter 8 Parameters

---

## 8.1 Parameter Definition

Parameters are divided into eight groups which are shown as follows. The first character after the start code P is the group character and the second character is the parameter character.

As for the communication address, it is the combination of group number along with two digit number in hexadecimal. The definition of parameter groups is as the followings:

Group 0: Monitor parameters	(example: P0-xx)
Group 1: Basic parameters	(example: P1-xx)
Group 2: Extension parameters	(example: P2-xx)
Group 3: Communication parameters	(example: P3-xx)
Group 4: Diagnosis parameters	(example: P4-xx)
Group 5: Motion control parameters	(example: P5-xx)
Group 6: PR parameters	(example: P6-xx)
Group 7: PR parameters	(example: P7-xx)

### Control Mode Description:

PT	:	Position control mode (Input the position command via the terminal block)
PR	:	Position control mode (The internal register issues the position command)
S	:	Speed control mode
T	:	Torque control mode
DMC	:	DMCNET control mode

### Special Symbol Description

- (★) Read-only register, can only read the status. For example: parameter P0-00, P0-10 and P4-00, etc.
- (▲) Setting is unable when Servo On, e.g. parameter P1-00, P1-46 and P2-33, etc.
- (●) Not effective until re-power on or off the servo drive, e.g. parameter P1-01 and P3-00.
- (■) Parameters of no data retained setting, e.g. parameter P2-31 and P3-06.

## 8.2 List of Parameters

Monitor and General Output Parameter									
Parameter	Abbr.	Function	Default	Unit	Control Mode				Related Section
					PT	PR	S	T	
P0-00★	VER	Firmware Version	Factory Setting	N/A	O	O	O	O	-
P0-01■	ALE	Alarm Code Display of Drive (Seven-segment Display)	N/A	N/A	O	O	O	O	11.1 11.2 11.3
P0-02	STS	Drive Status	00	N/A	O	O	O	O	7.2
P0-03	MON	Analog Output Monitor	01	N/A	O	O	O	O	4.3.5
P0-08★	TSON	Servo On Time	0	Hour					-
P0-09★	CM1	Status Monitor Register 1	N/A	N/A	O	O	O	O	4.3.5
P0-10★	CM2	Status Monitor Register 2	N/A	N/A	O	O	O	O	4.3.5
P0-11★	CM3	Status Monitor Register 3	N/A	N/A	O	O	O	O	4.3.5
P0-12★	CM4	Status Monitor Register 4	N/A	N/A	O	O	O	O	4.3.5
P0-13★	CM5	Status Monitor Register 5	N/A	N/A	O	O	O	O	4.3.5
P0-17	CM1A	Status Monitor Register 1 Selection	0	N/A					-
P0-18	CM2A	Status Monitor Register 2 Selection	0	N/A					-
P0-19	CM3A	Status Monitor Register 3 Selection	0	N/A					-
P0-20	CM4A	Status Monitor Register 4 Selection	0	N/A					-
P0-21	CM5A	Status Monitor Register 5 Selection	0	N/A					-
P0-25	MAP1	Mapping Parameter # 1	No need to initialize	N/A	O	O	O	O	4.3.5
P0-26	MAP2	Mapping Parameter # 2	No need to initialize	N/A	O	O	O	O	4.3.5
P0-27	MAP3	Mapping Parameter # 3	No need to initialize	N/A	O	O	O	O	4.3.5
P0-28	MAP4	Mapping Parameter # 4	No need to initialize	N/A	O	O	O	O	4.3.5
P0-29	MAP5	Mapping Parameter # 5	No need to initialize	N/A	O	O	O	O	4.3.5
P0-30	MAP6	Mapping Parameter # 6	No need to initialize	N/A	O	O	O	O	4.3.5
P0-31	MAP7	Mapping Parameter # 7	No need to initialize	N/A	O	O	O	O	4.3.5
P0-32	MAP8	Mapping Parameter # 8	No need to initialize	N/A	O	O	O	O	4.3.5

Monitor and General Output Parameter									
Parameter	Abbr.	Function	Default	Unit	Control Mode				Related Section
					PT	PR	S	T	
P0-35	MAP1A	Target Setting of Mapping Parameter P0-25	0x0	N/A	O	O	O	O	4.3.5
P0-36	MAP2A	Target Setting of Mapping Parameter P0-26	0x0	N/A	O	O	O	O	4.3.5
P0-37	MAP3A	Target Setting of Mapping Parameter P0-27	0x0	N/A	O	O	O	O	4.3.5
P0-38	MAP4A	Target Setting of Mapping Parameter P0-28	0x0	N/A	O	O	O	O	4.3.5
P0-39	MAP5A	Target Setting of Mapping Parameter P0-29	0x0	N/A	O	O	O	O	4.3.5
P0-40	MAP6A	Target Setting of Mapping Parameter P0-30	0x0	N/A	O	O	O	O	4.3.5
P0-41	MAP7A	Target Setting of Mapping Parameter P0-31	0x0	N/A	O	O	O	O	4.3.5
P0-42	MAP8A	Target Setting of Mapping Parameter P0-32	0x0	N/A	O	O	O	O	4.3.5
P0-46★	SVSTS	Servo Digital Output Status Display	0	N/A	O	O	O	O	-
P1-04	MON1	MON1 Analog Monitor Output Proportion	100	%(full scale)	O	O	O	O	6.4.4
P1-05	MON2	MON2 Analog Monitor Output Proportion	100	%(full scale)	O	O	O	O	6.4.4

- (★) Read-only register, can only read the status. For example: parameter P0-00, P0-10 and P4-00, etc.
- (▲) Setting is invalid when Servo On, e.g. parameter P1-00, P1-46 and P2-33, etc.
- (●) Not effective until re-power on or off the servo drive, e.g. parameter P1-01 and P3-00.
- (■) Parameters of no data retained setting, e.g. parameter P2-31 and P3-06.

Filter and Resonance Suppression Parameter									
Parameter	Abbr.	Function	Default	Unit	Control Mode				Related Section
					PT	PR	S	T	
P1-06	SFLT	Analog Speed Command (Low-pass Filter)	0	ms			O		6.3.3
P1-07	TFLT	Analog Torque Command (Low-pass Filter)	0	ms				O	6.4.3
P1-08	PFLT	Smooth Constant of Position Command (Low-pass Filter)	0	10 ms	O	O			6.2.6
P1-25	VSF1	Low-frequency Vibration Suppression (1)	100.0	0.1Hz	O	O			6.2.9
P1-26	VSG1	Low-frequency Vibration Suppression Gain (1)	0	N/A	O	O			6.2.9
P1-27	VSF2	Low-frequency Vibration Suppression (2)	100.0	0.1Hz	O	O			6.2.9
P1-28	VSG2	Low-frequency Vibration Suppression Gain (2)	0	N/A	O	O			6.2.9
P1-29	AVSM	Auto Low-frequency Vibration Suppression Setting	0	N/A	O	O			6.2.9
P1-30	VCL	Low-frequency Vibration Detection	500	pulse	O	O			6.2.9
P1-34	TACC	Acceleration Constant of S-Curve	200	ms		O	O		6.3.3
P1-35	TDEC	Deceleration Constant of S-Curve	200	ms		O	O		6.3.3
P1-36	TSL	Acceleration / Deceleration Constant of S-Curve	0	ms		O	O		6.3.3
P1-59	MFLT	Analog Speed Command	0	0.1ms			O		-
P1-62	FRCL	Friction Compensation	0	%	O	O	O	O	-
P1-63	FRCT	Friction Compensation	0	ms	O	O	O	O	-
P1-68	PFLT2	Position Command Moving Filter	0	ms	O	O			-
P1-75	FELP	Low-pass Filter Time Constant of Full-closed Loop control	100	ms	O	O			-
P2-23	NCF1	Resonance suppression (Notch filter) (1)	1000	Hz	O	O	O	O	6.3.7
P2-24	DPH1	Resonance Suppression (Notch filter) Attenuation Rate (1)	0	dB	O	O	O	O	6.3.7
P2-43	NCF2	Resonance suppression (Notch filter) (2)	1000	Hz	O	O	O	O	6.3.7
P2-44	DPH2	Resonance Suppression (Notch filter) Attenuation Rate (2)	0	dB	O	O	O	O	6.3.7
P2-45	NCF3	Resonance suppression (Notch filter) (3)	1000	Hz	O	O	O	O	6.3.7

P2-46	DPH3	Resonance Suppression (Notch filter) Attenuation Rate (3)	0	dB	O	O	O	O	6.3.7
P2-47	ANCF	Auto Resonance Suppression Mode Setting	1	N/A	O	O	O	O	-
P2-48	ANCL	Resonance Suppression Detection Level	100	N/A	O	O	O	O	-
P2-25	NLP	Low-pass Filter of Resonance Suppression	2 or 5	0.1ms	O	O	O	O	6.3.7
P2-33▲	INF	Semi-auto Inertia Adjustment	0	N/A	O	O	O	O	6.3.6
P2-49	SJIT	Speed Detection Filter	0	-	O	O	O	O	-

(★) Read-only register, can only read the status. For example: parameter P0-00, P0-10 and P4-00, etc.

(▲) Setting is unable when Servo On, e.g. parameter P1-00, P1-46 and P2-33, etc.

(●) Not effective until re-power on or off the servo drive, e.g. parameter P1-01 and P3-00.

(■) Parameters of no data retained setting, e.g. parameter P2-31 and P3-06.

### Gain and Switch Parameter

Parameter	Abbr.	Function	Default	Unit	Control Mode				Related Section
					PT	PR	S	T	
P2-00	KPP	Position Loop Gain	35	rad/s	O	O			6.2.8
P2-01	PPR	Switching Rate of Position Loop Gain	100	%	O	O			6.2.8
P2-02	PFG	Position Feed Forward Gain	50	%	O	O			6.2.8
P2-03	PFF	Smooth Constant of Position Feed Forward Gain	5	ms	O	O			-
P2-04	KVP	Speed Loop Gain	500	rad/s	O	O	O	O	6.3.6
P2-05	SPR	Switching Rate of Speed Loop Gain	100	%	O	O	O	O	-
P2-06	KVI	Speed Integral Compensation	100	rad/s	O	O	O	O	6.3.6
P2-07	KVF	Speed Feed Forward Gain	0	%	O	O	O	O	6.3.6
P2-26	DST	Anti-interference Gain	0	0.001	O	O	O	O	-
P2-27	GCC	Gain Switching and Switching Selection	0	N/A	O	O	O	O	-
P2-28	GUT	Gain Switching Time Constant	10	10 ms	O	O	O	O	-
P2-29	GPE	Gain Switching	1280000	pulse Kpps r/min (rotary motor) $10^{-3}$ m/s (linear motor)	O	O	O	O	-
P2-31■	AUT1	Speed Loop Frequency Response Setting in Auto and Semi-auto Mode	80	Hz	O	O	O	O	5.6
									6.3.6



P2-32▲	AUT2	Tuning Mode Selection	0	N/A	○	○	○	○	5.6
									6.3.6

- (★) Read-only register, can only read the status. For example: parameter P0-00, P0-10 and P4-00, etc.
- (▲) Setting is unable when Servo On, e.g. parameter P1-00, P1-46 and P2-33, etc.
- (●) Not effective until re-power on or off the servo drive, e.g. parameter P1-01 and P3-00.
- (■) Parameters of no data retained setting, e.g. parameter P2-31 and P3-06.

Position Control Parameter									
Parameter	Abbr.	Function	Default	Unit	Control Mode				Related Section
					PT	PR	S	T	
P1-01●	CTL	Input Setting of Control Mode and Control Command	0	pulse r/min N-M	○	○	○	○	6.1
P1-02▲	PSTL	Speed and Torque Limit Setting	0	N/A	○	○	○	○	6.6
P1-12 ~ P1-14	TQ1 ~ 3	Internal Torque Limit 1 ~ 3	100	%	○	○	○	○	6.4.1
P1-46▲	GR3	Pulse Number of Encoder Output	2500	pulse	○	○	○	○	-
P1-55	MSPD	Maximum Speed Setting	rated	r/min	○	○	○	○	-
P1-72	FRES	Resolution of Linear Scale for full-closed loop control	5000	Pulse/ rev	○	○			-
P1-73	FERR	Error Protection Range for Full-closed Loop Control	30000	pulse	○	○			-
P1-74	FCON	Full-closed Loop Control of Linear Scale	000h	-	○	○			-
P2-50	DCLR	Pulse Clear Mode	0	N/A	○	○			-
External Pulse Command (PT mode)									
P1-00▲	PTT	External Pulse Input Type	0x2	N/A	○				6.2.1
P1-44▲	GR1	Gear Ratio (Numerator) (N1)	1	pulse	○	○			6.2.5
P1-45▲	GR2	Gear Ratio (Denominator) (M)	1	pulse	○	○			6.2.5
P2-60	GR4	Gear Ratio (Numerator) (N2)	1	pulse	○				-
P2-61	GR5	Gear Ratio (Numerator) (N3)	1	pulse	○				-
P2-62	GR6	Gear Ratio (Numerator) (N4)	1	pulse	○				-
Register Control Command (PR mode)									
P6-02 ~ P7-27	PO1 ~ PO63	Internal Position Command 1 ~ 63	0	N/A		○			7.10
P5-60 ~ P5-75	POV1 ~ POV15	Target Speed Setting#0 ~ 15	20 ~ 3000	0.1r/min		○			7.10
P5-03	PDEC	Deceleration Time of Auto Protection	0XF00FF FFF	N/A	○	○	○	○	-

Position Control Parameter									
Parameter	Abbr.	Function	Default	Unit	Control Mode				Related Section
					PT	PR	S	T	
P5-04	HMOV	Homing Mode	0	N/A	O	O			-
P5-05	HSPD1	1 <sup>st</sup> Speed Setting of High Speed Homing	100	0.1r/min	O	O	O	O	-
P5-06	HSPD2	2 <sup>nd</sup> Speed Setting of Low Speed Homing	20	0.1r/min	O	O	O	O	-
P5-07	PRCM	Trigger Position Command (PR mode only)	0	N/A		O			-
P5-20 ~ P5-35	AC0 ~ AC15	Acceleration/Deceleration Time	200 ~ 30	ms		O			7.10
P5-40 ~ P5-55	DLY0 ~ DLY15	Delay Time after Position Completed	0 ~ 5500	ms		O			7.10
P5-98	EVON	Position Command of Event Rising-edge Trigger	0	N/A		O			-
P5-99	EVOF	Position Command of Event Falling-edge Trigger	0	N/A		O			-
P5-15	PMEM	PATH#1 ~ PATH#2 No Data Retained Setting	0x0	N/A	O	O	O	O	-
P5-16	AXEN	Axis Position - Motor Encoder	N/A	N/A	O	O	O	O	7.3
P5-17	AXAU	Axis Position - Auxiliary Encoder	N/A	N/A	O	O	O	O	7.3
P5-18	AXPC	Axis Position - Pulse Command	N/A	N/A	O	O	O	O	7.3
P5-08	SWLP	Forward Software Limit	+2 <sup>31</sup>	PUU		O			-
P5-09	SWLN	Reverse Software Limit	-2 <sup>31</sup>	PUU		O			-

- (★) Read-only register, can only read the status. For example: parameter P0-00, P0-10 and P4-00, etc.
- (▲) Setting is unable when Servo On, e.g. parameter P1-00, P1-46 and P2-33, etc.
- (●) Not effective until re-power on or off the servo drive, e.g. parameter P1-01 and P3-00.
- (■) Parameters of no data retained setting, e.g. parameter P2-31 and P3-06.

Speed Control Parameter									
Parameter	Abbr.	Function	Default	Unit	Control Mode				Related Section
					PT	PR	S	T	
P1-01●	CTL	Input Setting of Control Mode and Control Command	0	pulse r/min N-M	O	O	O	O	6.1
P1-02▲	PSTL	Speed and Torque Limit Setting	0	N/A	O	O	O	O	6.6
P1-46▲	GR3	Output Pulse Counts Per One Motor Revolution	1	pulse	O	O	O	O	-
P1-55	MSPD	Maximum Speed Limit	rated	r/min	O	O	O	O	-

P1-09 ~ P1-11	SP1 ~ 3	Internal Speed Command 1 ~ 3	1000 ~ 3000	0.1 r/min			O	O	6.3.1
P1-12 ~ P1-14	TQ1 ~ 3	Internal Torque Limit 1 ~ 3	100	%	O	O	O	O	6.6.2
P1-40▲	VCM	Maximum Speed of Analog Speed Command	rated	r/min			O	O	6.3.4
P1-41▲	TCM	Maximum Output of Analog Torque Speed	100	%	O	O	O	O	-
P1-76	AMSPD	Maximum Rotation Setting of Encoder Setting (OA, OB)	5500	r/min	O	O	O	O	-

(★) Read-only register, can only read the status. For example: parameter P0-00, P0-10 and P4-00, etc.

(▲) Setting is unable when Servo On, e.g. parameter P1-00, P1-46 and P2-33, etc.

(●) Not effective until re-power on or off the servo drive, e.g. parameter P1-01 and P3-00.

(■) Parameters of no data retained setting, e.g. parameter P2-31 and P3-06.

Torque Control Parameter									
Parameter	Abbr.	Function	Default	Unit	Control Mode				Related Section
					PT	PR	S	T	
P1-01●	CTL	Input Setting of Control Mode and Control Command	0	pulse r/min N-M	O	O	O	O	6.1
P1-02▲	PSTL	Speed and Torque Limit Setting	0	N/A	O	O	O	O	6.6
P1-46▲	GR3	Output Pulse Counts Per One Motor Revolution	1	pulse	O	O	O	O	-
P1-55	MSPD	Maximum Speed Limit	rated	r/min	O	O	O	O	-
P1-09 ~ P1-11	SP1~3	Internal Speed Limit 1~3	100 ~ 300	0.1 r/min			O	O	6.6.1
P1-12 ~ P1-14	TQ1~3	Internal Torque Command 1~3	100	%	O	O	O	O	6.4.1
P1-40▲	VCM	Maximum Speed of Analog Speed Command	rated	r/min			O	O	-
P1-41▲	TCM	Maximum Output of Analog Torque Limit	100	%	O	O	O	O	6.4.4

(★) Read-only register, can only read the status. For example: parameter P0-00, P0-10 and P4-00, etc.

(▲) Setting is unable when Servo On, e.g. parameter P1-00, P1-46 and P2-33, etc.

(●) Not effective until re-power on or off the servo drive, e.g. parameter P1-01 and P3-00.

(■) Parameters of no data retained setting, e.g. parameter P2-31 and P3-06.

Planning of Digital Input / Output Pin and Output Setting Parameter									
Parameter	Abbr.	Function	Default	Unit	Control Mode				Related Section
					PT	PR	S	T	
P2-09	DRT	DI Debouncing Time	2	ms	0	0	0	0	-
P2-10	DI1	DI1 Functional Planning	101	N/A	0	0	0	0	Table 8.1
P2-11	DI2	DI2 Functional Planning	104	N/A	0	0	0	0	Table 8.1
P2-12	DI3	DI3 Functional Planning	116	N/A	0	0	0	0	Table 8.1
P2-13	DI4	DI4 Functional Planning	117	N/A	0	0	0	0	Table 8.1
P2-14	DI5	DI5 Functional Planning	102	N/A	0	0	0	0	Table 8.1
P2-15	DI6	DI6 Functional Planning	22	N/A	0	0	0	0	Table 8.1
P2-16	DI7	DI7 Functional Planning	23	N/A	0	0	0	0	Table 8.1
P2-17	DI8	DI8 Functional Planning	21	N/A	0	0	0	0	Table 8.1
P2-36	EDI9	DI9 Functional Planning	0	N/A	0	0	0	0	Table 8.1
P2-37	EDI10	DI10 Functional Planning	0	N/A	0	0	0	0	Table 8.1
P2-38	EDI11	DI11 Functional Planning	0	N/A	0	0	0	0	Table 8.1
P2-39	EDI12	DI12 Functional Planning	0	N/A	0	0	0	0	Table 8.1
P2-40	EDI13	DI13 Functional Planning	0	N/A	0	0	0	0	Table 8.1
P2-41	EDI14	DI14 Functional Planning	0	N/A	0	0	0	0	Table 8.1
P2-18	DO1	DO1 Functional Planning	101	N/A	0	0	0	0	Table 8.2
P2-19	DO2	DO2 Functional Planning	103	N/A	0	0	0	0	Table 8.2
P2-20	DO3	DO3 Functional Planning	109	N/A	0	0	0	0	Table 8.2
P2-21	DO4	DO4 Functional Planning	105	N/A	0	0	0	0	Table 8.2
P2-22	DO5	DO5 Functional Planning	7	N/A	0	0	0	0	Table 8.2
P1-38	ZSPD	Zero Speed Range Setting	100	0.1 r/min	0	0	0	0	Table 8.2
P1-39	SSPD	Target Motor Detection Level	3000	r/min	0	0	0	0	Table 8.2
P1-42	MBT1	Enable Delay Time of Brake	0	ms	0	0	0	0	6.5.5

P1-43	MBT2	Disable Delay Time of Brake	0	ms	O	O	O	O	6.5.5
P1-47	SCPD	Speed Reached (DO : SP_OK) Range	10	r/min			O		Table 8.2
P1-54	PER	Position Completed Range	12800	pulse	O	O			Table 8.2
P1-56	OVW	Output Overload Warning Level	120	%	O	O	O	O	Table 8.2

- (★) Read-only register, can only read the status. For example: parameter P0-00, P0-10 and P4-00, etc.
- (▲) Setting is unable when Servo On, e.g. parameter P1-00, P1-46 and P2-33, etc.
- (●) Not effective until re-power on or off the servo drive, e.g. parameter P1-01 and P3-00.
- (■) Parameters of no data retained setting, e.g. parameter P2-31 and P3-06.

Communication Parameter									
Parameter	Abbr.	Function	Default	Unit	Control Mode				Related Section
					PT	PR	S	T	
P3-00●	ADR	Address Setting	0x01	N/A	O	O	O	O	9.2
P3-01	BRT	Transmission Speed	0x3203	bps	O	O	O	O	9.2
P3-02	PTL	Communication Protocol	6	N/A	O	O	O	O	9.2
P3-03	FLT	Communication Error Disposal	0	N/A	O	O	O	O	9.2
P3-04	CWD	Communication Timeout	0	sec	O	O	O	O	9.2
P3-05	CMM	Communication Mechanism	0	N/A	O	O	O	O	9.2
P3-06■	SDI	Control Switch of Digital Input (DI)	0	N/A	O	O	O	O	9.2
P3-07	CDT	Communication Response Delay Time	0	1ms	O	O	O	O	9.2
P3-08	MNS	Monitor Mode	0000	N/A	O	O	O	O	9.2
P3-09	SYC	CANopen Synchronize Setting	0x57A1	N/A					
		DMCNET Synchornize Setting	0x3511						
P3-10	CANEN	CANopen Protocol Setting	0x0000	N/A					
		DMCNET Protocol Setting	1						
P3-11	CANOP	CANopen Selection	0	N/A					
		DMCNET Selection	0						
P3-12	QSTPO	CANopen Support Setting	0	N/A					
		DMCNET Support Setting	0						

- (★) Read-only register, can only read the status. For example: parameter P0-00, P0-10 and P4-00, etc.
- (▲) Setting is unable when Servo On, e.g. parameter P1-00, P1-46 and P2-33, etc.
- (●) Not effective until re-power on or off the servo drive, e.g. parameter P1-01 and P3-00.
- (■) Parameters of no data retained setting, e.g. parameter P2-31 and P3-06.

Diagnosis Parameter									
Parameter	Abbr.	Function	Default	Unit	Control Mode				Related Section
					PT	PR	S	T	
P4-00★	ASH1	Fault Record (N)	0	N/A	O	O	O	O	4.4.1
P4-01★	ASH2	Fault Record (N-1)	0	N/A	O	O	O	O	4.4.1
P4-02★	ASH3	Fault Record (N-2)	0	N/A	O	O	O	O	4.4.1
P4-03★	ASH4	Fault Record (N-3)	0	N/A	O	O	O	O	4.4.1
P4-04★	ASH5	Fault Record (N-4)	0	N/A	O	O	O	O	4.4.1
P4-05	JOG	Servo Motor Jog Control	20	r/min	O	O	O	O	4.4.2
P4-06▲■	FOT	Digital Output Register (Readable and Writable)	0	N/A	O	O	O	O	4.4.4
P4-07	ITST	Multi-function of Digital Input	0	N/A	O	O	O	O	4.4.5 9.2
P4-08★	PKEY	Input Status of the Drive Keypad	N/A	N/A	O	O	O	O	-
P4-09★	MOT	Digital Output Status	N/A	N/A	O	O	O	O	4.4.6
P4-10▲	CEN	Adjustment Selection	0	N/A	O	O	O	O	-
P4-11	SOF1	Analog Speed Input Offset Adjustment 1	Factory Setting	N/A	O	O	O	O	-
P4-12	SOF2	Analog Speed Input Offset Adjustment 2	Factory Setting	N/A	O	O	O	O	-
P4-13	TOF1	Analog Torque Input Offset Adjustment 1	Factory Setting	N/A	O	O	O	O	-
P4-14	TOF2	Analog Torque Input Offset Adjustment 2	Factory Setting	N/A	O	O	O	O	-
P4-15	COF1	Current Detector (V1 Phase) Offset Adjustment	Factory Setting	N/A	O	O	O	O	-
P4-16	COF2	Current Detector (V2 Phase) Offset Adjustment	Factory Setting	N/A	O	O	O	O	-
P4-17	COF3	Current Detector (W1 Phase) Offset Adjustment	Factory Setting	N/A	O	O	O	O	-
P4-18	COF4	Current Detector (W2 Phase) Offset Adjustment	Factory Setting	N/A	O	O	O	O	-
P4-19	TIGB	IGBT NTC Adjustment Detection Level	Factory Setting	N/A	O	O	O	O	-
P4-20	DOF1	Offset Adjustment Value of Analog Monitor Output (Ch1)	0	mV	O	O	O	O	6.4.4
P4-21	DOF2	Offset Adjustment Value of Analog Monitor Output (Ch2)	0	mV	O	O	O	O	6.4.4
P4-22	SAO	Analog Speed Input OFFSET	0	mV			O		-
P4-23	TAO	Analog Torque Input OFFSET	0	mV				O	-

(★) Read-only register, can only read the status. For example: parameter P0-00, P0-10 and P4-00, etc.

(▲) Setting is unable when Servo On, e.g. parameter P1-00, P1-46 and P2-33, etc.

- (●) Not effective until re-power on or off the servo drive, e.g. parameter P1-01 and P3-00.
- (■) Parameters of no data retained setting, e.g. parameter P2-31 and P3-06.

## 8.3 Parameter Description

### P0-xx Monitor Parameters

P0-00★	VER	Firmware Version	Address: 0000H 0001H
	Operational Interface :	Panel / Software      Communication	Related Section: -
	Default :	Factory Setting	
	Control Mode :	ALL	
	Unit :	-	
	Range :	-	
	Data Size :	16-bit	
	Format :	Decimal	
	Settings : This parameter shows the firmware version of the servo drive.		

P0-01■	ALE	Alarm Code Display of Drive (Seven-segment Display)	Address: 0002H 0003H
	Operational Interface :	Panel / Software      Communication	Related Section: 11.1, 11.2, 11.3
	Default :	-	
	Control Mode :	ALL	
	Unit :	-	
	Range :	0x0000~0xFFFF: It only can be set to 0 to clear the alarm (Same as DI.ARST).	
	Data Size :	16-bit	
	Format :	BCD	
	Settings : Hexadecimal format: displays the alarm code		



## Alarm of Servo Drive

001 : Over current

002 : Over voltage

003 : Under voltage (In default setting, the alarm occurs only when the voltage is not enough in Servo ON status; In Servo ON status, when it applies to power R, S, T, the alarm still will not be cleared. Please refer to P2-66.)

004 : Motor combination error (The drive corresponds to the wrong motor)

005 : Regeneration error

006 : Over load

007 : Over speed

008 : Abnormal pulse command

009 : Excessive deviation of position command

010 : Reserved

011 : Encoder error (The servo drive cannot connect to the encoder because of disconnection or abnormal wiring)

012 : Adjustment error

013 : Emergency stop

014 : Reverse limit error

015 : Forward limit error

016 : IGBT overheat

- 017 : Abnormal EEPROM
  - 018 : Abnormal signal output
  - 019 : Serial communication error
  - 020 : Serial communication time out
  - 021 : Reserved
  - 022 : Main circuit power lack phase
  - 023 : Early warning for overload
  - 024 : Encoder initial magnetic field error (The magnetic field of the encoder U,V, W signal is in error)
  - 025 : The internal of the encoder is in error. (The internal memory of the encoder and the internal counter are in error)
  - 026 : Unreliable internal data of the encoder
  - 027 : Encoder reset error
  - 028 : The encoder is over voltage or the internal of the encoder is in error
  - 029 : Gray code error
  - 030 : Motor crash error
  - 031 : Incorrect wiring of the motor power line U, V, W (Incorrect wiring of the motor power line U, V, W, GND)
  - 034 : Internal communication of the encoder is in error
  - 040 : Excessive deviation of full closed-loop position control
  - 041 : Communication of CN5 is breakdown
  - 042 : Analog input voltage error
  - 044 : Warning of servo drive function overload
  - 060 : The absolute position is lost
  - 061 : Encoder under voltage
  - 062 : The multi-turn of absolute encoder overflows
  - 068 : Absolute data transmitted via I/O is in error
  - 069 : Wrong motor type
  - 099 : DSP firmware upgrade
- Alarm of CANopen Communication
- 111 : CANopen SDO receives buffer overflow
  - 112 : CANopen PDO receives buffer overflow
  - 121 : Index error occurs when accessing CANopen PDO

- 122 : Sub-Index error occurs when accessing CANopen PDO
- 123 : Data size error occurs when accessing CANopen PDO
- 124 : Data range error occurs when accessing CANopen PDO
- 125 : CANopen PDO mapping object is read-only and write-protected.
- 126 : CANopen PDO mapping object is not allowed in PDO
- 127 : CANopen PDO mapping object is write-protected when Servo ON
- 128 : Error occurs when reading CANopen PDO mapping object via EEPROM
- 129 : Error occurs when writing CANopen PDO mapping object via EEPROM
- 130 : The accessing address of EEPROM is out of range when using CANopen PDO mapping object
- 131 : CRC of EEPROM calculation error occurs when using CANopen PDO mapping object
- 132 : Enter the incorrect password when using CANopen PDO mapping object
- 185 : Abnormal CAN Bus hardware

#### Alarm of Motion

- 201 : An error occurs when loading CANopen data
- 207 : Parameter group of PR#8 is out of range
- 209 : Parameter number of PR#8 is out of range
- 213 ~ 219 : An error occurs when writing parameter via PR procedure.  
Please refer to Chapter 11 of the manual for further information.
- 231 : The setting of monitor item of PR#8 is out of range
- 235 : PR command overflows
- 237 : Indexing coordinate is undefined
- 245 ~ 277 : Reserved
- 283 : Forward software limit
- 285 : Reverse software limit
- 289 : Feedback position counter overflows
- 291 : Servo OFF error
- 301 : CANopen fails to synchronize
- 302 : The synchronized signal of CANopen is sent too fast
- 303 : The synchronized signal of CANopen is sent too slow
- 304 : CANopen IP command is failed

305 : SYNC Period is in error

380 : Position Deviation Alarm of DO.MC\_OK. Please refer to parameter P1-48.

P0-02	STS	Drive Status		Address: 0004H 0005H
	Operational Interface :	Panel / Software	Communication	Related Section: 7.2
Default :	00			
Control Mode :	ALL			
Unit :	-			
Range :	00 ~ 127			
Data Size :	16-bit			
Format :	Decimal			

- Settings :
- 00 : Motor feedback pulse number (after the scaling of electronic gear ratio) [PUU]
  - 01 : Input pulse number of pulse command (after the scaling of electronic gear ratio) [PUU]
  - 02 : Deviation between control command pulse and feedback pulse number[PUU]
  - 03 : The number of motor feedback pulse [Encoder unit, 1,280,000 Pulse/rev]
  - 04 : Distance to command terminal (Encoder unit) [Pulse]
  - 05 : Error pulse number (after the scaling of electronic gear ratio) (Encoder unit) [Pulse]
  - 06 : The frequency of pulse command input [Kpps]
  - 07 : Motor speed [r/min]
  - 08 : Speed command input [Volt]
  - 09 : Speed command input [r/min]
  - 10 : Torque command input [Volt]
  - 11 : Torque command input [%]
  - 12 : Average torque [%]
  - 13 : Peak torque [%]

- 14 : Main circuit voltage (BUS voltage) [Volt]
- 15 : Load/motor inertia ratio [0.1times]
- 16 : IGBT temperature
- 17 : The frequency of resonance suppression
- 18 : The distance from the current position to Z. The range of the value is between -5000 and +5000;

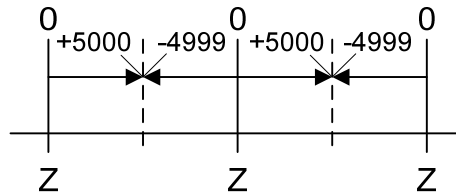

The interval of the two Z-phase pulse command if 10000 Pulse.

- 19 : Mapping Parameter #1 : P0 - 25
- 20 : Mapping Parameter #2 : P0 - 26
- 21 : Mapping Parameter #3 : P0 - 27
- 22 : Mapping Parameter #4 : P0 - 28
- 23 : Monitoring variable #1 : P0 - 09
- 24 : Monitoring variable #2 : P0 - 10
- 25 : Monitoring variable #3 : P0 - 11
- 26 : Monitoring variable #4 : P0 - 12
- 38 : It display the battery voltage [0.1 Volt]. For example, if it displays 36, it means the battery voltage is 3.6 V.
- 72 : Analog speed command [0.1 r/min] (This is supported by A2-M/-U/-L.)

<b>P0-03</b>	<b>MON</b>	<b>Analog Output Monitor</b>		<b>Address: 0006H 0007H</b>
	Operational Interface :	Panel / Software	Communication	Related Section: 6.6.4
	Default :	00		
	Control Mode :	ALL		
	Unit :	-		
	Range :	00 ~ 0x77		

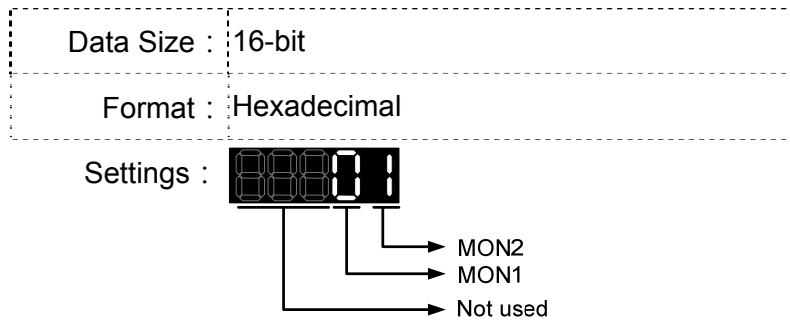

MON1, MON2 Setting Value	Description
0	Motor speed (+/-8 Volts/Max. speed)
1	Motor torque (+/-8 Volts/Max. torque)
2	Pulse command frequency (+8 Volts / 4.5Mpps)
3	Speed command (+/-8 Volts/ Max. speed command)
4	Torque command (+/-8 Volts/Max. torque command)
5	VBUS voltage (+/-8 Volts / 450V)
6	Reserved
7	Reserved

 **NOTE** Please refer to parameter P1-04, P1-05 for proportional setting of analog output voltage.

For example: P0-03 = 01 (MON1 is the analog output of motor speed; MON2 is the analog output of motor torque)

$$\text{MON1 output voltage} = 8 \times \frac{\text{Motor speed}}{(\text{Max. speed} \times \frac{P1-04}{100})} \text{ (unit : Volts)}$$

$$\text{MON2 output voltage} = 8 \times \frac{\text{Motor torque}}{(\text{Max. torque} \times \frac{P1-05}{100})}$$

(unit: Volts)

**P0-04 ~ P0-07**

**Reserved**

P0-08★	TSON	Power On Time	Address: 0010H 0011H
Operational Interface :	Panel / Software	Communication	Related Section : -
Default :	0		
Control Mode :	-		
Unit :	Hour		
Range :	0 ~ 65535		
Data Size :	16-bit		
Format :	Decimal		

Settings : It shows the total startup time of the servo drive.

P0-09★	CM1	Status Monitor Register 1	Address: 0012H 0013H
Operational Interface :	Panel / Software	Communication	Related Section: 4.3.5
Default :	-		
Control Mode :	ALL		
Unit :	-		
Range :	-		
Data Size :	32-bit		
Format :	Decimal		

Settings : The setting value which is set by P0-17 should be monitored via P0-09. (Please refer to Chapter 7.2.1, Description of Monitoring Variable for the setting value.)

For example, if P0-17 is set to 3, when accessing P0-09, it obtains the total feedback pulse number of motor encoder. For MODBUS communication, two 16-bit data, 0012H and 0013H will be read as a 32-bit data; (0013H : 0012H) = (Hi-word : Low-word).

Set P0-02 to 23, the panel displays **VAR-1** first, and then shows the content of P0-09.

<b>P0-10★</b>	<b>CM2</b>	<b>Status Monitor Register 2</b>	<b>Address: 0014H 0015H</b>
---------------	------------	----------------------------------	---------------------------------

Operational Interface :	Panel / Software	Communication	Related Section: 4.3.5
-------------------------	------------------	---------------	---------------------------

Default :	-
-----------	---

Control Mode :	ALL
----------------	-----

Unit :	-
--------	---

Range :	-
---------	---

Data Size :	32-bit
-------------	--------

Format :	Decimal
----------	---------

Settings : The setting value which is set by P0-18 should be monitored via P0-10. (Please refer to Chapter 7.2.1, Description of Monitoring variable for the setting value.) Set P0-02 to 24, the panel displays **VAR-2** first, and then shows the content of P0-10.

<b>P0-11★</b>	<b>CM3</b>	<b>Status Monitor Register 3</b>	<b>Address: 0016H 0017H</b>
---------------	------------	----------------------------------	---------------------------------

Operational Interface :	Panel / Software	Communication	Related Section: 4.3.5
-------------------------	------------------	---------------	---------------------------

Default :	-
-----------	---

Control Mode :	ALL
----------------	-----

Unit :	-
--------	---

Range :	-
---------	---

Data Size :	32-bit
-------------	--------

Format :	Decimal
----------	---------

Settings : The setting value which is set by P0-19 should be monitored via P0-11. (Please refer to Chapter 7.2.1, Description of Monitoring Variable for the setting value.) Set P0-02 to 25, the panel displays **VAR-3** first, and then shows the content of P0-11.



<b>P0-12★</b>	<b>CM4</b>	<b>Status Monitor Register 4</b>	<b>Address: 0018H 0019H</b>
	Operational Interface :	Panel / Software	Communication
	Default :	-	
	Control Mode :	ALL	
	Unit :	-	
	Range :	-	
	Data Size :	32-bit	
	Format :	Decimal	
<p>Settings : The setting value which is set by P0-20 should be monitored via P0-12. (Please refer to Chapter 7.2.1, Description of Monitoring Variable for the setting value.) Set P0-02 to 26, the panel displays <b>VAR-4</b> first, and then shows the content of P0-12.</p>			

<b>P0-13★</b>	<b>CM5</b>	<b>Status Monitor Register 5</b>	<b>Address: 001AH 001BH</b>
	Operational Interface :	Panel / Software	Communication
	Default :	-	
	Control Mode :	ALL	
	Unit :	-	
	Range :	-	
	Data Size :	32-bit	
	Format :	Decimal	
<p>Settings : The setting value which is set by P0-21 should be monitored via P0-13. (Please refer to Chapter 7.2.1, Description of Monitoring Variable for the setting value.)</p>			

<b>P0-14 ~ P0-16</b>	<b>Reserved</b>
----------------------	-----------------

P0-17	CM1A	Status Monitor Register 1 Selection	Address: 0022H 0023H
Operational Interface :		Panel / Software	Communication
Default :		0	
Control Mode :		-	
Unit :		-	
Range :		0 ~ 127	
Data Size :		16-bit	
Format :		Decimal	
Settings : Please refer to Chapter 7.2.1, Description of Monitoring Variable for the setting value. For example, if P0-17 is set to 07, then reading P0-09 means reading 「 Motor speed (r/min) 」 .			

P0-18	CM2A	Status Monitor Register 2 Selection	Address: 0024H 0025H
Operational Interface :		Panel / Software	Communication
Default :		0	
Control Mode :		-	
Unit :		-	
Range :		0 ~ 127	
Data Size :		16-bit	
Format :		Decimal	
Settings : Please refer to Chapter 7.2.1, Description of Monitoring Variable for the setting value.			

<b>P0-19</b>	<b>CM3A</b>	<b>Status Monitor Register 3 Selection</b>	<b>Address:0026H 0027H</b>
	Operational Interface :	Panel / Software      Communication	Related Section: -
	Default :	0	
	Control Mode :	-	
	Unit :	-	
	Range :	0 ~ 127	
	Data Size :	16-bit	
	Format :	Decimal	
Settings :	Please refer to Chapter 7.2.1, Description of Monitoring Variable for the setting value.		

<b>P0-20</b>	<b>CM4A</b>	<b>Status Monitor Register 4 Selection</b>	<b>Address: 0028H 0029H</b>
	Operational Interface :	Panel / Software      Communication	Related Section: -
	Default :	0	
	Control Mode :	-	
	Unit :	-	
	Range :	0 ~ 127	
	Data Size :	16-bit	
	Format :	Decimal	
Settings :	Please refer to Chapter 7.2.1, Description of Monitoring Variable for the setting value.		

<b>P0-21</b>	<b>CM5A</b>	<b>Status Monitor Register 5 Selection</b>	<b>Address: 002AH 002BH</b>
	Operational Interface :	Panel / Software      Communication	Related Section: -
	Default :	0	
	Control Mode :	-	
	Unit :	-	

Range :	0 ~ 127
Data Size :	16-bit
Format :	Decimal
Settings :	Please refer to Chapter 7.2.1, Description of Monitoring Variable for the setting value.

**P0-22 ~  
P0-24**

Reserved

**P0-25**

**MAP1**

**Mapping Parameter # 1**

**Address: 0032H  
0033H**

Operational  
Interface :

Panel / Software

Communication

Related Section:  
4.3.5

Default : No need to initialize

Control  
Mode : ALL

Unit : -

Range : determined by the corresponding parameter  
of P0-35

Data Size : 32-bit

Format : Hexadecimal

Settings : Users can rapidly continuously read and write parameters that are not in the same group. The content of parameter that is specified by P0-35 will be shown in P0-25.

Please refer to the description of P0-35 for parameter setting.

**P0-26**

**MAP2**

**Mapping Parameter # 2**

**Address: 0034H  
0035H**

Operational  
Interface :

Panel / Software

Communication

Related Section:  
4.3.5

Default : No need to initialize

Control  
Mode : ALL

Unit : -

Range : determined by the corresponding parameter  
of P0-36

Data Size : 32-bit

Format : Hexadecimal

Settings : The using method is the same as P0-25. The mapping target is set by parameter P0-36.

<b>P0-27</b>	<b>MAP3</b>	<b>Mapping Parameter # 3</b>		<b>Address: 0036H 0037H</b>
	Operational Interface :	Panel / Software	Communication	Related Section: 4.3.5
	Default :	No need to initialize		
	Control Mode :	ALL		
	Unit :	-		
	Range :	determined by the corresponding parameter of P0-37		
	Data Size :	32-bit		
	Format :	Hexadecimal		

Settings : The using method is the same as P0-25. The mapping target is set by parameter P0-37.

<b>P0-28</b>	<b>MAP4</b>	<b>Mapping Parameter # 4</b>		<b>Address: 0038H 0039H</b>
	Operational Interface :	Panel / Software	Communication	Related Section: 4.3.5
	Default :	No need to initialize		
	Control Mode :	ALL		
	Unit :	-		
	Range :	determined by the corresponding parameter of P0-38		
	Data Size :	32-bit		
	Format :	Hexadecimal		

Settings : The using method is the same as P0-25. The mapping target is set by parameter P0-38.

P0-29	MAP5	Mapping Parameter # 5	Address: 003AH 003BH
Operational Interface :		Panel / Software	Communication
Default :		No need to initialize	
Control Mode :		ALL	
Unit :		-	
Range :		determined by the corresponding parameter of P0-39	
Data Size :		32-bit	
Format :		Hexadecimal	
Settings : The using method is the same as P0-25. The mapping target is set by parameter P0-39.			

P0-30	MAP6	Mapping Parameter # 6	Address: 003CH 003DH
Operational Interface :		Panel / Software	Communication
Default :		No need to initialize	
Control Mode :		ALL	
Unit :		-	
Range :		determined by the corresponding parameter of P0-40	
Data Size :		32-bit	
Format :		Hexadecimal	
Settings : The using method is the same as P0-25. The mapping target is set by parameter P0-40.			

P0-31	MAP7	Mapping Parameter # 7	Address: 003EH 003FH
Operational Interface :		Panel / Software	Communication
Default :		No need to initialize	
Control Mode :		ALL	

Unit :	-
Range :	determined by the corresponding parameter of P0-41
Data Size :	32-bit
Format :	Hexadecimal

Settings : The using method is the same as P0-25. The mapping target is set by parameter P0-41.

<b>P0-32</b>	<b>MAP8</b>	<b>Mapping Parameter # 8</b>	<b>Address: 0040H 0041H</b>	
	Operational Interface :	Panel / Software      Communication	Related Section: 4.3.5	
	Default :	No need to initialize		
	Control Mode :	ALL		
	Unit :	-		
	Range :	determined by the corresponding parameter of P0-42		
	Data Size :	32-bit		
	Format :	Hexadecimal		
Settings :	The using method is the same as P0-25. The mapping target is set by parameter P0-42.			

<b>P0-33 ~ P0-34</b>	<b>Reserved</b>
----------------------	-----------------

<b>P0-35</b>	<b>MAP1A</b>	<b>Target Setting of Mapping Parameter P0-25</b>	<b>Address: 0046H 0047H</b>	
	Operational Interface :	Panel / Software      Communication	Related Section: 4.3.5	
	Default :	0x0		
	Control Mode :	ALL		
	Unit :	-		
	Range :	determined by the communication address of the parameter group		
	Data Size :	32-bit		
	Format :	Hexadecimal		

Settings : Select the data block to access the parameter corresponded by register 1.

The mapping content is 32 bits wide and can map to two 16-bit parameters or one 32-bit parameter.

P0-35:

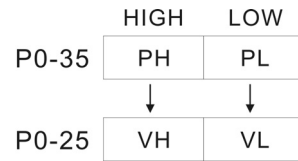

Mapping parameter: P0-35; Mapping content: P0-25.

When PH≠PL, it means the content of P0-25 includes two 16-bit parameters.

VH=\*(PH), VL=\*(PL)

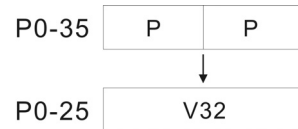

Mapping parameter: P0-35; Mapping content: P0-25.

When PH=PL=P, it means the content of P0-25 includes one 32-bit parameter.

If P=060Ah (parameter P6-10), then V32 is P6-10.

The setting format of PH, PL is:

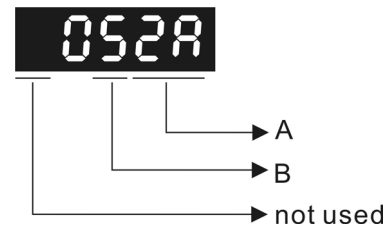

A: The hexadecimal of parameter indexing

B: The hexadecimal of parameter group

For example:

If the mapping target is P2-06, set P0-35 to 0206.

If the mapping target is P5-42, set P0-35 to 052A.

For example:

If users desire to read / write P1-44 (32-bit) through P0-25, set P0-35 to 0x012C012C via panel or communication. Then, when reading / writing P0-25, it also reads / writes P1-44.

Moreover, users can also access the value of P2-02 and P2-04 through P0-25.

P2-02 Position feed forward gain (16-bit)

P2-04 Speed control gain (16-bit)

Users only need to set P0-35 to 0x02040202. Then, when reading / writing P0-25, it also reads / writes the value of P2-02 and P2-04.



<b>P0-36</b>	<b>MAP2A</b>	<b>Target Setting of Mapping Parameter P0-26</b>	<b>Address: 0048H 0049H</b>
	Operational Interface :	Panel / Software	Communication
	Default :	0x0	
	Control Mode :	ALL	
	Unit :	-	
	Range :	determined by the communication address of the parameter group	
	Data Size :	32-bit	
	Format :	Hexadecimal	
Settings :	P0-36 <input type="text"/> ↓ ↓ P0-26 <input type="text"/>		Related Section: 4.3.5

<b>P0-37</b>	<b>MAP3A</b>	<b>Target Setting of Mapping Parameter P0-27</b>	<b>Address: 004AH 004BH</b>
	Operational Interface :	Panel / Software	Communication
	Default :	0x0	
	Control Mode :	ALL	
	Unit :	-	
	Range :	determined by the communication address of the parameter group	
	Data Size :	32-bit	
	Format :	Hexadecimal	
Settings :	P0-37 <input type="text"/> ↓ ↓ P0-27 <input type="text"/>		Related Section: 4.3.5

P0-38	MAP4A	Target Setting of Mapping Parameter P0-28	Address: 004CH 004DH
Operational Interface :		Panel / Software	Related Section: 4.3.5
		Communication	
Default :		0x0	
Control Mode :		ALL	
Unit :		-	
Range :		determined by the communication address of the parameter group	
Data Size :		32-bit	
Format :		Hexadecimal	
Settings :		P0-38 <input type="text"/> ↓       ↓ P0-28 <input type="text"/>	

P0-39	MAP5A	Target Setting of Mapping Parameter P0-29	Address: 004EH 004FH
Operational Interface :		Panel / Software	Related Section: 4.3.5
		Communication	
Default :		0x0	
Control Mode :		ALL	
Unit :		-	
Range :		determined by the communication address of the parameter group	
Data Size :		32-bit	
Format :		Hexadecimal	
Settings :		P0-39 <input type="text"/> ↓       ↓ P0-29 <input type="text"/>	

<b>P0-40</b>	<b>MAP6A</b>	<b>Target Setting of Mapping Parameter P0-30</b>		<b>Address: 0050H 0051H</b>
	Operational Interface :	Panel / Software	Communication	Related Section: 4.3.5
	Default :	0x0		
	Control Mode :	ALL		
	Unit :	-		
	Range :	determined by the communication address of the parameter group		
	Data Size :	32-bit		
	Format :	Hexadecimal		
Settings :	P0-40 <input style="width: 100px; height: 20px;" type="text"/> <div style="text-align: center; margin: 5px 0;">↓            ↓</div> P0-30 <input style="width: 100px; height: 20px;" type="text"/>			

<b>P0-41</b>	<b>MAP7A</b>	<b>Target Setting of Mapping Parameter P0-31</b>		<b>Address: 0052H 0053H</b>
	Operational Interface :	Panel / Software	Communication	Related Section: 4.3.5
	Default :	0x0		
	Control Mode :	ALL		
	Unit :	-		
	Range :	determined by the communication address of the parameter group		
	Data Size :	32-bit		
	Format :	Hexadecimal		
Settings :	P0-41 <input style="width: 100px; height: 20px;" type="text"/> <div style="text-align: center; margin: 5px 0;">↓            ↓</div> P0-31 <input style="width: 100px; height: 20px;" type="text"/>			

<b>P0-42</b>	<b>MAP8A</b>	<b>Target Setting of Mapping Parameter P0-32</b>	<b>Address: 0054H 0055H</b>
	Operational Interface :	Panel / Software      Communication	Related Section: 4.3.5
	Default :	0x0	
	Control Mode :	ALL	
	Unit :	-	
	Range :	determined by the communication address of the parameter group	
	Data Size :	32-bit	
	Format :	Hexadecimal	
	Settings :	P0-42 <input type="text"/> ↓           ↓ P0-32 <input type="text"/>	

<b>P0-43</b>	<b>Reserved</b>
--------------	-----------------

<b>P0-44★</b>	<b>PCMN</b>	<b>Status Monitor Register (for PC software)</b>	<b>Address: 0058H 0059H</b>
	Operational Interface :	Panel / Software      Communication	Related Section: 4.3.5
	Default :	0x0	
	Control Mode :	ALL	
	Unit :	-	
	Range :	determined by the communication address of the parameter group	
	Data Size :	32-bit	
	Format :	Decimal	
	Settings :	Same as parameter P0-09.	

P0-45■	PCMNA	Status Monitor Register Selection (for PC software)	Address: 005AH 005BH
	Operational Interface :	Panel / Software      Communication	Related Section: 4.3.5
	Default :	0x0	
	Control Mode :	ALL	
	Unit :	-	
	Range :	0~127	
	Data Size :	16-bit	
	Format :	Decimal	
	Settings :	Same as parameter P0-17	

P0-46★	SVSTS	Servo Digital Output Status Display	Address: 005CH 005DH
	Operational Interface :	Panel / Software      Communication	Related Section: -
	Default :	0	
	Control Mode :	ALL	
	Unit :	-	
	Range :	0x00 ~ 0xFF	
	Data Size :	16-bit	
	Format :	Hexadecimal	
	Settings :	Bit 0: SRDY (Servo is ready) Bit 1: SON (Servo ON) Bit 2: ZSPD (Zero speed detection) Bit 3: TSPD (Target speed reached) Bit 4: TPOS (Target position reached) Bit 5: TQL (Torque limiting) Bit 6: ALRM (Servo alarm) Bit 7: BRKR (Brake control output) Bit 8: HOME (Homing finished) Bit 9: OLW (Early warning for overload) Bit 10: WARN (When Servo warning, CW, CCW, EMGS, under voltage, Communication error, etc., occurs, DO is ON) Bit 11 ~ Bit 15: Reserved	

<b>P0-49</b> ■	<b>UAP</b>	<b>Renew Encoder Absolute Position</b>	<b>Address: 0062H 0063H</b>
	Operational Interface :	Panel / Software	Communication
	Default :	0x0	
	Control Mode :	ALL	
	Unit :	N/A	
	Range :	0x00 ~ 0x02	
	Data Size :	16-bit	
	Format :	Hexadecimaldecimal	

Settings : This parameter is used to renew the absolute position data of the encoder.



Parameter Renew Setting:

- 1: Renew the encoder data to parameters P0-50~P0-52 only.
- 2: Renew the parameters P0-50~P0-52, and clear the position error as well. While this setting is activated, the current position of the motor will be reset as the target position of position command (same function as CCLR).

<b>P0-50</b> ★	<b>APSTS</b>	<b>Absolute Coordinate System Status</b>	<b>Address: 0064H 0065H</b>
	Operational Interface :	Panel / Software	Communication
	Default :	0x0	
	Control Mode :	ALL	
	Unit :	N/A	
	Range :	0x00 ~ 0x1F	
	Data Size :	16-bit	
	Format :	Hexadecimal	

Settings :

Bit 7	Bit 6	Bit 5	Bit 4	Bit 3	Bit 2	Bit 1	Bit 0
Bit 15	Bit 14	Bit 13	Bit 12	Bit 11	Bit 10	Bit 9	Bit 8

Bit 0: Absolute position status  
 0: Normal  
 1: Absolute position is lost  
 Bit 1: Voltage level of battery  
 0: Normal  
 1: Low battery  
 Bit 2: Status of encoder multiturn  
 0: Normal  
 1: Overflow  
 Bit 3: Status of PUU  
 0: Normal  
 1: Overflow  
 Bit 4: Absolute coordinate system status  
 0: Normal  
 1: Absolute coordinate system has not been set  
 Bit 5 ~ Bit 15: Reserved. Must be set to 0.

<b>P0-51★</b>	<b>APR</b>	<b>Encoder Absolute Position (Multiturn)</b>	<b>Address: 0066H 0067H</b>
	Operational Interface :	Panel / Software	Communication
	Default :	0x0	
	Control Mode :	ALL	
	Unit :	rev	
	Range :	-32768 ~ +32767	
	Data Size :	32-bit	
	Format :	Decimal	

Related Section: N/A

Settings : While the Bit 1 of P2-70 is set to 1 to read the encoder pulse number, this parameter represents the turns of encoder absolute position. While the Bit 1 of P2-70 is set to 0 to read the PUU number, this parameter becomes disabled and the setting value of this parameter is 0.

<b>P0-52★</b>	<b>APP</b>	<b>Encoder Absolute Position (Pulse number within Single turn or PUU)</b>	<b>Address: 0068H 0069H</b>
---------------	------------	---	---------------------------------

Operational Interface :	Panel / Software	Communication	Related Section: N/A
Default :	0x0		
Control Mode :	ALL		
Unit :	Pulse or PUU		
Range :	0~1280000-1 (Pulse Number); -2147483648 ~ 2147483647 (PUU)		
Data Size :	32-bit		
Format :	Decimal		

Settings : While the Bit 1 of P2-70 is set to 1 to read the pulse number, this parameter represents the pulse number of encoder absolute position. While the Bit 1 of P2-70 is set to 0 to read the PUU number, this parameter represents PUU number of motor absolute position.

<b>P0-53</b>	<b>ZDRT</b>	<b>General Range Compare Digital Output – Filtering Time</b>	<b>Address: 006AH 006BH</b>
--------------	-------------	--	---------------------------------

Operational Interface :	Panel / Software	Communication	Related Section: N/A
Default :	0x0000		
Control Mode :	ALL		
Unit :	ms		
Range :	0x0000 ~ 0x000F		
Data Size :	16-bit		
Format :	Hexadecimal		

Settings :

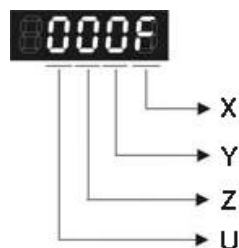

X: Filtering time for 1st monitoring variable

UYZ: Reserved

While the value of the monitoring variable is changed within the range between the setting values of P0-54 and P0-55, this parameter is used



to set the filter timing for the monitoring variable. The value of monitoring variable will output after the filtering time determined by parameter P0-53.

For example: when P0-09 is used

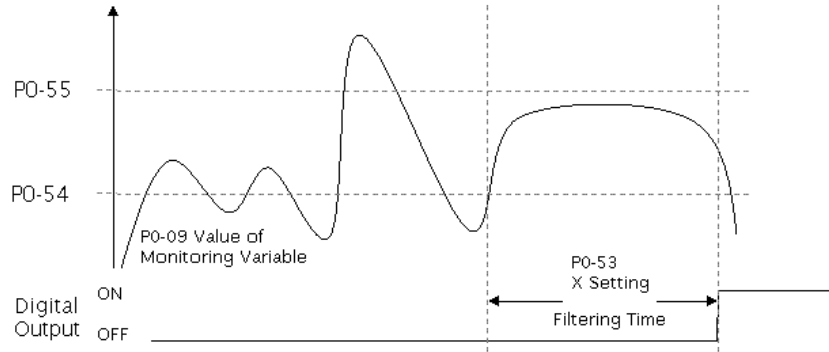

<b>P0-54</b>	<b>ZON1L</b>	<b>General Range Compare Digital Output – Lower Limit of 1st Monitoring Variable</b>	<b>Address: 006CH 006DH</b>
--------------	--------------	--	---------------------------------

Operational Interface :	Panel / Software	Communication	Related Section: N/A
Default :	0		
Control Mode :	ALL		
Unit :	-		
Range :	-2147483648 ~ +2147483647		
Data Size :	32-bit		
Format :	Decimal		

Settings : The value of parameter P0-09 will change within the range between P0-54 and P0-55 and then output after the filtering time determined by parameter P0-53.

<b>P0-55</b>	<b>ZON1H</b>	<b>General Range Compare Digital Output – Upper Limit of 1st Monitoring Variable</b>	<b>Address: 006EH 006FH</b>
--------------	--------------	--	---------------------------------

Operational Interface :	Panel / Software	Communication	Related Section: N/A
Default :	0		
Control Mode :	ALL		
Unit :	-		
Range :	-2147483648 ~ +2147483647		
Data Size :	32-bit		

Format : Decimal

Settings : The value of parameter P0-09 will change within the range between P0-54 and P0-55 and then output after the filtering time determined by parameter P0-53.

**P0-56 ~  
P0-62**

Reserved

**P0-63**

**VGT**

**The Time when Voltage Exceeding 400V**

**Address: 007EH  
007FH**

Operational  
Interface :

Panel / Software

Communication

Related Section: N/A

Default : 0x0

Control  
Mode : ALL

Unit : ms

Range : 0x00000000 ~ 0x7FFFFFFF

Data Size : 32-bit

Format : Decimal

Settings : Record the accumulative time when the drive's voltage exceeding 400V.

P1-xx Basic Parameters

<b>P1-00▲</b>	<b>PTT</b>	<b>The Type of External Pulse Input</b>	<b>Address: 0100H 0101H</b>
	Operational Interface :	Panel / Software      Communication	Related Section: 6.2.1
	Default :	0x2	
	Control Mode :	PT	
	Unit :	-	
	Range :	0 ~ 0x1132	
	Data Size :	16-bit	
	Format :	Hexadecimal	

Settings :

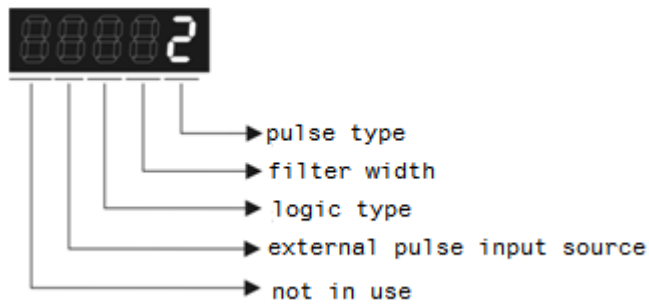

- Pulse Type
  - 0: AB phase pulse (4x)
  - 1: Clockwise (CW) and Counterclockwise (CCW) pulse
  - 2: Pulse + symbol
  - Other setting: reserved
- Filter Width
 

If the received frequency is much higher than the setting, it will be regarded as the noise and filtered out.

Setting Value	Min. pulse width*note1 (Low-speed filter frequency)	Setting Value	Min. pulse width*note1 (High-speed filter frequency)
0	600ns (0.83Mpps)	0	150ns (3.33Mpps)
1	2.4us (208Kpps)	1	600ns (0.83Mpps)
2	4.8us (104Kpps)	2	1.2us (416Kpps)
3	9.6us (52Kpps)	3	2.4us (208Kpps)
4	No filter function	4	No filter function

Note: When the source of external pulse is from the high-speed differential signal and the setting value is 0 (the high-speed filter frequency is 3.33Mpps at the moment), then:

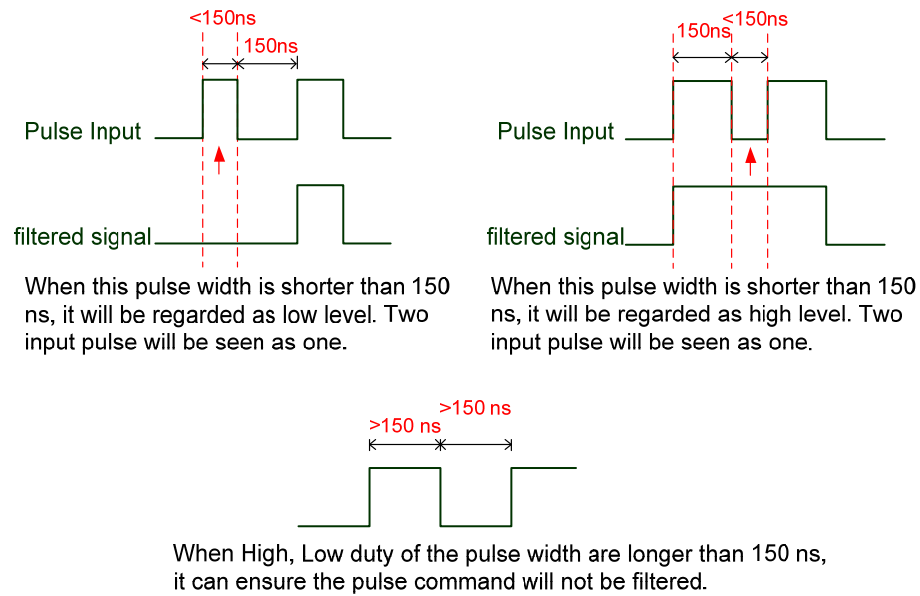

If the user uses 2~4 MHz input pulse, it is suggested to set the filter value to 4. Please note that the applicable version is: DSP version 1.036 sub05 and CPLD version above 10.

Note: When the signal is the high-speed pulse specification of 4 Mpps and the settings value of the filter is 4, then pulse will not be filtered.

● Logic Type

		High-speed and Low-speed pulse input	
Logic	Pulse Type	Forward	Reverse
0	AB phase pulse	<p>A Pulse Phase Lead</p>	<p>A Pulse Phase Lag</p>
	CW and CCW pulse		

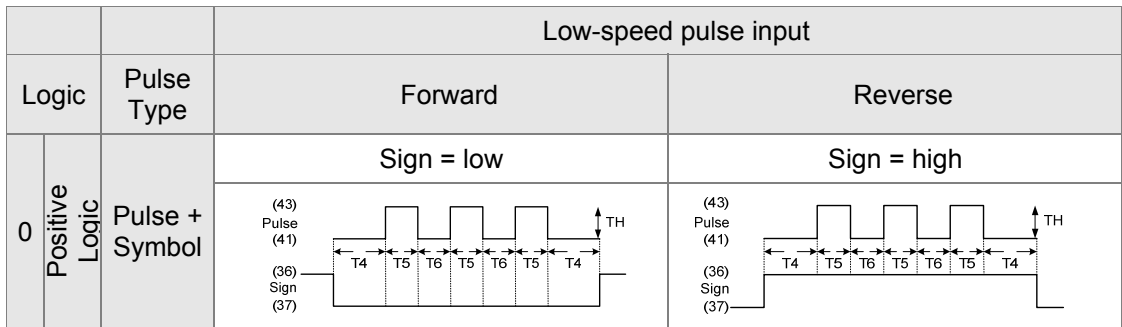
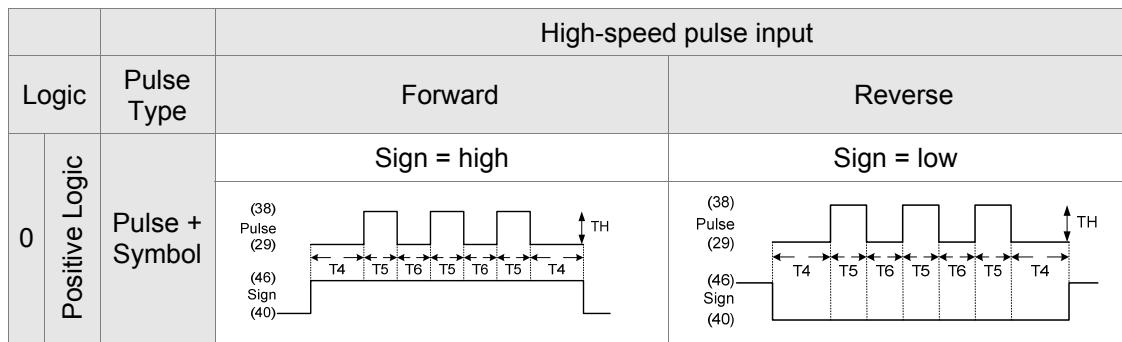

For digital circuit, it uses 0 and 1 represents two status, which is high voltage and low voltage. In Positive Logic, 1 represents high voltage and 0 represents low voltage and vice versa in Negative Logic.

For example:

Positive Logic

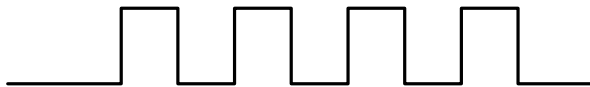

Negative Logic



Pulse Specification		Max. Input Frequency	Minimum time width					
			T1	T2	T3	T4	T5	T6
High-speed pulse	Differential Signal	4Mpps	62.5ns	125ns	250ns	200ns	125ns	125ns
Low-speed pulse	Differential Signal	500Kpps	0.5µs	1µs	2µs	2µs	1µs	1µs
	Open-collector	200Kpps	1.25µs	2.5µs	5µs	5µs	2.5µs	2.5µs

Pulse Specification		Max. Input Frequency	Voltage Specification	Forward Current
High-speed pulse	Differential Signal	4Mpps	5V	< 25mA
Low-speed pulse	Differential Signal	500Kpps	2.8V ~ 3.7V	< 25mA
	Open-collector	200Kpps	24V (Max.)	< 25mA

- The Source of External Pulse:  
0: Low-speed optical coupler (CN1 Pin: PULSE, SIGN)  
1: High-speed differential (CN1 Pin: HPULSE, HSIGN)

P1-01●	CTL	Input Setting of Control Mode and Control Command	Address : 0102H 0103H
	Operational Interface :	Panel / Software      Communication	Related Section: Section 6.1 Table 8.1
	Default :	0	
	Control Mode :	ALL	
	Unit :	P (pulse); S (r/min, m/s); T (N-M)	
	Range :	00 ~ 0x110F	
	Data Size :	16-bit	
	Format :	Hexadecimal	

Settings :

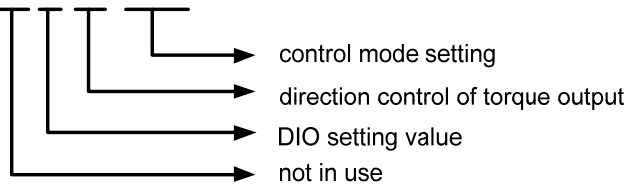
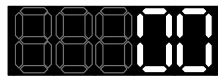

● Control Mode Settings

Mode	PT	PR	S	T	Sz	Tz
Single Mode						
00	▲					
01		▲				
02			▲			
03				▲		
04					▲	
05						▲
Dual Mode						
06	▲		▲			
07	▲			▲		
08		▲	▲			
09		▲		▲		
0A			▲	▲		
0B	CANopen Mode (work with Delta's PLC)					
	DMCNET Mode					
0C	CANopen Mode					
	EtherCAT Mode					
0D	▲	▲				
Multiple Mode						
0E	▲	▲	▲			
0F	▲	▲		▲	0F	

Dual Mode: It can switch mode via the external Digital Input (DI). For example, if it is set to the dual mode of PT/S (Control mode setting: 06), the mode can be switched via DI. S-P (Please refer to table 8.1).

Multiple Mode: It can switch mode via the external Digital Input (DI). For example, if it is set to multiple mode of PT/PR/S (Control Mode Setting: 12), the mode can be switched via DI. S-P, PT-PR (Please refer to table 8.1).

Torque Output Direction Settings

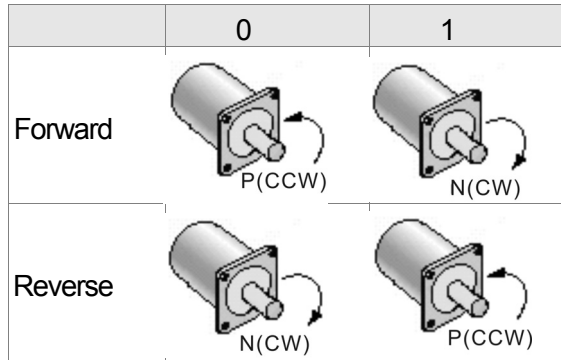

- Digital Input / Digital Output (DIO) Setting
  - 0: When switching mode, DIO (P2-10 ~ P2-22) remains the original setting value and will not be changed.
  - 1: When switching mode, DIO (P2-10 ~ P2-22) can be reset to the default value of each operational mode automatically.

P1-02▲	PSTL	Speed and Torque Limit Setting	Address: 0104H 0105H
Operational Interface :	Panel / Software	Communication	Related Section: Section 6.6 Table 8.1
Default :	0		
Control Mode :	ALL		
Unit :	-		
Range :	00 ~ 0x11		
Data Size :	16-bit		
Format :	Hexadecimal		

Settings :

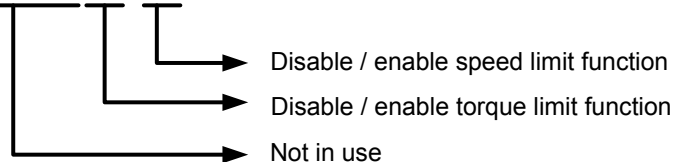
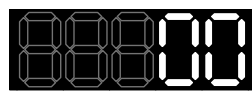

- Disable / enable speed limit function
    - 0: Disable speed limit function
    - 1: Enable speed limit function (it is effective in T / Tz mode only)
    - Other: Reserved
- Block diagram of speed limit setting:



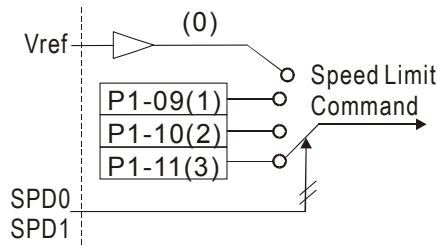

- Disable / enable torque limit function  
 0: Disable torque limit function  
 1: Enable torque limit function (it is effective in P / S / Sz mode)  
 Other: Reserved

Block diagram of torque limit setting:

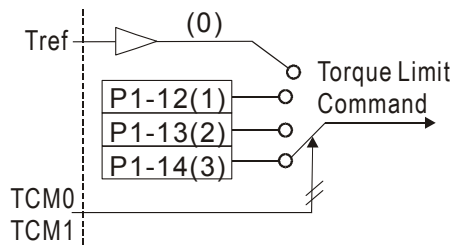

When desiring to use torque limit function, users could use parameter to set this value to 1 and limit the torque for good. Thus, the user can save one DI setting. Also, users could enable or disable the limit function via DI.TRQLM, which is a more flexible way but would need to take one DI setting. Torque limit can be enabled by P1-02 or DI. DI.TCM0 and DI.TCM1 are for selecting the limiting source.

P1-03	AOUT	Polarity Setting of Encoder Pulse Output	Address: 0106H 0107H
Operational Interface :	Panel / Software	Communication	Related Section: 3.3.3
Default :	0		
Control Mode :	ALL		
Unit :	-		
Range :	0 ~ 0x13		
Data Size :	16-bit		
Format :	Hexadecimal		

Settings :

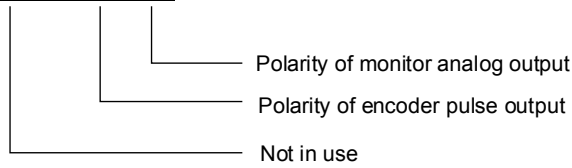

- Polarity of monitor analog output

0: MON1(+), MON2(+)	2: MON1(-), MON2(+)
1: MON1(+), MON2(-)	3: MON1(-), MON2(-)

- Polarity of encoder pulse output

0: Forward output	1: Reverse output
-------------------	-------------------

P1-04	MON1	MON1 Analog Monitor Output Proportion	Address: 0108H 0109H
Operational Interface :		Panel / Software	Communication
Default :		100	
Control Mode :		ALL	
Unit :		% (full scale)	
Range :		0 ~ 100	
Data Size :		16-bit	
Format :		Decimal	

Settings : Please refer to parameter P0-03 for the setting of analog output selection.

For example:

P0-03 = 0x00 (MON1 is the speed analog output)

When the output voltage value of MON1 is V1:

$$\text{Motor speed} = (\text{Max. speed} \times V1/8) \times P1-04/100$$

P1-05	MON2	MON2 Analog Monitor Output Proportion	Address: 0108H 0109H
Operational Interface :		Panel / Software	Communication
Default :		100	
Control Mode :		ALL	

Unit :	% (full scale)
Range :	0 ~ 100
Data Size :	16-bit
Format :	Decimal

Settings : Please refer to parameter P0-03 for the setting of analog output selection.  
 For example: P0-03 = 0x00 (MON2 is the speed analog output)  
 When the output voltage value of MON2 is V2: Motor speed = (Max. × V2/8) × P1-05/100

<b>P1-06</b>	<b>SFLT</b>	<b>Analog Speed Command (Low-pass Filter)</b>	<b>Address: 010CH 010DH</b>
--------------	-------------	---	---------------------------------

Operational Interface :	Panel / Software	Communication	Related Section: 6.3.3
-------------------------	------------------	---------------	---------------------------

Default : 0

Control Mode : S

Unit : ms

Range : 0 ~ 1000 (0: disable this function)

Data Size : 16-bit

Format : Decimal

Settings : 0: Disabled

<b>P1-07</b>	<b>TFLT</b>	<b>Analog Torque Command (Low-pass Filter)</b>	<b>Address: 010EH 010FH</b>
--------------	-------------	--	---------------------------------

Operational Interface :	Panel / Software	Communication	Related Section: 6.4.3
-------------------------	------------------	---------------	---------------------------

Default : 0

Control Mode : T

Unit : ms

Range : 0 ~ 1000 (0: disable this function)

Data Size : 16-bit

Format : Decimal

Settings : 0: Disabled

P1-08	PFLT	Smooth Constant of Position Command (Low-pass Filter)	Address: 0110H 0111H
	Operational Interface :	Panel / Software      Communication	Related Section: 6.2.6
	Default :	0	
	Control Mode :	PT / PR	
	Unit :	10 ms	
	Range :	0 ~ 1000	
	Data Size :	16-bit	
	Format :	Decimal	
	Example :	11 = 110 ms	
	Settings :	0: Disabled	

P1-09	SP1	Internal Speed Command 1 / Internal Speed Limit 1	Address: 0112H 0113H
	Operational Interface :	Panel / Software      Communication	Related Section: 6.3.1
	Default :	1000	
	Control Mode :	S / T	
	Unit :	0.1rpm	
	Range :	-60000 ~ +60000	
	Data Size :	32-bit	
	Format :	Decimal	
	Example :	Internal speed command: 120 = 12 r/min Internal Speed Limit: Positive value and negative value is the same. Please refer to the following description.	

Settings : Internal Speed Command 1: The setting of the first internal speed command

Internal Speed Limit 1: The setting of the first internal speed limit

Example of inputting internal speed limit:

Speed limit setting value of P1-09	Allowable Speed Range	Forward Speed Limit	Reverse Speed Limit
1000	-100 ~ 100 r/min	100 r/min	-100 r/min
-1000			

<b>P1-10</b>	<b>SP2</b>	<b>Internal Speed Command 2 / Internal Speed Limit 2</b>		<b>Address: 0114H 0115H</b>	
	Operational Interface :	Panel / Software	Communication	Related Section: 6.3.1	
	Default :	2000			
	Control Mode :	S / T			
	Unit :	0.1rpm			
	Range :	-60000 ~ +60000			
	Data Size :	32-bit			
	Format :	Decimal			
	Example :	Internal speed command: 120 = 12 r/min Internal Speed limit: Positive value and negative value is the same. Please refer to the following description.			

Settings : Internal Speed Command 2 : The setting of the 2<sup>nd</sup> internal speed command

Internal Speed Limit 2: The setting of the second internal speed limit

Example of inputting internal speed limit:

Speed limit setting value of P1-10	Allowable Speed Range	Forward Speed Limit	Reverse Speed Limit
1000	-100 ~ 100 r/min	100 r/min	-100 r/min
-1000			

<b>P1-11</b>	<b>SP3</b>	<b>Internal Speed Command 3 / Internal Speed Limit 3</b>		<b>Address: 0116H 0117H</b>
	Operational Interface :	Panel / Software	Communication	Related Section: 6.3.1
	Default :	3000		
	Control Mode :	S / T		
	Unit :	0.1rpm		
	Range :	-60000 ~ +60000		
	Data Size :	32-bit		
	Format :	Decimal		
Example :	Internal Speed Command: 120 = 12 r/min Internal Speed limit: Positive value and negative value is the same. Please refer to the following description.			

Settings : Internal Speed Command 3: The setting of the third internal speed command

Internal Speed Limit 3: The setting of the third internal speed limit

Example of inputting internal speed limit:

Speed limit setting of P1-11	Allowable Speed Range	Forward Speed Limit	Reverse Speed Limit
1000	-100 ~ 100 r/min	100 r/min	-100 r/min
-1000			

<b>P1-12</b>	<b>TQ1</b>	<b>Internal Torque Command 1 / Internal Torque Limit 1</b>		<b>Address: 0118H 0119H</b>
	Operational Interface :	Panel / Software	Communication	Related Section: 6.4.1
	Default :	100		
	Control Mode :	T / P, S		
	Unit :	%		
	Range :	-300 ~ +300		
	Data Size :	16-bit		
	Format :	Decimal		

Example : Internal Torque Command: 30 = 30 %  
 Internal Torque Limit: Positive value and negative value is the same. Please refer to the following description.

Settings : Internal Torque Command 1: The setting of the first internal torque command  
 Internal Torque Limit 1: The setting of the first internal torque limit

Example of inputting internal torque limit:

Torque limit setting value of P1-12	Allowable Torque Range	Forward Torque Limit	Reverse Torque Limit
30	-30 ~ 30 %	30 %	-30 %
-30			

<b>P1-13</b>	<b>TQ2</b>	<b>Internal Torque Command 2 / Internal Torque Limit 2</b>	<b>Address: 011AH 011BH</b>
	Operational Interface :	Panel / Software      Communication	Related Section: 6.4.1
	Default :	100	
	Control Mode :	T / P, S	
	Unit :	%	
	Range :	-300 ~ +300	
	Data Size :	16-bit	
	Format :	Decimal	
Example :	Internal Torque Command: 30 = 30 % Internal Torque Limit: Positive value and negative value is the same. Please refer to the following description.		

Settings : Internal Torque Command 2: The setting of the second internal torque command

Internal Torque Limit 2: The setting of the second internal torque limit

Example of inputting internal torque limit:

Torque limit setting value of P1-13	Allowable Torque Range	Forward Torque Limit	Reverse Torque Limit
30	-30 ~ 30 %	30 %	-30 %
-30			

<b>P1-14</b>	<b>TQ3</b>	<b>Internal Torque Command 3 / Internal Torque Limit 3</b>		<b>Address: 011CH 011DH</b>
	Operational Interface :	Panel / Software	Communication	Related Section: 6.4.1
	Default :	100		
	Control Mode :	T / P, S		
	Unit :	%		
	Range :	-300 ~ +300		
	Data Size :	16-bit		
	Format :	Decimal		
Example :	Internal Torque Command: 30 = 30 % Internal Torque Limit: Positive value and negative value is the same. Please refer to the following description.			

Settings : Internal Torque Command 3: The setting of the third internal torque command

Internal Torque Limit 3: The setting of the third internal torque limit

Example of inputting internal torque limit:

Torque limit setting value of P1-14	Allowable Torque Range	Forward Torque Limit	Reverse Torque Limit
30	-30 ~ 30 %	30 %	-30 %
-30			

<b>P1-15</b>	<b>CXFT</b>	<b>Capture Synchronous Axis – Threshold of Correction</b>		<b>Address: 011EH 011FH</b>
	Operational Interface :	Panel / Software	Communication	Related Section:
	Default :	0000h		
	Control Mode :	ALL		
	Unit :	-		
	Range :	0000h ~ 0x1F5F		
	Data Size :	16-bit		
	Format :	Hexadecimal		



Settings :

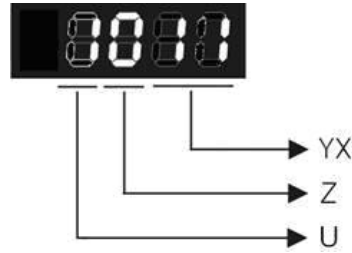

YX: Threshold of correction (%)

Z: Filter intensity

U: Filter is functioning (read-only)

(It will be provided after the version of V1.0.38 sub15)

YX: When synchronous axis captures the signal, the system will calculate the error. This function is enabled only when the error is less than the setting range. Otherwise, the system will use the new threshold of correction to perform the operation.

YX	00	01~05F
Function	Disabled	It will be enabled when error is between 1% and YX%.

Z	0	1~F
Function	Disabled	Average of 2^Z: Enabled

Z: The setting of filter intensity (Bigger value brings less severe change and better filter effect)

U: Value Definition (read-only):

0: Filter function is disabled. It means the error is greater than Y & X Range.

1: Filter function is enabled. It means the error is within Y & X range. If value Z or YX is 0, filter function is disabled.

<b>P1-16</b>	<b>CSOF</b>	<b>Capture Synchronous Axis – Offset Compensation</b>		<b>Address: 0120H 0121H</b>
	Operational Interface :	Panel / Software	Communication	Related Section:
	Default :	0		
	Control Mode :	PR		
	Unit :	Pulse unit of Capture Axis		
	Range :	-32768 ~ +32767		

Data Size :	16-bit
Format :	Decimal

Settings : When capture synchronous axis is enabled, if desire to change the synchronous error (P5-79), setting this parameter will do.

Write P1-16:  $P5-79 = P5-79 + \text{writing value}$

Read P1-16:  $\text{Read value} = P5-79$



**NOTE** 1) The setting value of this parameter is the accumulative value, which will not be influenced by current error value.

2) The value of P5-79 can be monitored by monitoring variable 0x54.

<b>P1-17</b>	<b>TEET</b>	<b>Compensation of Following Error - Additional Time Setting</b>	<b>Address: 0122H 0123H</b>
	Operational Interface :	Panel / Software      Communication	Related Section:

Default : 0

Control Mode : ALL

Unit : Ms; the smallest unit is usec

Range : -20.000 ~ +20.000 (three decimal point)

Data Size : 16-bit

Format : Decimal

Example : 1.5 = Motor speed x 1.5 ms (PUU)

Settings : When this function is enabled (P1-36 = 1), the system will make the position error (PUU) close to 0 according to the compensation amount of command. If the time delay is caused by other reasons, users could setup the additional compensation time to compensate the position error.

Additional compensation distance = P1-17 x Motor speed



**NOTE** 1) Value of P1-36 has to set to 1.

<b>P1-18</b>	<b>CPCT</b>	<b>Electronic Cam (E-Cam) Pulse Phase Compensation – Time Setting</b>		<b>Address: 0124H 0125H</b>
	Operational Interface :	Panel /Software	Communication	Related Section: N/A
	Default :	0		
	Control Mode :	PR		
	Unit :	ms with fraction down to usec		
	Range :	-20.000 ~ +20.000 (Three decimal point)		
	Data Size :	16-bit		
	Format :	Decimal		

Settings : (This function is available in firmware version V1.038 sub48 and later models only)

This parameter is used to compensate the delay pulse phase when the electronic cam function is enabled during operation. Please use this parameter with P1-21.

$$\text{Compensated Pulse Phase (pls)} = \text{P1-18} \times (\text{Pulse Frequency of E-Cam Master Axis (Kpps)} - \text{P1-21})$$

Please note:

1. The setting value of this parameter is proportioned to the value of the pulse frequency of E-Cam master axis.
2. The pulse phase compensation function is enabled only when the setting value of parameter P1-18 is not equal to 0.
3. The pulse phase compensation function is enabled only when the value of the pulse frequency of E-Cam master axis (monitoring variable is 060) Pulse number of E-Cam master axis (Incremental)) is higher than the setting value of parameter P1-21.

<b>P1-19</b>	<b>CPEX</b>	<b>CAPTURE / COMPARE – Additional Function Settings</b>		<b>Address: 0126H 0127H</b>
	Operational Interface :	Panel/Software	Communication	Related Section: N/A
	Default :	0		
	Control Mode :	ALL		
	Unit :	N/A		
	Range :	0x0000 ~ 0x0101		
	Data Size :	16-bit		

Format : Hexadecimal

Settings :

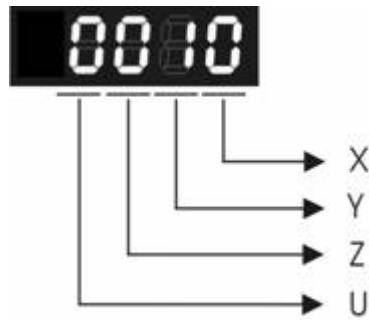

X: Bit settings of Capture additional function settings:

Bit	3	2	1	0
Function	-	-	-	Repeating Mode
Explanation	-	-	-	Enable the repeating mode. After the last position is captured, the system will automatically repeat this CAPTURE function. The captured data is still stored in the data array that the starting address is specified by P5-36! (This function is available in firmware version V1.038 sub19 and later models only)

Y: Reserved

Z: Bit settings of Compare additional function settings:

Bit	3	2	1	0
Function	-	-	-	Automatically set P1-24 to 0.
Explanation	-	-	-	When Bit0 is set to 1, P1-24 will only be effective once and reset to 0 automatically! Otherwise, the value of P1-24 will remain unchanged. (This function is available in firmware version V1.038 sub19 and later models only)

U: Reserved

P1-20	CPMK	CAPTURE – Masking Range Setting	Address: 0128H 0129H
Operational Interface :	Panel/Software	Communication	Related Section: N/A
Default :	0		
Control Mode :	ALL		
Unit :	The Pulse Unit of Capture Axis		
Range :	0 ~ +100000000		
Data Size :	32-bit		

Format : Decimal

Settings : When multiple points are required to be captured, after each point is captured, the masking range can be set in this parameter. In the masking area, the CAPTURE function will not work. The masking range is defined as follows:

$$(CAP\_DATA-P1-20 \cdot CAP\_DATA+P1-20)$$

Please note:

When the setting value of this parameter is set to 0, the masking function is disabled.

<b>P1-21</b>	<b>CPCL</b>	<b>E-Cam Pulse Phase Compensation – Min. Frequency Setting of Master Axis</b>		<b>Address: 012AH 012BH</b>
	Operational Interface :	Panel/Software	Communication	Related Section: N/A
	Default :	0		
	Control Mode :	PR		
	Unit :	Kpps (Kpulse/sec)		
	Range :	-32768 ~ +32767		
	Data Size :	16-bit		
	Format :	Decimal		

Settings : (This function is available in firmware version V1.038 sub48 and later models only)

This parameter is used to compensate the delay pulse phase when the electronic cam function is enabled during operation. Please use this parameter with P1-18.

$$\text{Compensated Pulse Phase (pls)} = P1-18 \times (\text{Pulse Frequency of E-Cam Master Axis (Kpps)} - P1-21)$$

Please note:

1. The setting value of this parameter is proportioned to the value of the pulse frequency of E-Cam master axis.
2. The pulse phase compensation function is enabled only when the setting value of parameter P1-18 is not equal to 0.
3. The pulse phase compensation function is enabled only when the value of the pulse frequency of E-Cam master axis (monitoring variable is 060) Pulse number of E-Cam master axis (Incremental)) is higher than the setting value of parameter P1-21.

P1-22	SPF1	PR Special Filter Settings	Address: 012CH 012DH
Operational Interface :	Panel/Software	Communication	Related Section: N/A
Default :	000h		
Control Mode :	PR		
Unit :	N/A		
Range :	0000h ~ 0x107F		
Data Size :	16-bit format = UZYX		
Format :	Hexadecimal		

Settings : YX: Acceleration time limit (0: Disabled, [1~127] x 10ms), Units: 10ms

Z: Reserved

U: Reverse inhibit (0: Disabled; 1: Enabled)

YX: The acceleration time limit is 0 ~ 1270 ms. When the changes of PR (or E-Cam) commands are too fast, it will cause the vibration of the mechanical system and affect the system performance. This function can be used to control the acceleration (deceleration) speed without exceeding the limit and can smooth the operation, reduce the noise and extend the system life.

This function is different from the general filter. The traditional one filter the command regardless the command change. This causes the delay of command delivered and reduces the efficiency of the system. This function can help to disable the filter function when the command changes within the limit. Then, the commands can be delivered without any time delay. The definition of this setting is the required acceleration time when the motor runs from 0 to 3000 r/min. The required time is longer, the effect of the filter function is better and the acceleration / deceleration will become smoother.

Please note:

The unit of acceleration time limit is 10ms. For example, if YX=12h, the acceleration time limit is 180ms. It means the filter function is enabled when the acceleration or deceleration time is faster than 180ms. Otherwise, the command will remain unchanged.

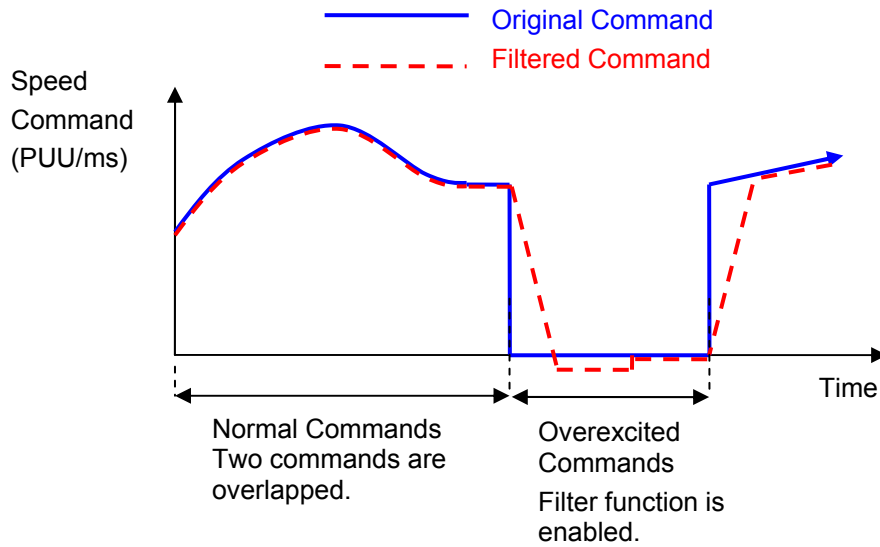

Note: When this filter function is enabled, it may cause the motor goes beyond the original position. Usually, the motor will return to the original position after the command becomes stable. However, if the command does not become stable, the internal position errors may be accumulated and result in AL.404.

Note: The filter time has to be set properly. It should be shorter than the acceleration time and longer than the abnormal command.

Note: The function of U item can be used to avoid the reverse operation.

U: Reverse Inhibit Function (0: Disable the function; 1: enable the function)

When this reverse inhibit function is enabled, the reverse command will be inhibited. The reverse command will be reserved and output after the received forward command exceeds the reserved reverse command.

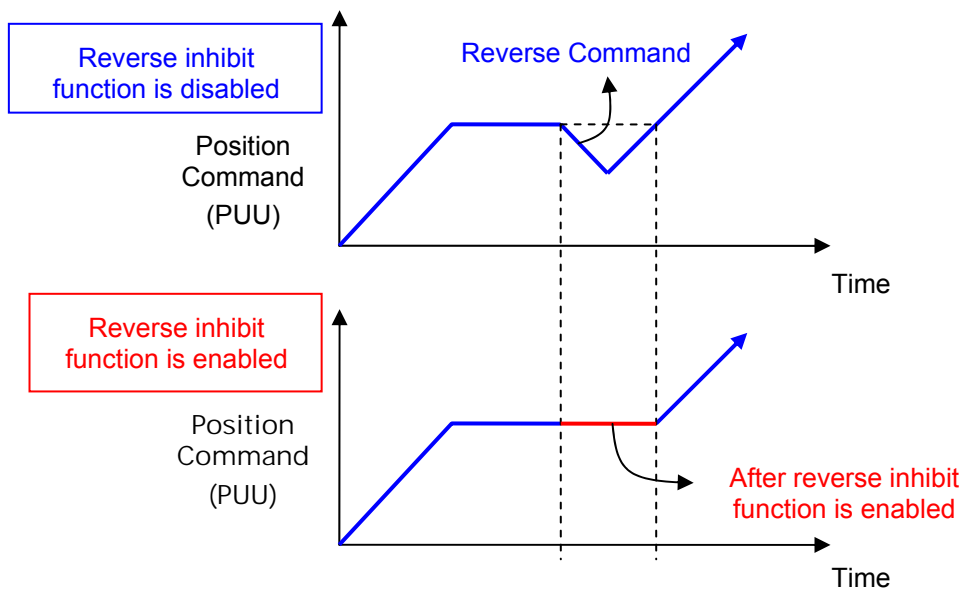

P1-23	CMOF	COMPARE - Offset Data of CMP (non-volatile)	Address: 012EH 012FH
Operational Interface :		Panel / Software	Communication
Default :		0	
Control Mode :		ALL	
Unit :		Pulse unit of compare source	
Range :		-10000000 ~ +10000000	
Data Size :		32-bit	
Format :		Decimal	
Settings : The real compared data is offset by this value.			

$$\text{CMP\_DATA} = \text{DATA\_ARRAY[*]} + \text{P1-23} + \text{P1-24}$$

**NOTE**

- 1 ) P1-23: Non-volatile parameter
- 2 ) P1-24: After setting, if P1-19.Z0 = 1, the value will be 0 automatically.
- 3 ) CMP\_DATA can be monitored via monitoring variable 0x25.

P1-24	CMOF	COMPARE - Offset Data of CMP (can reset to 0 automatically)	Address: 0130H 0131H
Operational Interface :		Panel / Software	Communication
Default :		0	
Control Mode :		ALL	
Unit :		Pulse unit of compare source	
Range :		-32768 ~ +32767	
Data Size :		16-bit	
Format :		Decimal	
Settings : The real compared data is offset by this value.			

$$\text{CMP\_DATA} = \text{DATA\_ARRAY[*]} + \text{P1-23} + \text{P1-24}$$

**NOTE**

- 1 ) P1-24: volatile parameter.
- 2 ) After setting, if P1-19.Z0 = 1, the value will be 0 automatically.



P1-25	VSF1	Low-frequency Vibration Suppression (1)	Address: 0132H 0133H
Operational Interface :		Panel / Software	Communication
Default :		1000	
Control Mode :		PT / PR	
Unit :		0.1 Hz	
Range :		10 ~ 1000	
Data Size :		16-bit	
Format :		Decimal	
Example :		150= 15 Hz	
Settings : The setting value of the first low-frequency vibration suppression. If P1-26 is set to 0, then it will disable the first low-frequency filter.			

P1-26	VSG1	Low-frequency Vibration Suppression Gain (1)	Address: 0134H 0135H
Operational Interface :		Panel / Software	Communication
Default :		0	
Control Mode :		PT / PR	
Unit :		-	
Range :		0 ~ 9 (0: Disable the first low-frequency filter)	
Data Size :		16-bit	
Format :		Decimal	
Settings : The first low-frequency vibration suppression gain. The bigger value it is, the better the position response will be. However, if the value is set too big, the motor will not be able to smoothly operate. It is suggested to set the value to 1.			

P1-27	VSF2	Low-frequency Vibration Suppression (2)	Address: 0136H 0137H
Operational Interface :	Panel / Software	Communication	Related Section: 6.2.9
Default :	1000		
Control Mode :	PT / PR		
Unit :	0.1 Hz		
Range :	10 ~ 1000		
Data Size :	16-bit		
Format :	Decimal		
Example :	150 = 15 Hz		
Settings :	The setting value of the second low-frequency vibration suppression. If P1-28 is set to 0, then it will disable the second low-frequency filter.		

P1-28	VSG2	Low-frequency Vibration Suppression Gain (2)	Address: 0138H 0139H
Operational Interface :	Panel / Software	Communication	Related Section: 6.2.9
Default :	0		
Control Mode :	PT / PR		
Unit :	-		
Range :	0 ~ 9 (0: Disable the second low-frequency filter)		
Data Size :	16-bit		
Format :	Decimal		
Settings :	The second low-frequency vibration suppression gain. The bigger value it is, the better the position response will be. However, if the value is set too big, the motor will not be able to smoothly operate. It is suggested to set the value to 1.		

P1-29	AVSM	Auto Low-frequency Vibration Supression Setting	Address: 013AH 013BH
Operational Interface :		Panel / Software	Communication
Default :		0	
Control Mode :		PT / PR	
Unit :		-	
Range :		0 ~ 1	
Data Size :		16-bit	
Format :		DEC	
Settings : 0: The function is disabled. 1: The value will set back to 0 after vibration suppression.			
Description of Auto Mode Setting: When the parameter is set to 1, it is in auto suppression. When the vibration frequency is not being detected or the value of searched frequency is stable, the parameter will set to 0 and save the low-frequency vibration suppression to P1-25 automatically.			

P1-30	VCL	Low-frequency Vibration Detection	Address: 013CH 013DH
Operational Interface :		Panel / Software	Communication
Default :		500	
Control Mode :		PT / PR	
Unit :		Pulse	
Range :		1 ~ 8000	
Data Size :		16-bit	
Format :		Decimal	
Settings : When enabling the auto suppression (P1-29 = 1), it will automatically search the detection level. The lower the value is, the more sensitive the detection will be. However, it is easy to misjudge the noise or regard the other low-frequency vibration as the suppression frequency. If the value is bigger, it will make more precise judgment. However, if the vibration of the mechanism is smaller, it might not detect the frequency of low-frequency vibration.			

<b>P1-31</b>	<b>Reserved</b>		
--------------	-----------------	--	--

<b>P1-32</b>	<b>LSTP</b>	<b>Motor Stop Mode</b>	<b>Address: 0140H 0141H</b>
--------------	-------------	------------------------	---------------------------------

Operational Interface :	Panel / Software	Communication	Related Section: -
Default :	0		
Control Mode :	ALL		
Unit :	-		
Range :	0 ~ 0x20		
Data Size :	16-bit		
Format :	Hexadecimal		

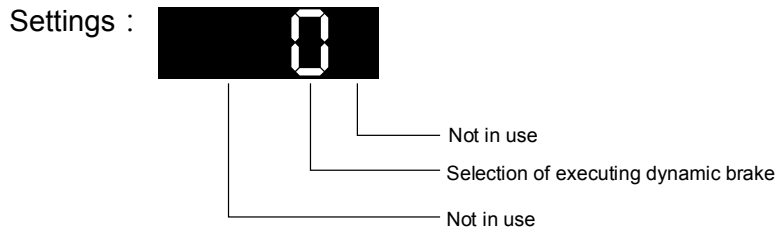

Selection of executing dynamic brake: Stop Mode when Servo Off or Alarm (including EMGS) occurs.

0: Execute dynamic brake

1: Motor free run

2: Execute dynamic brake first, then execute free run until it stops (The motor speed is slower than P1-38).

When PL and NL occur, please refer to event time setting value of P5-03 for determining the deceleration time. If the setting is 1 ms, it can stop instantaneously.

<b>P1-33</b>	<b>Reserved</b>		
--------------	-----------------	--	--

<b>P1-34</b>	<b>TACC</b>	<b>Acceleration Constant of S-Curve</b>	<b>Address: 0144H 0145H</b>
--------------	-------------	---	---------------------------------

Operational Interface :	Panel / Software	Communication	Related Section: 6.3.3
Default :	200		
Control Mode :	S		
Unit :	ms		

Range :	1 ~ 65500
Data Size :	16-bit
Format :	Decimal

Settings : Acceleration Constant of Rotary Motor:  
 The time that speed command accelerates from 0 to the rated speed.  
 Acceleration Constant of Linear Motor  
 The time that speed command accelerates from 0 to 5m/s.  
 P1-34, P1-35 and P1-36, the acceleration time of speed command from zero to the rated speed, all can be set individually. Even when P1-36 is set to 0, it still has acceleration / deceleration of trapezoid-curve.

-  **NOTE** 1 ) When the source of speed command is analog, and P1-36 is set to 0, it will disable S-curve function.
- 2 ) When the source of speed command is analog, the max. range of P1-34 will be set within 20000 automatically.

<b>P1-35</b>	<b>TDEC</b>	<b>Deceleration Constant of S-Curve</b>	<b>Address: 0146H 0147H</b>
	Operational Interface :	Panel / Software      Communication	Related Section: 6.3.3
	Default :	200	
	Control Mode :	S	
	Unit :	ms	
	Range :	1 ~ 65500	
	Data Size :	16-bit	
	Format :	Decimal	

Settings : Deceleration Constant of Rotary Motor:  
 The time that speed command decelerates from the rated speed to 0.  
 Deceleration Constant of Linear Motor:  
 The time that speed command decelerates from 5m/s to 0.  
 P1-34, P1-35 and P1-36, the deceleration time of speed command from the rated speed to zero, all can be set individually. Even when P1-36 is set to 0, it still has acceleration / deceleration of trapezoid-curve.

-  **NOTE** 1 ) When the source of speed command is analog, and P1-36 is set to 0, it will disable S-curve function.
- 2 ) When the source of speed command is analog, the max. range of P1-35 will be set within 20000 automatically.

<b>P1-36</b>	<b>TSL</b>	<b>Acceleration / Deceleration Constant of S-Curve</b>	<b>Address: 0148H 0149H</b>
	Operational Interface :	Panel / Software	Communication
	Default :	0	
	Control Mode :	S, PR	
	Unit :	ms	
	Range :	0 ~ 65500 (0: disable this function)	
	Data Size :	16-bit	
	Format :	Decimal	

Settings : Acceleration / Deceleration Constant of S-Curve:  
Speed

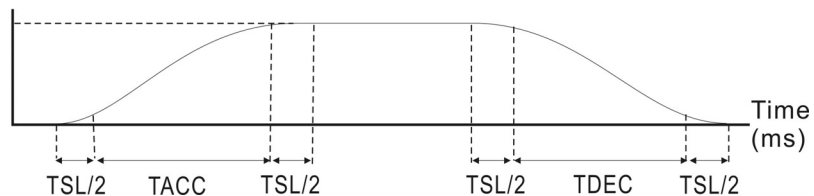

P1-34: Set the acceleration time of acceleration / deceleration of trapezoid-curve

P1-35: Set the deceleration time of acceleration / deceleration of trapezoid-curve

P1-36: Set the smoothing time of S-curve acceleration and deceleration

P1-34, P1-35 and P1-36 can be set individually. Even when P1-36 is set to 0, it still has acceleration / deceleration of trapezoid-curve.

Version after V1.036 sub00 provides the compensation function of following error.

	P1-36 = 0	P1-36 = 1	P1-36 > 1
Smoothing function of S-curve	Disable	Disable	Enable
Compensation function of following error	Disable	Enable	Determine by P2-68.X



**NOTE**

- 1 ) When the source of speed command is analog, and P1-36 is set to 0, it will disable S-curve function.
- 2 ) When the source of speed command is analog, the max. range of P1-36 will be set within 10000 automatically.

<b>P1-37</b>	<b>GDR</b>	<b>Inertia Ratio and Load Weight Ratio to Servo Motor</b>		<b>Address: 014AH 014BH</b>
	Operational Interface :	Panel / Software	Communication	Related Section: -
	Default :	1.0	10	
	Control Mode :	ALL		
	Unit :	1times	0.1times	
	Range :	0.0 ~ 200.0	0 ~ 2000	
	Data Size :	16-bit		
	Format :	One decimal	DEC	
	Example :	1.5 = 1.5 times	15 = 1.5 times	
	Settings :	Inertia ratio to servo motor (rotary motor): (J_load / J_motor) Among them: J_motor: Rotor inertia of the servo motor J_load: Total equivalent of inertia of external mechanical load. Total weight of movable section and load (linear motor) (will be available soon): (M_load+M_motor) Among them: M_motor: the weight of servo motor M_load: Total equivalent weight of mechanical loading		

<b>P1-38</b>	<b>ZSPD</b>	<b>Zero Speed Range Setting</b>		<b>Address: 014CH 014DH</b>
	Operational Interface :	Panel / Software	Communication	Related Section: Table 8.2
	Default :	10.0	100	
	Control Mode :	ALL		
	Unit :	1 r/min	0.1 r/min	
	Range :	0.0 ~ 200.0	0 ~ 2000	
	Data Size :	16-bit		
	Format :	One decimal	DEC	
	Example :	1.5 = 1.5 r/min	15 = 1.5 r/min	

Settings : Setting the output range of zero-speed signal (ZSPD). When the forward / reverse speed of the motor is slower than the setting value, the digital output will be enabled.

P1-39	SSPD	Target Motor Detection Level	Address: 014EH 014FH
	Operational Interface :	Panel / Software	Communication
	Default :	3000	
	Control Mode :	ALL	
	Unit :	r/min	
	Range :	0 ~ 5000	
	Data Size :	16-bit	
	Format :	Decimal	
	Settings :	When the target speed is reached, DO (TSPD) is enabled. It means when the motor speed in forward / reverse direction is higher than the setting value, the target speed is reached and enables DO.	
			Related Section: Table 8.2

P1-40 ▲	VCM	Maximum Output of Analog Speed Command	Address: 0150H 0151H
	Operational Interface :	Panel / Software	Communication
	Default :	Same as the rated speed of each model	
	Control Mode :	S / T	
	Unit :	r/min	
	Range :	0 ~ 5000	
	Data Size :	16-bit	
	Format :	Decimal	
	Settings :	Maximum Speed of Analog Speed Command: In speed mode, the analog speed command inputs the swing speed setting of the max. voltage (10V). For example, if the setting is 3000, when the external voltage input is 10V, it means the speed control command is 3000r/min. If the external voltage input is 5V, then the speed control command is 1500r/min. Speed control command = input voltage value x setting value / 10	
			Related Section: 6.3.4



In position or torque mode, analog speed limit inputs the swing speed limit setting of the max. voltage (10V).

$$\text{Speed limit command} = \text{input voltage value} \times \text{setting value} / 10$$

<b>P1-41▲</b>	<b>TCM</b>	<b>Maximum Output of Analog Torque Speed</b>	<b>Address: 0152H 0153H</b>
	Operational Interface :	Panel / Software	Communication
	Default :	100	
	Control Mode :	ALL	
	Unit :	%	
	Range :	0 ~ 1000	
	Data Size :	16-bit	
	Format :	Decimal	

Related Section:  
6.4.4

Settings : Maximum Output of Analog Torque Speed:

In torque mode, the analog torque command inputs the torque setting of the max. voltage (10V). When the default setting is 100, if the external voltage inputs 10V, it means the torque control command is 100% rated torque. If the external voltage inputs 5V, then the torque control command is 50% rated torque.

$$\text{Torque control command} = \text{input voltage value} \times \text{setting value} / 10 (\%)$$

In speed, PT and PR mode, the analog torque limit inputs the torque limit setting of the max. voltage (10V).

$$\text{Torque limit command} = \text{input voltage value} \times \text{setting value} / 10 (\%)$$

<b>P1-42</b>	<b>MBT1</b>	<b>Enable Delay Time of Brake</b>	<b>Address: 0154H 0155H</b>
	Operational Interface :	Panel / Software	Communication
	Default :	0	
	Control Mode :	ALL	
	Unit :	ms	
	Range :	0 ~ 1000	
	Data Size :	16-bit	
	Format :	Decimal	

Related Section:  
6.5.5

Settings : Set the delay time from servo ON to activate the signal of mechanical brake (BRKR).

<b>P1-43</b>	<b>MBT2</b>	<b>Disable Delay Time of Brake</b>	<b>Address: 0156H 0157H</b>
	Operational Interface :	Panel / Software	Communication
	Default :	0	
	Control Mode :	ALL	
	Unit :	ms	
	Range :	-1000 ~ 1000	
	Data Size :	16-bit	
	Format :	Decimal	

Related Section: 6.5.5

Settings : Set the delay time from servo OFF to switch off the signal of brake (BRKR).

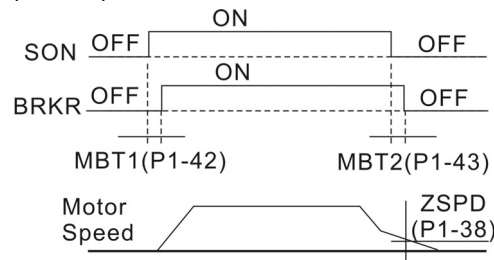

- NOTE**
- 1) If the delay time of P1-43 has not finished yet and the motor speed is slower than P1-38, the signal of brake (BRKR) will be disabled.
  - 2) If the delay time of P1-43 is up and the motor speed is higher than P1-38, the signal of brake (BRKR) will be disabled.
  - 3) When Servo OFF due to Alarm (except AL022) or emergency, the setting of P1-43 is equivalent to 0 if P1-43 is set to a negative value.

<b>P1-44▲</b>	<b>GR1</b>	<b>Gear Ratio (Numerator) (N1)</b>	<b>Address: 0158H 0159H</b>
	Operational Interface :	Panel / Software	Communication
	Default :	1	
	Control Mode :	PT / PR	
	Unit :	Pulse	
	Range :	1 ~ (2 <sup>29</sup> -1)	

Related Section: 6.2.5

Data Size :	32-bit
Format :	Decimal

Settings : Please refer to P2-60~P2-62 for the setting of multiple gear ratio (numerator).



**NOTE**

1. In PT mode, the setting value can be changed when Servo ON.
2. In PR mode, the setting value can be changed when Servo OFF.

<b>P1-45</b>	<b>GR2</b>	<b>Gear Ratio (Denominator) (M)</b>	<b>Address: 015AH 015BH</b>
--------------	------------	-------------------------------------	---------------------------------

Operational Interface :	Panel / Software	Communication	Related Section: 6.2.5
Default :	1		
Control Mode :	PT / PR		
Unit :	Pulse		
Range :	1 ~ (2 <sup>31</sup> -1)		
Data Size :	32-bit		
Format :	Decimal		

Settings : If the setting is wrong, the servo motor will easily have sudden unintended acceleration.

Please follow the rules for setting:

The setting of pulse input:

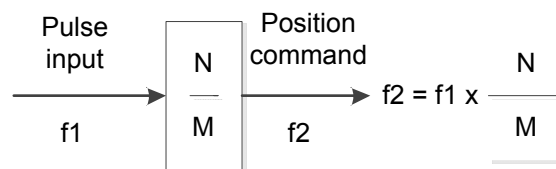

Range of command pulse input:  $1 / 50 < N_x / M < 25600$



**NOTE**

- 1) The setting value cannot be changed when Servo ON neither in PT nor in PR mode.

<b>P1-46 ▲</b>	<b>GR3</b>	<b>Pulse Number of Encoder Output</b>	<b>Address: 015CH 015DH</b>
----------------	------------	---------------------------------------	---------------------------------

Operational Interface :	Panel / Software	Communication	Related Section: -
Default :	2500		
Control Mode :	ALL		
Unit :	Pulse		

Range :	20 ~ 320000
Data Size :	32-bit
Format :	Decimal

Settings : The number of single-phase pulse output per revolution.



**NOTE** The following circumstances might exceed the max. allowable input pulse frequency and occurs AL018:

1. Abnormal encoder
2. The motor speed is faster than the setting of P1-76.
3.  $\frac{\text{Motor Speed}}{60} \times P1-46 \times 4 > 19.8 \times 10^6$

P1-47	SPOK	Speed Reached (DO : SP_OK) Range	Address: 015EH 015FH
Operational Interface :	Panel / Software	Communication	Related Section: -
Default :	10	100	
Control Mode :	S / Sz	S / Sz	
Unit :	r/min	0.1 r/min	
Range :	0 ~ 300	0 ~ 3000	
Data Size :	16-bit	16-bit	
Format :	Decimal	Decimal	

Settings : When the deviation between speed command and motor feedback speed is smaller than this parameter, then the digital output DO.SP\_OK (DO code is 0x19) is ON.

Block diagram:

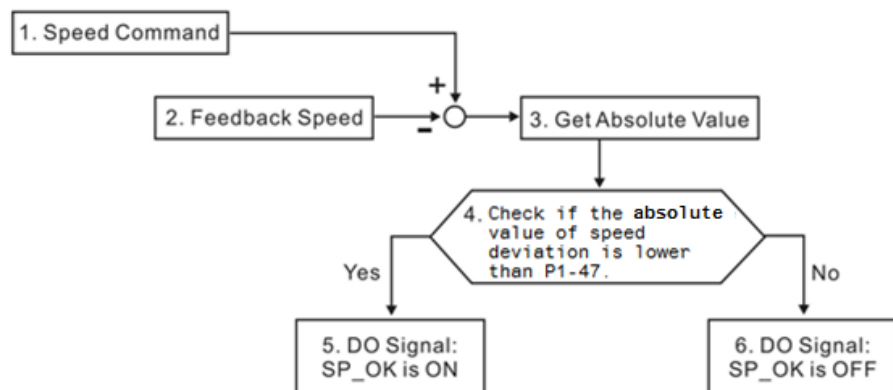

1. Speed command: It is the command issued by the user (without acceleration / deceleration), not the one of front end speed circuit.  
Source: Analog voltage and register
2. Feedback speed: The actual speed of the motor and have gone through the filter.
3. Obtain the absolute value.
4. DO.SP\_OK will be ON when the absolute value of speed error is smaller than P1-47, or it will be OFF. If P1-47 is 0, DO.SP\_OK is always OFF.

<b>P1-48</b>	<b>MCOK</b>	<b>Operation Selection of Motion Reached (DO.MC_OK)</b>	<b>Address: 0160H 0161H</b>
	Operational Interface :	Panel / Software      Communication	Related Section: -
	Default :	0x0000	
	Control Mode :	PR	
	Unit :	-	
	Range :	0x0000 ~ 0x0011	
	Data Size :	16-bit	
	Format :	Hexadecimal	

Settings : Control selection of digital output DO.MC\_OK (DO code is 0x17).  
 (It will be available after firmware version V1.003 sub08)  
 The format of this parameter: 00YX  
 X = 0: It will not remain the digital output status  
       1: It will remain the digital output status  
 Y = 0: AL.380 (position deviation) is not working  
       1: AL.380 (position deviation) is working

Block diagram:

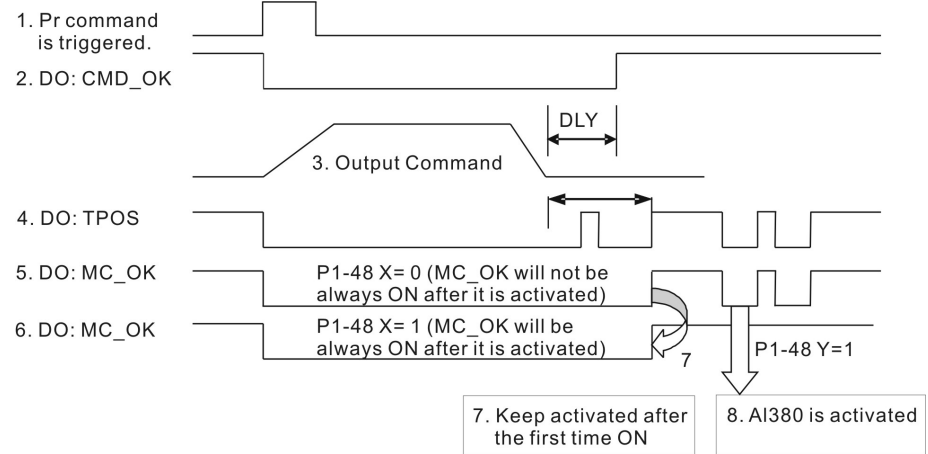

Description:

1. Command triggered: It means the new PR command is effective. Position command starts to output and clear signal 2, 4, 5, 6 at the same time.
2. CMD\_OK: It means the position command is completely outputted and can set the delay time (DLY).
3. Command output: Output the profile of position command according to the setting acceleration / deceleration.
4. TPOS: It means the position error of the servo drive is smaller than the value of P1-54.
5. MC\_OK: It means the position command is completely outputted and the position error of the servo drive is smaller than P1-54.
6. MC\_OK (remains the digital output status): It is the same as 5. However, once this DO is ON, its status will be remained regardless signal 4 is OFF or not.
7. The output profile is determined by parameter P1-48.X.
8. Position Deviation: When number 7 happens, if 4 (or 5) is OFF, it means the position is deviated and AL380 can be triggered. Set this alarm via parameter P1-48.Y.

P1-49	SPOKWT	Accumulative Time of Speed Reached	Address: 0162H 0163H
Operational Interface :	Panel / Software	Communication	Related Section: Table 8.2
Default :	0		
Control Mode :	S/Sz		
Unit :	ms		
Range :	0 ~ 65535		
Data Size :	16-bit		

Format : DEC

Settings : In speed mode, when the deviation value between speed command and motor feedback speed is smaller than the range set by P1-47 and reaches the time set by P1-79, DO.SP\_OK will be On. If the deviation value exceeds the range set by P1-47, it has to reclock the time.

**P1-50 ~ P1-51** Reserved

**P1-52** RES1 Regenerative Resistor Value Address: 0168H 0169H

Operational Interface :	Panel / Software	Communication	Related Section: 2.7
Default :	Determined by the model. Please refer to the following table.		
Control Mode :	ALL		
Unit :	Ohm		
Range :	220V		
	Model	Setting Range	
	400W (included) or below	30 ~ 750	
	750W ~ 1.5kW	20 ~ 750	
	2kW ~ 4.5kW	10 ~ 750	
	5.5 W	8 ~ 750	
	7.5kW	5 ~ 750	
	11kW	8 ~ 750	
	15 kW	5 ~ 750	
	400V		
	Model	Setting Range	
	750W ~ 1.5kW	60 ~ 750	
	1.5kW ~ 2kW	40 ~ 750	
	3 W	30 ~ 750	
	4.5kW ~ 5.5kW	20 ~ 750	
	7.5kW	15 ~ 750	
Data Size :	16-bit		
Format :	Decimal		

Settings : 220V:

Model	Default
1.5 kW (included) or below	40Ω
2 kW ~ 4.5 kW (included)	20Ω
5.5 kW	15Ω
7.5 kW	15Ω

400V:

Model	Default
750W ~ 7.5kW	80Ω

Please refer to the description of P1-53 for the setting value when connecting regenerative resistor with different method.

<b>P1-53</b>	<b>RES2</b>	<b>Regenerative Resistor Capacity</b>	<b>Address: 016AH 016BH</b>
--------------	-------------	---------------------------------------	---------------------------------

Operational Interface : Panel / Software      Communication      Related Section: 2.7

Default : Determined by the model. Please refer to the following table.

Control Mode : ALL

Unit : Watt

Range : 0 ~ 6000  
(for 11kW, 15kW, the setting range is from 0 to 15000)

Data Size : 16-bit

Format : Decimal

Settings : 220V

Model	Default
200W (included) or below	0W
400W	40W
750W ~ 1.5kW	60W
2 kW ~ 4.5 kW (included)	100W
5.5 kW	0W
7.5 kW	0W

400V

Model	Default
750W ~ 1.5kW	100W
2 kW ~ 4.5 kW	0W



Following describes the setting value when connecting regenerative resistor with different method:

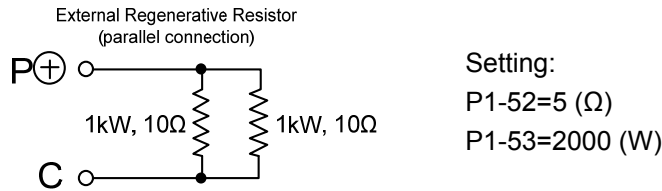
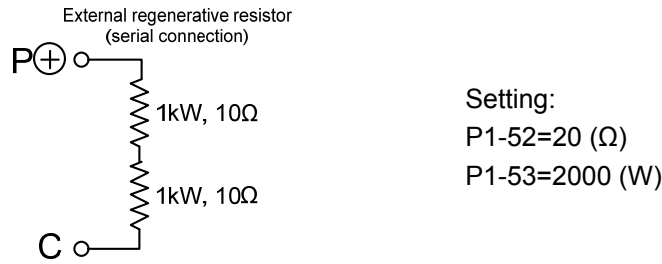
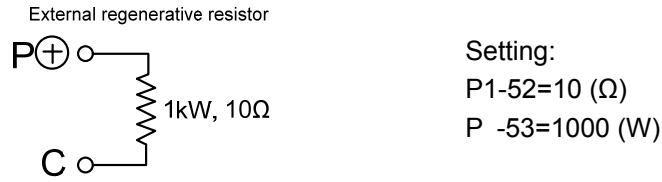

P1-54	PER	Position Completed Range	Address: 016CH 016DH
Operational Interface :	Panel / Software	Communication	Related Section: Table 8.2
Default :	12800		
Control Mode :	PT / PR		
Unit :	Pulse		
Range :	0 ~ 1280000		
Data Size :	32-bit		
Format :	Decimal		

Settings : In position mode (PT), if the deviation pulse number is smaller than the setting range (the setting value of parameter P1-54), DO.TPOS is ON.  
In position register (PR) mode, if the deviation between the target position and the actual motor position is smaller than the setting range (the setting value of parameter P1-54), DO.TPOS is ON.

P1-55	MSPD	Maximum Speed Limit	Address: 016EH 016FH
Operational Interface :		Panel / Software	Communication
Default :		Same as the rated speed of each model	
Control Mode :		ALL	
Unit :		r/min	
Range :		0 ~ max.speed	
Data Size :		16-bit	
Format :		Decimal	
Settings : The default of the max. speed of servo motor is set to the rated speed.			

P1-56	OVW	Output Overload Warning Level	Address: 0170H 0171H
Operational Interface :		Panel / Software	Communication
Default :		120	
Control Mode :		ALL	
Unit :		%	
Range :		0 ~ 120	
Data Size :		16-bit	
Format :		Decimal	
Settings : The setting value is 0 ~ 100, if the servo motor continuously outputs the load and is higher than the setting proportion (P1-56), the early warning for overload (DO is set to 10, OLW) will occur. If the setting value is over 100, it will disable this function.			

P1-57	CRSHA	Motor Crash Protection (torque percentage)	Address: 0172H 0173H
Operational Interface :		Panel / Software	Communication
Default :		0	
Control Mode :		ALL	

Unit :	%
Range :	0 ~ 300
Data Size :	16-bit
Format :	Decimal

Settings : Setup protection level (for the percentage of rated torque, set the value to 0 means to disable the function, set the value to 1 or number above means to enable the function)

<b>P1-58</b>	<b>CRSHT</b>	<b>Motor Crash Protection Time</b>	<b>Address: 0174H 0175H</b>
--------------	--------------	------------------------------------	---------------------------------

Operational Interface :	Panel / Software	Communication	Related Section: -
Default :	1		
Control Mode :	ALL		
Unit :	ms		
Range :	0 ~ 1000		
Data Size :	16-bit		
Format :	Decimal		

Settings : Setup the protection time:  
When it reaches the level, AL.030 occurs after exceeding the protection time.



**NOTE** This function is only suitable for non-contactable application, such as electric discharge machines. (Please setup P1-37 correctly).

<b>P1-59</b>	<b>MFLT</b>	<b>Analog Speed Command</b>	<b>Address: 0176H 0177H</b>
--------------	-------------	-----------------------------	---------------------------------

Operational Interface :	Panel / Software	Communication	Related Section: -
Default :	0.0	0	
Control Mode :	S		
Unit :	1 ms	0.1 ms	
Range :	0.0 ~ 4.0	0 ~ 40	
Data Size :	16-bit		
Format :	One decimal	DEC	

Example :	1.5 = 1.5 ms	15 = 1.5 ms
-----------	--------------	-------------

Settings : (Moving Filter)  
0: Disabled

P1-06 is low-pass filter and P1-59 is moving filter. The difference between both is that moving filter can smooth the command in the beginning and end of the step command; while the low-pass filter brings better smooth effect to command end.

Therefore, it is suggested that if the speed loop receives the command from the controller for forming the position control loop, then low-pass filter can be used. If it is only for the speed control, then it should use Moving Filter for better smoothing.

Original step analog speed command

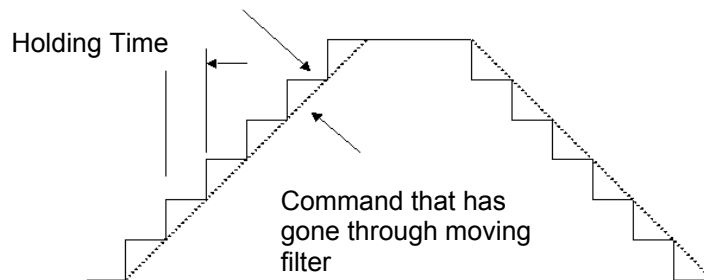

<b>P1-60 ~ P1-61</b>	<b>Reserved</b>
----------------------	-----------------

<b>P1-62</b>	<b>FRCL Friction Compensation</b>	<b>Address: 017CH 017DH</b>
--------------	-----------------------------------	---------------------------------

Operational Interface :	Panel / Software	Communication	Related Section: -
Default :	0		
Control Mode :	PT / PR / S		
Unit :	%		
Range :	0 ~ 100		
Data Size :	16-bit		
Format :	Decimal		

Settings : The level of friction compensation (the percentage of rated torque. Set the value to 0 means to disable the function; set the value to 1 or number above means to enable it.)

<b>P1-63</b>	<b>FRCT</b>	<b>Friction Compensation</b>	<b>Address: 017EH 017FH</b>
	Operational Interface :	Panel / Software	Communication
	Default :	0	
	Control Mode :	PT / PR / S	
	Unit :	ms	
	Range :	0 ~ 1000	
	Data Size :	16-bit	
	Format :	Decimal	

Settings : Setup smoothing constant of friction compensation.

<b>P1-64</b>	<b>PCCT</b>	<b>Analog Position Command: Activation Control</b>	<b>Address: 0180H 0181H</b>
	Operational Interface :	Panel/Software	Communication
	Default :	0x00	
	Control Mode :	PT	
	Unit :	--	
	Range :	0 x00~ 0x11	
	Data Size :	32-bit	
	Format :	Hexadecimal	

Settings :

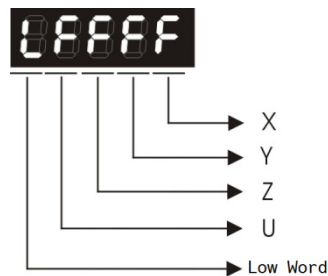

X:

- 0: Disable the function of position command which is issued by analog
- 1: Enable the function of position command which is issued by analog

Y: Initial position setting

0: After servo on, the motor will regard the current position as the position when the voltage is 0. Then the motor will operate to the position according to the command issued by analog input.

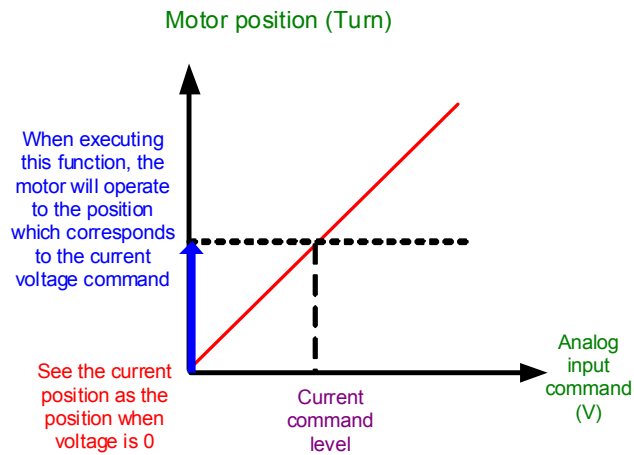

1: After SERVO ON, if the command level is not changed, the motor will not operate. The position the motor stops is the position that corresponds to the current command level.

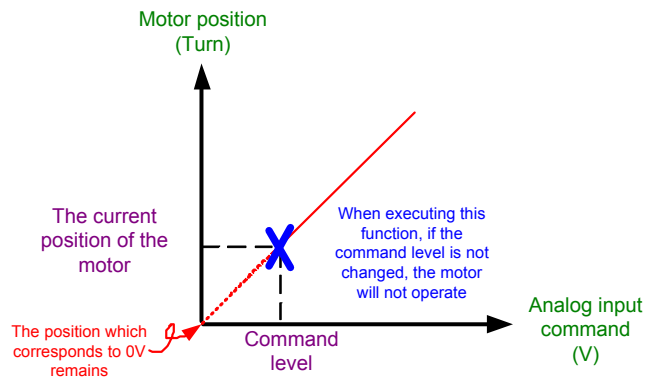

Z: Reserved  
U: Reserved



**NOTE** Version after firmware v1.031 sub8 supports this function.

P1-65	Smooth Constant of Analog Position Command	Address: 0182H 0183H
Operational Interface :	Panel/Software      Communication	Related Section: N/A
Default :	1	
Control Mode :	PT	
Unit :	10 ms	

Range :	1 ~ 1000
Data Size :	16-bit
Format :	Decimal

Settings : The smooth constant of analog position command is only effective to analog position command.

<b>P1-66</b>	<b>PCM</b>	<b>Max. Rotation Number of Analog Position Command</b>	<b>Address: 0184H 0185H</b>
--------------	------------	--	---------------------------------

Operational Interface :	Panel / Software	Communication	Related Section: -
Default :	1.0	10	
Control Mode :	PT		
Unit :	1 cycle	0.1 cycle	
Range :	0.0 ~ 200.0	0 ~ 2000	
Data Size :	16-bit		
Format :	One decimal	DEC	
Example :	1.5 = 1.5 cycles	15 = 1.5 cycles	

Settings : It is the rotation number setting when analog speed command inputs the max. voltage (10V). If it is set to 30 and the external voltage inputs 10V, it means the position command is +3 cycles. 5V means the speed control command is 1.5 cycles. -10V means the position command is -3 cycles.

Position control command = Input voltage value x Setting value / 10



**NOTE** It will be available after firmware version v1.031 sub8.

<b>P1-67</b>	<b>Reserved</b>
--------------	-----------------

<b>P1-68</b>	<b>PFLT2</b>	<b>Position Command Moving Filter</b>	<b>Address: 0188H 0189H</b>
--------------	--------------	---------------------------------------	---------------------------------

Operational Interface :	Panel / Software	Communication	Related Section: -
Default :	4		
Control Mode :	PT / PR		
Unit :	ms		
Range :	0 ~ 100		

Data Size :	16-bit
Format :	Decimal

Settings : 0: Disabled  
 Moving Filter can activate smooth function in the beginning and the end of step command, but it will delay the command.

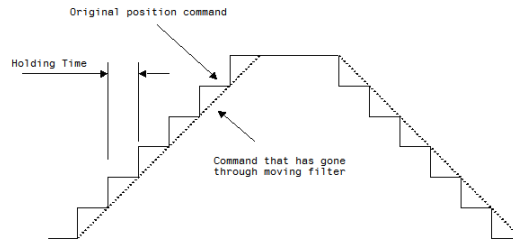

<b>P1-69 ~ P1-71</b>	<b>Reserved</b>
----------------------	-----------------

<b>P1-72</b>	<b>FRES</b>	<b>Resolution of Linear Scale for Full-closed Loop Control</b>	<b>Address: 0190H 0191H</b>
--------------	-------------	--	---------------------------------

Operational Interface :	Panel / Software	Communication	Related Section: -
-------------------------	------------------	---------------	--------------------

Default :	5000
-----------	------

Control Mode :	PT
----------------	----

Unit :	pulse / rev
--------	-------------

Range :	200 ~1280000
---------	--------------

Data Size :	32-bit
-------------	--------

Format :	Decimal
----------	---------

Settings : A/B pulse corresponded by full-closed loop when motor runs a cycle (after quadruple frequency)



<b>P1-73</b>	<b>FERR</b>	<b>Error Protection Range for Full-closed Loop Control</b>		<b>Address: 0192H 0193H</b>
	Operational Interface :	Panel / Software	Communication	Related Section: P2-34
	Default :	30000		
	Control Mode :	PT		
	Unit :	Pulse (based on the feedback of full-closed loop)		
	Range :	1 ~ (2 <sup>31</sup> -1)		
	Data Size :	32-bit		
	Format :	Decimal		

Settings : The protection is for excessive deviation between feedback position of linear scale and the encoder. When the deviation is excessive, it might result from the loose of connector or other mechanism problems.

<b>P1-74▲</b>	<b>FCON</b>	<b>Full-closed Loop Control of Linear Scale</b>		<b>Address: 0194H 0195H</b>
	Operational Interface :	Panel / Software	Communication	Related Section: P1-46
	Default :	1000h		
	Control Mode :	PT		
	Unit :	-		
	Range :	0000h ~ 0x4122		
	Data Size :	16-bit		
	Format :	Hexadecimal		

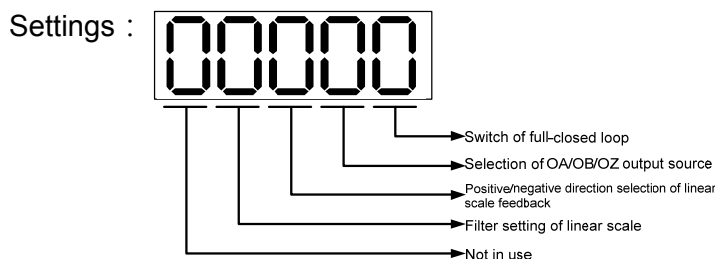

- Switch of full-closed loop control
  - 0: Function of full-closed loop is not used
  - 1: Function of full-closed loop is used
  - 2: Use the function of synchronous control
- Selection of OA/OB/OZ output source
  - 0: Motor encoder is the output source
  - 1: Encoder of linear scale is the output source
 Firmware version DSP V1.016 + CPLD 0.07(or the later version) will provide:
  - 2: Pulse command of CN1 is the output source
- Positive / negative direction selection of linear scale feedback:
  - 0: It is in positive direction when A phase leads B phase of linear scale
  - 1: It is in negative direction when B phase leads A phase of linear scale
- Filter setting of linear scale
  - 0: BYPASS
  - 1: 20Mhz
  - 2: 10Mhz
  - 3: 6.66Mhz
  - 4: 1.66Mhz
  - 5: 833K
  - 6: 416K

<b>P1-75</b>	<b>FELP</b>	<b>Low-pass Filter Time Constant of Full-closed Loop control</b>		<b>Address: 0196H 0197H</b>
	Operational Interface :	Panel / Software	Communication	Related Section: -
	Default :	100		
	Control Mode :	PT		
	Unit :	ms		
	Range :	0 ~ 1000		
	Data Size :	16-bit		
	Format :	Decimal		

Settings : When the stiffness of mechanical system between full- and half-closed loops is insufficient, users can setup the appropriate time constant to enhance the stability of the system.

Set the value to 0 to disable the function of low-pass filter (Bypass)

The stiffness of mechanical system ↑, the setting value of P1-75 ↓

The stiffness of mechanical system ↓, the setting value of P1-75 ↑

<b>P1-76</b>	<b>AMSPD</b>	<b>Maximum Rotation of Encoder Output Setting (OA, OB)</b>		<b>Address: 0198H 0199H</b>
	Operational Interface :	Panel / Software	Communication	Related Section: P1-46
	Default :	5500		
	Control Mode :	ALL		
	Unit :	r/min		
	Range :	0 ~ 6000		
	Data Size :	16-bit		
	Format :	Decimal		
Settings :	According to the real application, this parameter is set for the maximum speed and the servo drive will generate smooth function automatically for encoder output signals. When the value is set to 0, the function is disabled.			

<b>P1-77 ~ P1-80</b>	<b>Reserved</b>
--------------------------	-----------------

<b>P1-81</b>	<b>VCM2</b>	<b>Max. Speed of 2<sup>nd</sup> Analog Speed Command</b>		<b>Address: 01A2H 01A3H</b>
	Operational Interface :	Panel / Software	Communication	Related Section: P1-40
	Default :	Motor rated speed		
	Control Mode :	S/T		
	Unit :	rpm/10V		
	Range :	0 ~ 50000		
	Data Size :	32-bit		
	Format :	Decimal		
Settings :	Please refer to the description of P1-40.			

P1-82	VCMLPF	Filter Switching Time between P1-40 and P1-81	Address: 01A4H 01A5H
	Operational Interface :	Panel / Software	Communication
	Default :	0	
	Control Mode :	S	
	Unit :	msec	
	Range :	0 ~ 1000 (0: disable this function)	
	Data Size :	16-bit	
	Format :	Decimal	
	Settings :	0: Disabled	
			Related Section:

P1-83	VCMLPF	Abnormal Analog Input Voltage Level	Address: 01A6H 01A7H
	Operational Interface :	Panel/Software	Communication
	Default :	0	
	Control Mode :	S	
	Unit :	mV	
	Range :	0 ~ 12000 (0: disable this function)	
	Data Size :	16-bit	
	Format :	Decimal	
	Settings :	When analog input voltage is over 50ms, AL.042 will occur. The compared level for this parameter is the original analog input voltage which has not been added by an offset value via parameter P4-22, Analog Speed Input Offset.	
			Related Section:

P1-87	HMTQL	Torque Limit Setting	Address: 01A8H 01A9H
	Operational Interface :	Panel/Software	Communication
	Default :	1	
	Control Mode :	PR	
	Unit :	%	
	Range :	1~300	
	Data Size :	16-bit	
	Format :	Decimal	
	Settings : Torque limit setting in torque limit homing mode.		

P1-88	HMTQT	Torque Limit Time Setting	Address: 01AAH 01ABH
	Operational Interface :	Panel/Software	Communication
	Default :	2000	
	Control Mode :	PR	
	Unit :	ms	
	Range :	2~2000	
	Data Size :	16-bit	
	Format :	Decimal	
	Settings : Torque limit time setting in torque limit homing mode.		

## P2-xx Extension Parameters

P2-00	KPP	Position Loop Gain	Address: 0200H 0201H
	Operational Interface :	Panel / Software      Communication	Related Section: 6.2.8
	Default :	35	
	Control Mode :	PT / PR	
	Unit :	rad/s	
	Range :	0 ~ 2047	
	Data Size :	16-bit	
	Format :	Decimal	
	Settings :	When the value of position loop gain is increased, the position response can be enhanced and the position error can be reduced. If the value is set too big, it may easily cause vibration and noise.	

P2-01	PPR	Switching Rate of Position Loop Gain	Address: 0202H 0203H
	Operational Interface :	Panel / Software      Communication	Related Section: 6.2.8
	Default :	100	
	Control Mode :	PT / PR	
	Unit :	%	
	Range :	10 ~ 500	
	Data Size :	16-bit	
	Format :	Decimal	
	Settings :	Switch the changing rate of position loop gain according to the gain-switching condition.	

P2-02	PFG	Position Feed Forward Gain	Address: 0204H 0205H
Operational Interface :		Panel / Software	Communication
Default :		50	
Control Mode :		PT / PR	
Unit :		%	
Range :		0 ~ 100	
Data Size :		16-bit	
Format :		Decimal	
Settings :		<p>If the position command is changed smoothly, increasing the gain value can reduce the position error.</p> <p>If the position command is not changed smoothly, decreasing the gain value can tackle the problem of mechanical vibration.</p>	
Related Section: 6.2.8			

P2-03	PFF	Smooth Constant of Position Feed Forward Gain	Address: 0206H 0207H
Operational Interface :		Panel / Software	Communication
Default :		5	
Control Mode :		PT / PR	
Unit :		ms	
Range :		2 ~ 100	
Data Size :		16-bit	
Format :		Decimal	
Settings :		<p>If the position command is changed smoothly, decreasing the value can reduce the position error. If the position command is not changed smoothly, increasing the value can tackle the problem of mechanical vibration.</p>	
Related Section: -			

P2-04	KVP	Speed Loop Gain	Address: 0208H 0209H
Operational Interface :		Panel / Software	Communication
Default :		500	
Control Mode :		ALL	
Unit :		rad/s	
Range :		0 ~ 8191	
Data Size :		16-bit	
Format :		Decimal	
Settings : Increase the value of speed loop gain can enhance the speed response. However, if the value is set too big, it would easily cause resonance and noise.			

P2-05	SPR	Switching Rate of Speed Loop Gain	Address: 020AH 020BH
Operational Interface :		Panel / Software	Communication
Default :		100	
Control Mode :		ALL	
Unit :		%	
Range :		10 ~ 500	
Data Size :		16-bit	
Format :		Decimal	
Settings : Switch the changing rate of speed loop gain according to the gain switching condition.			



P2-06	KVI	Speed Integral Compensation	Address: 020CH 020DH
Operational Interface :		Panel / Software	Communication
Default :		100	
Control Mode :		ALL	
Unit :		rad/s	
Range :		0 ~ 1023	
Data Size :		16-bit	
Format :		Decimal	
Settings : Increasing the value of speed integral compensation can enhance speed response and diminish the deviation of speed control. However, if the value is set too big, it would easily cause resonance and noise.			

P2-07	KVF	Speed Feed Forward Gain	Address: 020EH 020FH
Operational Interface :		Panel / Software	Communication
Default :		0	
Control Mode :		ALL	
Unit :		%	
Range :		0 ~ 100	
Data Size :		16-bit	
Format :		Decimal	
Settings : When the speed control command runs smoothly, increasing the gain value can reduce the speed command error. If the command does not run smoothly, decreasing the gain value can reduce the mechanical vibration during operation.			

<b>P2-08</b>	<b>PCTL</b>	<b>Special Parameter Write-in</b>	<b>Address: 0210H 0211H</b>
	Operational Interface :	Panel / Software	Communication
	Default :	0	
	Control Mode :	ALL	
	Unit :	-	
	Range :	0 ~ 65535	
	Data Size :	16-bit	
	Format :	Decimal	

Related Section: -

Settings : Special parameter write-in:

Parameter code	Function
10	Reset the parameter (Apply to the power again after reset)
20	P4-10 is writable
22	P4-11~P4-21are writable
30,35	Save the data of COMPARE, CAPTURE, E-Cam
406	Enable forced DO mode
400	When forced DO mode is enabled, it can switch back to the normal DO mode.

**NOTE**

A2L does not support E-Cam function.

<b>P2-09</b>	<b>DRT</b>	<b>DI Debouncing Time</b>	<b>Address: 0212H 0213H</b>
	Operational Interface :	Panel / Software	Communication
	Default :	2	
	Control Mode :	ALL	
	Unit :	ms	
	Range :	0 ~ 20	
	Data Size :	16-bit	
	Format :	Decimal	

Related Section: -

Settings : When the environmental noise is big, increasing the setting value can enhance the control stability. However, if the value is set too big, the response time will be influenced.

<b>P2-10</b>	<b>DI1</b>	<b>DI1 Functional Planning</b>	<b>Address: 0214H 0215H</b>
--------------	------------	--------------------------------	---------------------------------

Operational Interface :	Panel / Software	Communication	Related Section: Table 8.1
Default :	101		
Control Mode :	ALL		
Unit :	-		
Range :	0 ~ 0x015F (the last two codes are DI code)		
Data Size :	16-bit		
Format :	Hexadecimal		

Settings :

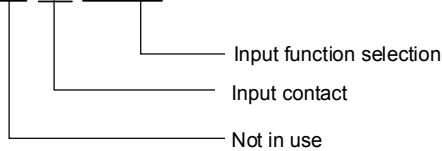

- Input function selection: Please refer to table 8.1
- Input contact: **a** or **b** contact
  - 0: Set the input contact as normally closed (**b** contact)
  - 1: Set the input contact as normally opened (**a** contact)

(P2-10 ~ P2-17) The setting value of function programmed

When parameters are modified, please re-start the servo drive to ensure it can work normally.

Note: Parameter P3-06 is used to set how digital inputs (DI) accepts commands, through external terminal or the communication which determined by P4-07.

<b>P2-11</b>	<b>DI2</b>	<b>DI2 Functional Planning</b>	<b>Address: 0216H 0217H</b>
--------------	------------	--------------------------------	---------------------------------

Operational Interface :	Panel / Software	Communication	Related Section: Table 8.1
Default :	104		
Control Mode :	ALL		
Unit :	-		
Range :	0 ~ 0x015F (the last two codes are DI code)		
Data Size :	16-bit		

Format : Hexadecimal

Settings : Please refer to the description of P2-10

<b>P2-12</b>	<b>DI3</b>	<b>DI3 Functional Planning</b>	<b>Address: 0218H 0219H</b>
	Operational Interface :	Panel / Software	Communication
	Default :	116	
	Control Mode :	ALL	
	Unit :	-	
	Range :	0 ~ 0x015F (the last two codes are DI code)	
	Data Size :	16-bit	
	Format :	Hexadecimal	

Related Section:  
Table 8.1

Settings : Please refer to the description of P2-10

<b>P2-13</b>	<b>DI4</b>	<b>DI4 Functional Planning</b>	<b>Address: 021AH 021BH</b>
	Operational Interface :	Panel / Software	Communication
	Default :	117	
	Control Mode :	ALL	
	Unit :	-	
	Range :	0 ~ 0x015F (the last two codes are DI code)	
	Data Size :	16-bit	
	Format :	Hexadecimal	

Related Section:  
Table 8.1

Settings : Please refer to the description of P2-10

P2-14	DI5	DI5 Functional Planning	Address: 021CH 021DH
	Operational Interface :	Panel / Software      Communication	Related Section: Table 8.1
	Default :	102	
	Control Mode :	ALL	
	Unit :	-	
	Range :	0 ~ 0x015F (the last two codes are DI code)	
	Data Size :	16-bit	
	Format :	Hexadecimal	
	Settings :	Please refer to the description of P2-10	

P2-15	DI6	DI6 Functional Planning	Address: 021EH 021FH
	Operational Interface :	Panel / Software      Communication	Related Section: Table 8.1
	Default :	22	
	Control Mode :	ALL	
	Unit :	-	
	Range :	0 ~ 0x015F (the last two codes are DI code)	
	Data Size :	16-bit	
	Format :	Hexadecimal	
	Settings :	Please refer to the description of P2-10	

P2-16	DI7	DI7 Functional Planning	Address: 0220H 0221H
	Operational Interface :	Panel / Software      Communication	Related Section: Table 8.1
	Default :	23	
	Control Mode :	ALL	
	Unit :	-	
	Range :	0 ~ 0x015F (the last two codes are DI code)	

Data Size :	16-bit
Format :	Hexadecimal

Settings : Please refer to the description of P2-10

<b>P2-17</b>	<b>DI8</b>	<b>DI8 Functional Planning</b>	<b>Address: 0222H 0223H</b>
--------------	------------	--------------------------------	---------------------------------

Operational Interface :	Panel / Software	Communication	Related Section: Table 8.1
Default :	21		
Control Mode :	ALL		
Unit :	-		
Range :	0 ~ 0x015F (the last two codes are DI code)		
Data Size :	16-bit		
Format :	Hexadecimal		

Settings : Please refer to the description of P2-10

<b>P2-18</b>	<b>DO1</b>	<b>DO1 Functional Planning</b>	<b>Address: 0224H 0225H</b>
--------------	------------	--------------------------------	---------------------------------

Operational Interface :	Panel / Software	Communication	Related Section: Table 8.2
Default :	101		
Control Mode :	ALL		
Unit :	-		
Range :	0 ~ 0x013F (the last two codes are DO code)		
Data Size :	16-bit		
Format :	Hexadecimal		

Settings :

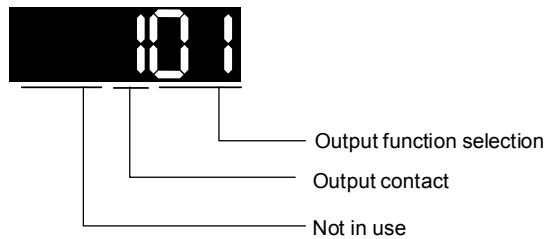

- Output function selection: Please refer to table 8.2
  - Output contact: **a** or **b** contact
    - 0: Set the output contact as normally closed (**b** contact)
    - 1: Set the output contact as normally opened (**a** contact)
- (P2-18 ~ P2-22) The setting value of function programmed
- When parameters are modified, please re-start the servo drive to ensure it can work normally.

P2-19	DO2	DO2 Functional Planning	Address: 0226H 0227H
	Operational Interface :	Panel / Software      Communication	Related Section: Table 8.2
	Default :	103	
	Control Mode :	ALL	
	Unit :	-	
	Range :	0 ~ 0x013F (the last two codes are DO code)	
	Data Size :	16-bit	
	Format :	Hexadecimal	
	Settings :	Please refer to the description of P2-18	

P2-20	DO3	DO3 Functional Planning	Address: 0228H 0229H
	Operational Interface :	Panel / Software      Communication	Related Section: Table 8.2
	Default :	109	
	Control Mode :	ALL	
	Unit :	-	
	Range :	0 ~ 0x013F (the last two codes are DO code)	
	Data Size :	16-bit	
	Format :	Hexadecimal	
	Settings :	Please refer to the description of P2-18	

P2-21	DO4	DO4 Functional Planning	Address: 022AH 022BH
Operational Interface :		Panel / Software	Communication
Default :		105	
Control Mode :		ALL	
Unit :		-	
Range :		0 ~ 0x013F (the last two codes are DO code)	
Data Size :		16-bit	
Format :		Hexadecimal	
Settings : Please refer to the description of P2-18			

P2-22	DO5	DO5 Functional Planning	Address: 022CH 022DH
Operational Interface :		Panel / Software	Communication
Default :		7	
Control Mode :		ALL	
Unit :		-	
Range :		0 ~ 0x013F (the last two codes are DO code)	
Data Size :		16-bit	
Format :		Hexadecimal	
Settings : Please refer to the description of P2-18			

P2-23	NCF1	Resonance Suppression (Notch filter) (1)	Address: 022EH 022FH
Operational Interface :		Panel / Software	Communication
Default :		1000	
Control Mode :		ALL	
Unit :		Hz	
Range :		50 ~ 1000	
Settings : Please refer to the description of P2-18			



Data Size :	16-bit
Format :	Decimal

Settings : The first setting value of resonance frequency. If P2-24 is set to 0, this function is disabled. P2-43 and P2-44 are the second Notch filter.

<b>P2-24</b>	<b>DPH1</b>	<b>Resonance Suppression (Notch filter) Attenuation Rate (1)</b>	<b>Address: 0230H 0231H</b>
--------------	-------------	--	---------------------------------

Operational Interface :	Panel / Software	Communication	Related Section: 6.3.7
-------------------------	------------------	---------------	---------------------------

Default :	0
-----------	---

Control Mode :	ALL
----------------	-----

Unit :	dB
--------	----

Range :	0 ~ 32 (0: disable the function of Notch filter)
---------	--

Data Size :	16-bit
-------------	--------

Format :	Decimal
----------	---------

Settings : The first resonance suppression (notch filter) attenuation rate. When this parameter is set to 0, the function of Notch filter is disabled.

**NOTE**

If the value of attenuation rate is set to 5, then, it would be -5dB.

<b>P2-25</b>	<b>NLP</b>	<b>Low-pass Filter of Resonance Suppression</b>	<b>Address: 0232H 0233H</b>
--------------	------------	---	---------------------------------

Operational Interface :	Panel / Software	Communication	Related Section: 6.3.7
-------------------------	------------------	---------------	---------------------------

Default :	0.2 (under 1kW) or 0.5 (other model)	2 (under 1kW) or 0.5 (other model)
-----------	---	---------------------------------------

Control Mode :	ALL
----------------	-----

Unit :	1 ms	0.1 ms
--------	------	--------

Range :	0.0 ~ 100.0	0 ~ 1000
---------	-------------	----------

Data Size :	16-bit
-------------	--------

Format :	One decimal	DEC
----------	-------------	-----

Example :	1.5 = 1.5 ms	15 = 1.5 ms
-----------	--------------	-------------

Settings : Set the low-pass filter of resonance suppression. When the value is set to 0, the function of low-pass filter is disabled.

P2-26	DST	Anti-interference Gain	Address: 0234H 0235H
Operational Interface :	Panel / Software	Communication	Related Section: -
Default :	0		
Control Mode :	ALL		
Unit :	1		
Range :	0 ~ 1023 (0: disable this function)		
Data Size :	16-bit		
Format :	Decimal		
Settings :	<p>Increasing the value of this parameter can increase the damping of speed loop. It is suggested to set P2-26 equals to the value of P2-06. If users desire to adjust P2-26, please follow the rules below.</p> <ol style="list-style-type: none"> <li>1. In speed mode, increase the value of this parameter can reduce speed overshoot.</li> <li>2. In position mode, decrease the value of this parameter can reduce position overshoot.</li> </ol>		

P2-27	GCC	Gain Switching and Switching Selection	Address: 0236H 0237H
Operational Interface :	Panel / Software	Communication	Related Section: -
Default :	0		
Control Mode :	ALL		
Unit :	-		
Range :	0x0000 ~ 0x0018		
Data Size :	16-bit		
Format :	Hexadecimal		

Settings :

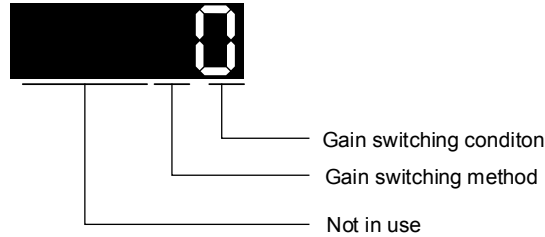

- Gain switching condition:
  - 0: Disable gain switching function.
  - 1: The signal of gain switching (GAINUP) is ON.
  - 2: In position control mode, the position error is bigger than the value of P2-29.
  - 3: The frequency of position command is bigger than the value of P2-29.
  - 4: When the speed of servo motor is faster than the value of P2-29.
  - 5: The signal of gain switching (GAINUP) is OFF.
  - 6: In position control mode, the position error is smaller than the value of P2-29.
  - 7: When the frequency of position command is smaller than the value of P2-29.
  - 8: When the speed of servo motor is slower than the value of P2-29.
- Gain switching method:
  - 0: Gain switching

1: Integrator switching, P -> PI

Setting Value	Control Mode P	Control Mode S	
0	P2-00 x 100% P2-04 x 100%	P2-04 x 100%	Before switching
	P2-00 x P2-01 P2-04 x P2-05	P2-04 x P2-05	After switching
1	P2-06 x 0% P2-26 x 0%		Before switching
	P2-06 x 100% P2-26 x 100%		After switching

P2-28	GUT	Gain Switching Time Constant	Address: 0238H 0239H
	Operational Interface :	Panel / Software	Communication
	Default :	10	
	Control Mode :	ALL	
	Unit :	10ms	
	Range :	0 ~ 1000	
			Related Section: -

Data Size :	16-bit
Format :	Decimal
Example :	15 = 150 ms

Settings : It is for switching the smooth gain. (0: disable this function)

<b>P2-29</b>	<b>GPE</b>	<b>Gain Switching</b>	<b>Address: 023AH 023BH</b>
--------------	------------	-----------------------	---------------------------------

Operational Interface :	Panel / Software	Communication	Related Section: -
-------------------------	------------------	---------------	--------------------

Default : 1280000

Control Mode : ALL

Unit : Pulse, Kpps, r/min

Range : 0 ~ 3840000

Data Size : 32-bit

Format : Decimal

Settings : The setting of gain switching (Pulse error, Kpps, r/min) is determined by the selection of gain switching (P2-27).

<b>P2-30</b>	<b>INH</b>	<b>Auxiliary Function</b>	<b>Address: 023CH 023DH</b>
--------------	------------	---------------------------	---------------------------------

Operational Interface :	Panel / Software	Communication	Related Section: -
-------------------------	------------------	---------------	--------------------

Default : 0

Control Mode : ALL

Unit : -

Range : -8 ~ +8

Data Size : 16-bit

Format : Decimal

- Settings :
- 0: Disable all functions described below
  - 1: Force to Servo On the software
  - 2~4: (reserved)
  - 5: This setting allows the written parameters not retain after power off. When the data is no need to save, it can avoid the parameters continuously writing into EEPROM and shortening the lifetime of EEPROM.  
Setting this parameter is a must when using communication control.
  - 6: In simulation mode (command simulation), the external Servo On signal cannot work and DSP Error (variable 0x6F) is regarded as 0. Parameter P0-01 only shows the external Error (positive/negative limit, emergency stop, etc)  
In this status, DO.SRDY is ON. Command is accepted in each mode and can be observed via scope software. However, the motor will not operate. The aim is to examine the command accuracy.
  - 7: (It will be available after firmware version V1.013)  
High-speed oscilloscope, disable Time-Out function (It is for PC software)
  - 8: (It will be available after firmware version V1.013)  
Back up all parameters (current value) and save in EEPROM. The value still exists when re-power on.  
The panel displays 'to.rom' during execution. (It can be executed when Servo ON.)
  - 1,-5,-6,-7: (It will be available after firmware version V1.013)  
Individually disable the function of 1,5,6,7
  - 2~-4, -8: (Reserved)



**NOTE** Please set the value to 0 in normal operation. The value returns to 0 automatically after re-power on.

P2-31	AUT1	Speed Loop Frequency Response Setting in Auto and Semi-auto Mode	Address: 023EH 023FH
Operational Interface :		Panel / Software	Related Section: 5.6 and 6.3.6
		Communication	
Default :		80	
Control Mode :		ALL	
Unit :		Hz	
Range :		1 ~ 1000	
Data Size :		16-bit	
Format :		Decimal	

Settings : 1~50Hz: Low stiffness, low response  
 51~250Hz: Medium stiffness, medium response  
 251~850Hz: High stiffness, high response  
 851~1000Hz: Extremely high stiffness, extremely high response

**NOTE**

- 1 ) According to the speed loop setting of P2-31, the servo drive sets the position loop response automatically.
- 2 ) The function is enabled via parameter P2-32. Please refer to Chapter 5.6 for corresponding bandwidth size of the setting value.

P2-32 ▲	AUT2	Tuning Mode Selection	Address: 0240H 0241H
	Operational Interface :	Panel / Software	Communication
	Default :	0	
	Control Mode :	ALL	
	Unit :	-	
	Range :	0 ~ 0x2	
	Data Size :	16-bit	
	Format :	Hexadecimal	
	Settings :	0: Manual Mode 1: Auto Mode (continuous adjustment) 2: Semi-auto Mode (non- continuous adjustment)	
			Related Section: 5.6 and 6.3.6

Relevant description of manual mode setting:

When P2-32 is set to 0, parameters related to gain control, such as P2-00, P2-04, P2-06, P2-25 and P2-26, all can be set by the user.

When switching mode from auto or semi-auto to manual, parameters about gain will be updated automatically.

Relevant description of auto mode setting:

Continue to estimate the system inertia, save the inertia ratio to P1-37 every 30 minutes automatically and refer to the stiffness and bandwidth setting of P2-31.

1. Set the system to manual mode 0 from auto 1 or semi-auto 2, the system will save the estimated inertia value to P1-37 automatically and set the corresponding parameters.
2. Set the system to auto mode 1 or semi-auto mode 2 from manual mode 0, please set P1-37 to the appropriate value.
3. Set the system to manual mode 0 from auto mode 1, P2-00, P2-04, P2-06, P2-25, P2-26 and P2-49 will be modified to the corresponding parameters of auto mode.
4. Set the system to manual mode 0 from semi-auto mode 2, P2-00, P2-04, P2-06, P2-25, P2-26 and P2-49 will be modified to the corresponding parameters of semi-auto mode.

Relevant description of semi-auto mode setting:

1. When the system inertia is stable, the value of P2-33 will be 1 and the system stops estimating. The inertia value will be saved to P1-37 automatically. When switching mode to semi-auto mode (from manual or auto mode), the system starts to estimate again.
2. When the system inertia is over the range, the value of P2-33 will be 0 and the system starts to estimate and adjust again.

P2-33 ▲	AUT3	Semi-auto Inertia Adjustment		Address: 0242H 0243H
Operational Interface :	Panel / Software	Communication	Related Section: -	
Default :	0			
Control Mode :	ALL			
Unit :	-			
Range :	0 ~ 0x1			
Data Size :	16-bit			
Format :	Hexadecimal			

Settings :

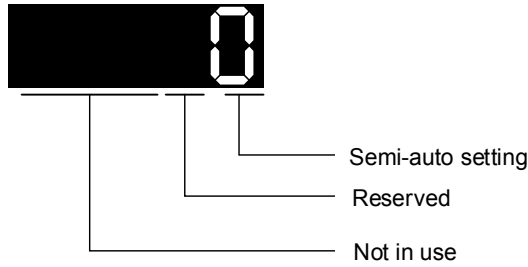

- Semi-auto Setting:
  - 1: It means the inertia estimation in semi-auto mode is completed. The inertia value can be accessed via P1-37.
  - 0: 1. When the display is 0, it means the inertia adjustment is not completed and is adjusting.  
2. When the setting is 0, it means the inertia adjustment is not completed and is adjusting.

<b>P2-34</b>	<b>SDEV</b>	<b>The Condition of Overspeed Warning</b>	<b>Address: 0244H 0245H</b>
	Operational Interface :	Panel / Software      Communication	Related Section: -
	Default :	5000	
	Control Mode :	S	
	Unit :	r/min	
	Range :	1 ~ 5000	
	Data Size :	16-bit	
	Format :	Decimal	
Settings :			

<b>P2-35</b>	<b>PDEV</b>	<b>Condition of Excessive Position Control Deviation Warning</b>	<b>Address: 0246H 0247H</b>
	Operational Interface :	Panel / Software      Communication	Related Section: -
	Default :	3840000	
	Control Mode :	PT / PR	
	Unit :	pulse	
	Range :	1 ~ 128000000	
	Data Size :	32-bit	
	Format :	Decimal	



Settings : The setting of excessive position control deviation warning in servo drive error display (P0-01)

<b>P2-36</b>	<b>EDI9</b>	<b>Extended EDI9 Functional Planning</b>	<b>Address: 0248H 0249H</b>
--------------	-------------	--	---------------------------------

Operational Interface :	Panel / Software	Communication	Related Section: Table 8.1
Default :	0		
Control Mode :	ALL		
Unit :	-		
Range :	0 ~ 0x015F (the last two codes are EDI code)		
Data Size :	16-bit		
Format :	Hexadecimal		

Settings :

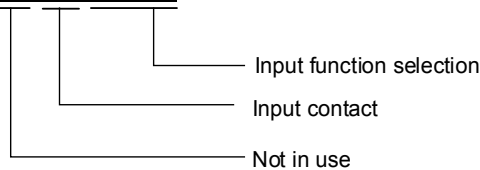

- Input function selection: Please refer to table 8.1
  - Input contact: **a** or **b** contact
    - 0: Set the input contact as normally closed (**b** contact)
    - 1: Set the input contact as normally opened (**a** contact)
- (P2-36 ~ P2-41) The setting value of function programmed
- When parameters are modified, please re-start the servo drive to ensure it can work normally.

<b>P2-37</b>	<b>EDI10</b>	<b>Extended EDI10 Functional Planning</b>	<b>Address: 024AH 024BH</b>
--------------	--------------	---	---------------------------------

Operational Interface :	Panel / Software	Communication	Related Section: Table 8.1
Default :	0		
Control Mode :	ALL		
Unit :	-		
Range :	0 ~ 0x015F (the last two codes are EDI code)		
Data Size :	16-bit		

Format : Hexadecimal

Settings : Please refer to the description of P2-36

<b>P2-38</b>	<b>EDI11</b>	<b>Extended EDI11 Functional Planning</b>	<b>Address: 024CH 024DH</b>
	Operational Interface :	Panel / Software	Communication
	Default :	0	
	Control Mode :	ALL	
	Unit :	-	
	Range :	0 ~ 0x015F (the last two codes are EDI code)	
	Data Size :	16-bit	
	Format :	Hexadecimal	
	Settings : Please refer to the description of P2-36		

<b>P2-39</b>	<b>EDI12</b>	<b>Extended EDI12 Functional Planning</b>	<b>Address: 024EH 024FH</b>
	Operational Interface :	Panel / Software	Communication
	Default :	-	
	Control Mode :	ALL	
	Unit :	-	
	Range :	0 ~ 0x015F (the last two codes are EDI code)	
	Data Size :	16-bit	
	Format :	Hexadecimal	
	Settings : Please refer to the description of P2-36		

P2-40	EDI13	Extended EDI13 Functional Planning	Address: 0250H 0251H
	Operational Interface :	Panel / Software      Communication	Related Section: Table 8.1
	Default :	-	
	Control Mode :	ALL	
	Unit :	-	
	Range :	0 ~ 0x015F (the last two codes are EDI code)	
	Data Size :	16-bit	
	Format :	Hexadecimal	
	Settings :	Please refer to the description of P2-36	

P2-41	EDI14	Extended EDI14 Functional Planning	Address: 0252H 0253H
	Operational Interface :	Panel / Software      Communication	Related Section: Table 8.1
	Default :	-	
	Control Mode :	ALL	
	Unit :	-	
	Range :	0 ~ 0x015F (the last two codes are EDI code)	
	Data Size :	16-bit	
	Format :	Hexadecimal	
	Settings :	Please refer to the description of P2-36	

P2-42	Reserved
-------	----------

P2-43	NCF2	Resonance Suppression (Notch filter) (2)	Address: 0256H 0257H
Operational Interface :		Panel / Software	Communication
Default :		1000	
Control Mode :		ALL	
Unit :		Hz	
Range :		50 ~ 2000	
Data Size :		16-bit	
Format :		Decimal	
Settings : The second setting value of resonance frequency. If P2-44 is set to 0, this function is disabled. P2-23 and P2-24 are the first Notch filter.			

P2-44	DPH2	Resonance Suppression (Notch filter) Attenuation Rate (2)	Address: 0258H 0259H
Operational Interface :		Panel / Software	Communication
Default :		0	
Control Mode :		ALL	
Unit :		dB	
Range :		0 ~ 32 (0: disable Notch filter)	
Data Size :		16-bit	
Format :		Decimal	
Settings : The second resonance suppression (notch filter) attenuation rate. When this parameter is set to 0, the function of Notch filter is disabled.			

**NOTE**

If the value of attenuation rate is set to 5, then it would be -5dB.

P2-45	NCF3	Resonance Suppression (Notch filter) (3)	Address: 025AH 025BH
Operational Interface :		Panel / Software	Communication
Default :		1000	
Control Mode :		ALL	
Unit :		Hz	
Range :		50 ~ 2000	
Data Size :		16-bit	
Format :		Decimal	
Settings : The third group of mechanism resonance frequency setting value. If P2-46 is set to 0, this function will be disabled. P2-23 and P2-24 are the first group of resonance suppression (Notch filter).			

P2-46	DPH3	Resonance Suppression (Notch filter) Attenuation Rate (3)	Address: 025CH 025DH
Operational Interface :		Panel / Software	Communication
Default :		0	
Control Mode :		ALL	
Unit :		dB	
Range :		0 ~ 32	
Data Size :		16-bit	
Format :		Decimal	
Settings : The third group of resonance suppression (Notch filter) attenuation rate. Set the value to 0 to disable the function of Notch filter.			

P2-47	ANCF	Auto Resonance Suppression Mode Setting	Address: 025EH 025FH
Operational Interface :		Panel / Software	Communication
Default :		1	
Control Mode :		ALL	
Related Section: -			

Unit :	-
Range :	0 ~ 2
Data Size :	16-bit
Format :	Decimal

Settings : 0: The value of P2-43, P2-44 and P2-45, P2-46 will retain.  
 1: The value of P2-43, P2-44 and P2-45, P2-46 will retain after resonance suppression.  
 2: Continuous resonance suppression

Description of Auto Mode Setting:

When it is set to 1: Auto resonance, the value returns to 0 automatically and saves the point of resonance suppression when it is stable. If it is unstable, re-power on or set back to 1 for re-estimation again.

When it is set to 2: Continuous suppression automatically. When it is stable, the point of resonance suppression will be saved. If it is unstable, re-power on for re-estimation.

When switching to mode 0 from mode 2 or 1, the setting of P2-43, P2-44, P2-45 and P2-46 will be saved automatically.

<b>P2-48</b>	<b>ANCL</b>	<b>Resonance Suppression Detection Level</b>	<b>Address: 0260H 0261H</b>

Operational Interface :	Panel / Software	Communication	Related Section: -
-------------------------	------------------	---------------	--------------------

Default : 100

Control Mode : ALL

Unit : -

Range : 1 ~ 300%

Data Size : 16-bit

Format : Decimal

Settings : (The smaller the setting value is, the more sensitive the resonance will be.)

P2-48↑, resonance sensitiveness↓

P2-48↓, resonance sensitiveness↑

<b>P2-49</b>	<b>SJIT</b>	<b>Speed Detection Filter</b>	<b>Address: 0262H 0263H</b>
	Operational Interface :	Panel / Software	Communication
	Default :	0	
	Control Mode :	ALL	
	Unit :	-	
	Range :	0x00 ~ 0x1F	
	Data Size :	16-bit	
	Format :	Decimal	

Settings : The filter of speed estimation

Setting Value	Speed Estimation Bandwidth (Hz)
00	2500
01	2250
02	2100
03	2000
04	1800
05	1600
06	1500
Setting Value	Speed Estimation Bandwidth (Hz)
07	1400
08	1300
09	1200
0A	1100
0B	1000
0C	950
0D	900
0E	850
0F	800
10	750
11	700
12	650
13	600
14	550
15	500
16	450
17	400

18	350
19	300
1A	250
1B	200
1C	175
1D	150
1E	125
1F	100

<b>P2-50</b>	<b>DCLR</b>	<b>Pulse Clear Mode</b>	<b>Address: 0264H 0265H</b>
	Operational Interface :	Panel / Software	Communication
	Default :	0	
	Control Mode :	PT	
	Unit :	-	
	Range :	0x0 ~ 0x1	
	Data Size :	16-bit	
	Format :	Hexadecimal	
Settings :	Please refer to table 8.1 for digital input setting. When set digital input (DI) as CCLR, the function of pulse clear is effective. Clear the position error (It is applicable in PT, PR mode). If this DI is ON, the accumulative position error will be cleared to 0. 0: The triggering method of CCLR is rising-edge. 1: The triggering method of CCLR is level.		

<b>P2-51</b>	<b>Reserved</b>
--------------	-----------------

<b>P2-52 ▲</b>	<b>IDXS</b>	<b>Indexing Coordinates Scale</b>	<b>Address: 0268H 0269H</b>
	Operational Interface :	Panel/Software	Communication
	Default :	1000000000	
	Control Mode :	ALL	
Unit :	PUU		Related Section:



Range :	0 ~ 1000000000
Data Size :	32-bit
Format :	Decimal

Settings : This parameter is used to set the scale of the indexing coordinates, indexing command position and indexing feedback position. If the setting value is too small, it may cause the error of indexing coordinates.

Range of setting value of P2-52:

$$P2-52 > 1.05 \times \text{Max. Motor Speed (r/min)} \times \frac{1280000}{60000} \times \frac{P1-45}{P1-44}$$

$$> 22.4 \times \text{Max. Motor Speed (r/min)} \times \frac{P1-45}{P1-44}$$

<b>P2-53</b>	<b>KPI</b>	<b>Position Integral Compensation</b>	<b>Address: 026AH 026BH</b>
	Operational Interface :	Panel / Software      Communication	Related Section: 6.3.6
	Default :	0	
	Control Mode :	ALL	
	Unit :	rad/s	
	Range :	0 ~ 1023	
	Data Size :	16-bit	
	Format :	Decimal	

Settings : When increasing the value of position control integral, reducing the position steady-state error, it may easily cause position overshoot and noise if the value is set too big.

<b>P2-54</b>	<b>SVP</b>	<b>The Gain of Synchronous Speed Control</b>	<b>Address: 026CH 026DH</b>
	Operational Interface :	Panel / Software      Communication	Related Section: -
	Default :	0	
	Control Mode :	ALL	
	Unit :	Rad/s	
	Range :	0~8191	
	Data Size :	16-bit	
	Format :	Decimal	

Settings : When increasing the value of synchronous speed control, it can enhance the speed following of two motors. However, if the value is set too big, it may easily cause vibration and noise.

P2-55	SVI	Integral Compensation to Synchronous Speed	Address: 026EH 026FH
Operational Interface :		Panel / Software	Communication
Default :		0	
Control Mode :		ALL	
Unit :		Rad/s	
Range :		0~1023	
Data Size :		16-bit	
Format :		Decimal	

Related Section: -

Settings : When increasing integral compensation to synchronous speed, two motors speed following can be enhanced and the speed error between two motors can be reduced. However, if the value is set too big, it may easily cause vibration and noise.

P2-56	SPI	Integral Compensation to Synchronous Position	Address: 0270H 0271H
Operational Interface :		Panel / Software	Communication
Default :		0	
Control Mode :		ALL	
Unit :		Rad	
Range :		0~1023	
Data Size :		16-bit	
Format :		Decimal	

Related Section: -

Settings : When increasing integral compensation to synchronous position, two motors speed following can be enhanced and the speed error between two motors can be reduced. However, if the value is set too big, it may easily cause vibration and noise. It is suggested to set the value the same as P2-06.

P2-57	SBW	The Bandwidth of Synchronous Control	Address: 0272H 0273H
Operational Interface :		Panel / Software	Communication
Default :		0	
Control Mode :		ALL	
Unit :		Hz	
Range :		0~1023	
Data Size :		16-bit	
Format :		Decimal	
<p>Settings : If users do not know how to set P2-54~P2-56, setting the bandwidth of synchronous control value will do since the value will correspond to P2-54~P2-56. The bigger the bandwidth of synchronous control value is, the better the synchronous effect will be. When increasing the bandwidth of speed loop and synchronous control, pay special attention to the response of P2-25 which should be faster than the setting of the both bandwidth.</p>			

P2-58	SVL	Low-pass Filter of Synchronous Speed Error	Address: 0274H 0275H
Operational Interface :		Panel / Software	Communication
Default :		0	
Control Mode :		ALL	
Unit :		0.1ms	
Range :		0~1000	
Data Size :		16-bit	
Format :		Decimal	
Example :		15 = 1.5 ms	
<p>Settings : If the synchronous control is influenced by low resolution and causes noise (not a high-pitched but rough sound), low-pass filter can be used to solve this problem. Please note that bandwidth of the synchronous control should be set as large as possible and should larger than the bandwidth of speed-loop.</p>			

P2-59	Reserved
-------	----------

<b>P2-60</b>	<b>GR4</b>	<b>Gear Ratio (Numerator) (N2)</b>	<b>Address: 0278H 0279H</b>
--------------	------------	------------------------------------	---------------------------------

Operational Interface :	Panel / Software	Communication	Related Section: -
Default :	128		
Control Mode :	PT		
Unit :	pulse		
Range :	1 ~ (2 <sup>29</sup> -1)		
Data Size :	32-bit		
Format :	Decimal		

Settings : The numerator of electronic gear ratio can be selected via DI.GNUM0 and DI.GNUM1 (Please refer to table 8.1). If DI.GNUM0 and DI.GNUM1 are not set, P1-44 will automatically be the numerator of electronic gear ratio. Please switch GNUM0 and GNUM1 in stop status to avoid the mechanical vibration.

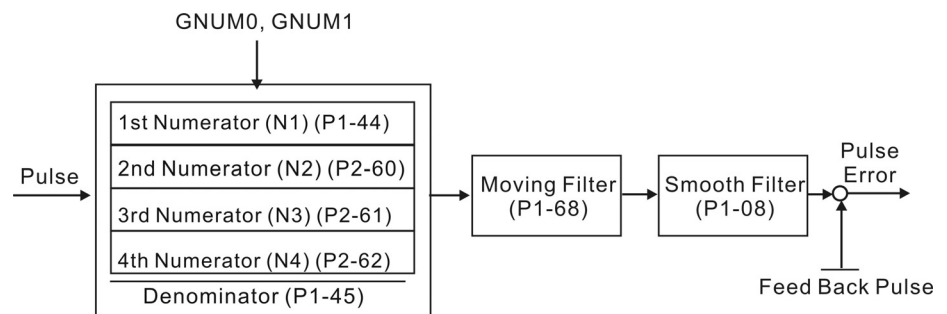

<b>P2-61</b>	<b>GR5</b>	<b>Gear Ratio (Numerator) (N3)</b>	<b>Address: 027AH 027BH</b>
--------------	------------	------------------------------------	---------------------------------

Operational Interface :	Panel / Software	Communication	Related Section: -
Default :	128		
Control Mode :	PT		
Unit :	pulse		
Range :	1 ~ (2 <sup>29</sup> -1)		
Data Size :	32-bit		
Format :	Decimal		

Settings : Please refer to the description of P2-60.

<b>P2-62</b>	<b>GR6</b>	<b>Gear Ratio (Numerator) (N4)</b>	<b>Address: 027CH 027DH</b>
	Operational Interface :	Panel / Software      Communication	Related Section: -
	Default :	128	
	Control Mode :	PT	
	Unit :	pulse	
	Range :	1 ~ (2 <sup>29</sup> -1)	
	Data Size :	32-bit	
	Format :	Decimal	
Settings : Please refer to the description of P2-60.			

<b>P2-63 ~ P2-64</b>	<b>Reserved</b>
----------------------	-----------------

<b>P2-65</b>	<b>GBIT</b>	<b>Special-bit Register</b>	<b>Address: 0282H 0283H</b>
	Operational Interface :	Panel / Software      Communication	Related Section: -
	Default :	0	
	Control Mode :	PT / PR / S	
	Unit :	-	
	Range :	0 ~ 0xFFFF	
	Data Size :	-	
	Format :	-	

Settings :

Bit7	Bit6	Bit5	Bit4	Bit3	Bit2	Bit1	Bit0
------	------	------	------	------	------	------	------

Bit15	Bit14	Bit13	Bit12	Bit11	Bit10	Bit9	Bit8
-------	-------	-------	-------	-------	-------	------	------

- Bit 3, 4, 5, 7 and Bit14: Reserved, please set to 0.
- Bit 0 ~ Bit1
  - Bit 0: SPD0/SPD1 speed trigger mode (0: level triggered; 1: rising-edge triggered)
  - Bit 1: TCM0/TCM1 torque trigger mode (0: level triggered; 1: rising-edge triggered)

When rising-edge is triggered, refer to the following for the setting of register command:

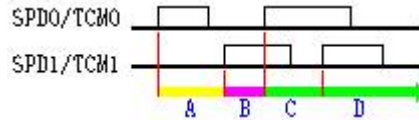

- A: Execute internal register command 1
- B: Execute internal register command 2
- C: Execute internal register command 3
- D: Execute internal register command 3

- Bit 2: IGBT software protection
  - 0: Enable the function of IGBT software protection
  - 1: Disable the function of IGBT software protection
- Bit 6: In PT mode, the switch of pulse error protection function (pulse frequency is over high)
  - 0: Normally use the function of pulse error protection
  - 1: Disable the function of pulse error protection
- Bit 8 : U, V, W wiring error protection
  - 1: Enable U, V, W wiring error protection
- Bit 9 : U, V, W wiring cut-off detection
  - 1: Enable U, V, W wiring cut-off detection
- Bit 10: DI.ZCLAMP function selection

When the following conditions are all established, the function of ZCLAMP is enabled.

Condition 1: speed mode

Condition 2: DI. ZCLAMP is on.

Condition 3: Motor speed is slower than the value of P1-38.

- 0: The command source is analog, ZCLAMP function will use the analog speed command without acceleration / deceleration processing to judge if this function should be enabled. The motor will be locked at the position where ZCLAMP conditions are established.

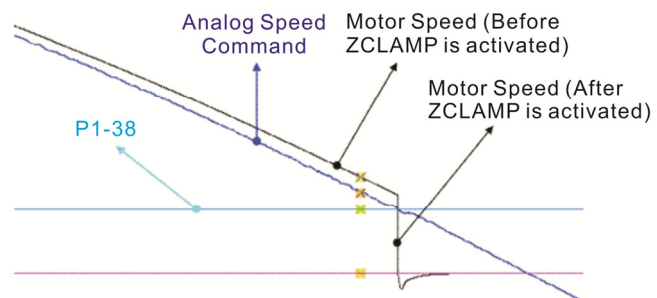

- 0: The command source is register. ZCLAMP function will use the register speed command with acceleration / deceleration processing to judge if this function is enabled. The motor will be locked at the position where ZCLAMP conditions are established.

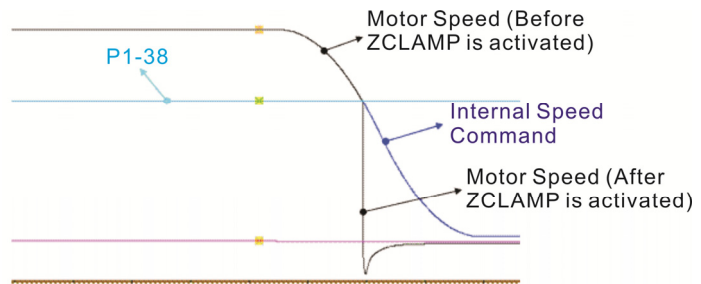

1: The command source is analog speed command. ZCLAMP function will use the analog speed command without acceleration / deceleration processing to judge if this function is enabled. When ZCLAMP conditions are established, the motor speed decelerates to 0 through S-curve. If not, the motor follow the analog speed command through S-curve.

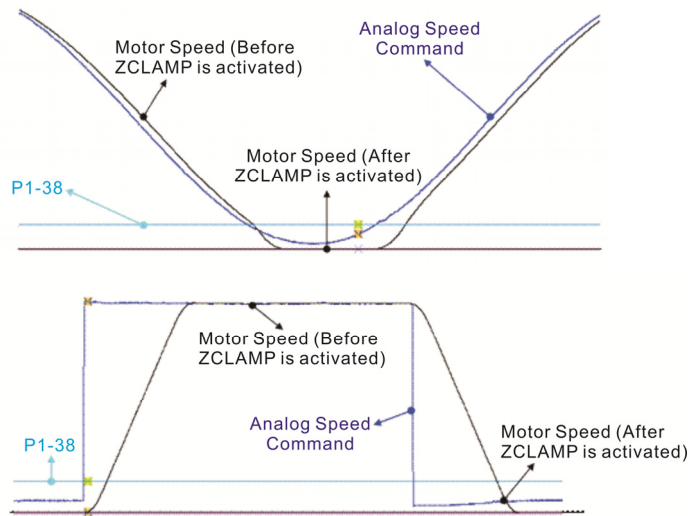

1: The command source is register. ZCLAMP function will use the register with acceleration / deceleration processing to judge if this function is enabled. When ZCLAMP conditions are established, the motor speed will be set to 0.

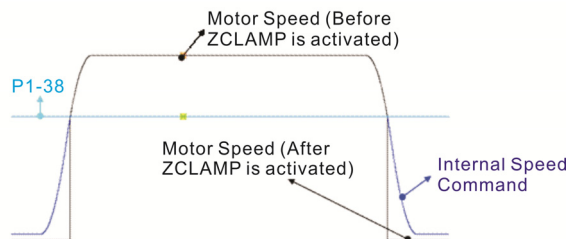

● Bit 11: Pulse inhibit function

0: Disable NL / PL pulse input inhibit function. In PT mode, the external position pulse command will be input into the servo drive in any condition.

1: Enable NL / PL pulse input inhibit function. In PT mode, if NL exists, the external NL pulse will be inhibited to input to the servo. PL pulse input will be accepted. In PT mode, if PL exists, the external PL pulse will be inhibited to input to the servo. NL pulse will be accepted.

Please note: In PT mode, if NL and PL both exist, both of them will be inhibited to input to the servo.

● Bit12: Lack phase detection

- 0: Enable lack phase (AL022) detection
- 1: Disable lack phase (AL022) detection
- Bit13: Encoder output error detection function
  - 0: Enable encoder output error (AL018) detection function
  - 1: Disable encoder output error (AL018) detection function
- Bit15: Friction compensation mode selection
  - 0: If the speed is slower than the value of P1-38, the compensation value remains.
  - 1: If the speed is slower than the value of P1-38, the compensation will become 0 according to the smoothing time of P1-63.

P2-66	GBIT2	Special-bit Register 2	Address: 0284H 0285H
Operational Interface :	Panel / Software	Communication	Related Section: -
Default :	0		
Control Mode :	PT / PR / S		
Unit :	-		
Range :	0 ~ 0x000F		
Data Size :	16-bit		
Format :	Hexadecimal		



Settings : Special-bit Register 2:

B7	B6	B5	B4	B3	B2	B1	B0
-	-	-	-	-	-	-	-

B0~B1: Reserved

B2: Cancel latch function of low-voltage error

0: Latch function of low-voltage error: the error will not be cleared automatically.

1: Cancel latch function of low-voltage error: the error will be cleared automatically.

B3: Reserved

B4: Cancel the detection of AL.044

0: AL.044 will occur

1: AL.044 will be ignored.

B5: Enable disconnection detection of linear scale (only when the full-closed loop control function is enabled)

0: AL.041 will be ignored

1: AL.041 will occur

B6~B8: Reserved

B9: When AL.003 occurs, switch on DO.ALM or DO.WARN

0: When AL.003 occurs, switch on DO.WARN.

1: When AL.003 occurs, switch on DO.ALM

B10~B15: Reserved.

<b>P2-67</b>	<b>JSL</b>	<b>The Stable Level of Inertia Estimation</b>		<b>Address: 0286H 0287H</b>
	Operational Interface :	Panel / Software	Communication	Related Section: -
	Default :	1.5	15	
	Control Mode :	ALL		
	Unit :	1times	0.1times	
	Range :	0 ~ 200.0	0 ~ 2000	
	Data Size :	16-bit		
	Format :	One decimal	Decimal	
	Example :	1.5 = 1.5 times	15 = 1.5 times	

Settings : In semi-auto mode, if the value of inertia estimation is smaller than P2-67 and the status remains for a while, the system will regard the inertia estimation as completed.

P2-68	TEP	Switch of Following Error Compensation	Address: 0288H 0289H
Operational Interface :		Panel / Software	Communication
Default :		0	
Control Mode :		ALL	
Unit :		-	
Range :		0x00000000 ~ 0x00002101	
Data Size :		16-bit	
Format :		Hexadecimal	

Related Section: -

Settings : X = 0: P1-36 > 1, following error compensation is disabled.

1: P1-36 > 1, following error compensation is enabled.

(The function is available after V1.036 sub00)

Y = 0: When E-CAM is engaged, JOG cannot work.

1: When E-CAM is engaged, JOG can work.

(This function is not available now.)

Z = 0: DI.STP is triggered by rising edge.

1: DI.STP is level triggered.

(The function is available after V1.042 sub00)

U = 0: unit is 0.1 rpm in speed mode

1: unit is 0.01 rpm in speed mode

2: unit is 0.05 rpm in speed mode

P2-69●	ABS	Absolute Encoder Setting	Address: 028AH 028BH
Operational Interface :		Panel / Software	Communication
Default :		0	
Control Mode :		ALL	
Unit :		N/A	
Range :		0x0000 ~ 0x0011	
Data Size :		16-bit	
Format :		Hexadecimal	

Related Section: N/A

Settings : Format: U Z Y X

X: Setup the operation mode

0: Incremental mode. Servo motor with absolute encoder can be

operated as incremental motor.

1: Absolute mode. (This setting is only available for the servo motor with absolute encoder. When an incremental servo motor is connected, AL069 will occur.)

Y: Setup the pulse command when absolute position is lost

0: When AL060 or AL06A occurs, it cannot accept pulse command

1: When AL060 or AL06A occurs, it can accept pulse command

Z: Function setting when index coordinates overflow

0: Index coordinates is lost when overflows

1: Index coordinates will not overflow, but absolute coordinates will not remain

U: Reserved



**NOTE** This parameter is effective only after the servo drive is re-powered on.

<b>P2-70</b>	<b>MRS</b>	<b>Read Data Format Selection</b>		<b>Address: 028CH 028DH</b>
	Operational Interface :	Panel / Software	Communication	Related Section: N/A
	Default :	0x0		
	Control Mode :	ALL		
	Unit :	N/A		
	Range :	0x00 ~ 0x07		
	Data Size :	16-bit		
	Format :	Hexadecimal		

Settings :

Bit7	Bit6	Bit5	Bit4	Bit3	Bit2	Bit1	Bit0
Bit15	Bit14	Bit13	Bit12	Bit11	Bit10	Bit9	Bit8

Bit 0: Data unit setting of digital input/output (DI/DO);

1: Pulse, 0: PUU

Bit 1: Communication data unit setting; 1: Pulse, 0: PUU

Bit 2: Overflow warning; 1: No overflow warning, 0: Overflow warning, AL.289 (PUU), AL.062 (pulse).

Bit 3 ~ Bit15: Reserved. Must be set to 0.

P2-71	CAP	Absolute Position Homing	Address: 028EH 028FH
Operational Interface :		Panel / Software	Communication
Default :		0x0	
Control Mode :		ALL	
Unit :		N/A	
Range :		0x0 ~ 0x1	
Data Size :		16-bit	
Format :		Hexadecimal	

Related Section: N/A

Settings : When P2-71 is set to 1, the current position will be set as home position. This function is the same as the digital input, ABSC. This function can be enabled only when parameter P2-08 is set to 271.

P2-72	Reserved
-------	----------

P2-73	ALOP	E-Cam Alignment - Operation Setting	Address: 0292H 0293H
Operational Interface :		Panel / Software	Communication
Default :		0x00000000	
Control Mode :		PR	
Unit :		N/A	
Range :		0x00000000 ~ 0x5F3F6F5F	
Data Size :		32-bit format = DCBA : UZYX	
Format :		Hexadecimal	

Related Section: N/A

Settings : (This function is available in firmware version V1.038 sub26 and later models)

YX: Range of filter (0 ~ 95%)

UZ: Max. allowable correction rate (0 ~ 100%)

BA: PR number (0 ~ 63)

DC: Masking range setting (0 ~ 95%)

YX: Range of filter (%)

When digital input, ALGN is triggered, E-Cam alignment function is enabled. The system will detect the current E-Cam position. When the error between current E-Cam position and the last alignment position is less than this setting range (%), filter function is enabled

and the system will average the errors before correction to avoid noise. If the error is bigger than filter threshold, the system will use the new position to do the correction.

YX	00	01 ~ 05F
Function	Disabled	Error   <= (1~YX) % : Enabled

\*Using filter will allow the alignment action to be more stable and reduce position error caused by digital input noise.

UZ: Max. Max. allowable correction rate (%)

When alignment correction is enabled, the limitation of max. correction rate (C) for each correction is defined as follows:

$$| C | \leq (P5-84/P5-83) \times P2-73 \text{ UZ } \%$$

\*When the alignment error is too big, to correct this error with one time may cause the motor vibration or overloading. Using this parameter will break the alignment correction into several smaller actions to smooth the correction action. But it may need more time to finish the alignment correction.

BA: PR number

After each alignment action is done, the shortage of pulse numbers of slave axis will be stored in this specified PR. Using this PR can compensate the slave position at appropriate timing.

\*If BA is set to 0, it will not store the shortage of pulse numbers to PR.

DC: Masking range setting (%)

When digital input, ALGN is triggered, no another alignment action is allowed before the increasing pulse numbers of master axis exceeds the masking distance (M). After the increasing pulse numbers of master axis is greater than the distance (M) masking, the next alignment action is allowed.

The masking distance (M) is defined as follows:

$$M \geq (P5-84/P5-83) \times P2-73 \text{ DC } \%$$

\*This masking function only allows increasing pulse input. This function will not work for decreasing pulse input.

<b>P2-74</b>	<b>ALDY</b>	<b>E-Cam Alignment - DI Delay Time Compensation</b>		<b>Address: 0294H 0295H</b>
	Operational Interface :	Panel / Software	Communication	Related Section: N/A
	Default :	0.000		
	Control Mode :	PR		
	Unit :	ms with fraction down to usec		
	Range :	-25.000 ~ +25.000, with 3 fraction digits		

Data Size : 16-bit

Format : Decimal

Settings : (This function is available in firmware version V1.038 sub26 and later models)

This parameter is used to set for the compensation of delay time from digital input.

**P2-75**

<b>ALTG</b>	<b>E-Cam Alignment - Alignment Target Position</b>	<b>Address: 0296H 0297H</b>
-------------	--	---------------------------------

Operational Interface :	Panel / Software	Communication	Related Section: N/A
-------------------------	------------------	---------------	----------------------

Default : 0

Control Mode : PR

Unit : The pulse unit of Master axis

Range : 0 ~ (P5-84 /P5-83)-1

Data Size : 32-bit

Format : Decimal

Settings : (This function is available in firmware version V1.038 sub26 and later models)

Note: When the input value is over the setting range, an error will occur. Then, the user cannot input the setting value.

Note: When a correct value is already set in P2-75 and does not exceed the setting range, if a change on P5-84 or P5-83 cause the value to exceed the setting range, this parameter will be reset to 0 automatically.

New value of P2-75 = 0 if P2-75 >=(P5-84 /P5-83)

**P2-76**

<b>ALCT</b>	<b>E-Cam Alignment - Source Setting</b>	<b>Address: 0298H 0299H</b>
-------------	---	---------------------------------

Operational Interface :	Panel / Software	Communication	Related Section: N/A
-------------------------	------------------	---------------	----------------------

Default : 0x0000

Control Mode : PR

Unit : N/A

Range : 0x0000 ~ 0x6FF7

Data Size : 16-bit

Format : Hexadecimal

Settings : (This function is available in firmware version V1.038 sub26 and later models)

Format=UZYX. The functions are listed below.

X: E-CAM Alignment Control

Bit	Bit 3	Bit 2	Bit 1	Bit 0
Function	Reserved	Phase Alignment Category	Trigger PR immediately	Enable Alignment
Description	-	Set 0 to disable the function. Set 1 to enable the function. This function is applicable to film delivery control of reverse flying shear.	Set 1 to enable. When the alignment DI is triggered, the correcting error will be calculated and stored in PR specified by P2-73. If this bit is set to 1, trigger the PR immediately after DI activated, otherwise the user should trigger the PR manually or use P5-88.BA to call the PR when E-Cam disengaged.	Set 0 to disable. Set 1 to enable. If enable, the E-CAM alignment correction will be executed when DI.ALGN ON.

Y: Filter intensity

Y	0	1 ~ F
Function	Disabled	Average of 2^Z: Enabled

When the value of Y is increased, the change of correction is getting slow and it can expedite the performance of the filter function. This can avoid the disturbance caused by a sensor noise and a big error to be corrected within one time. Setting P2-76 too big will cause the alignment not able to work properly. The recommendatory value is 3.

UZ: Alignment path definition. Forward direction as setting reference here (0 ~ 100%)

0: Backward alignment only

30: Forward 30%, Backward 70%

50: Alignment with the shortest distance

80: Forward 80%, Backward 20%

>=100: Forward alignment only

<b>P2-77</b>	<b>CMSK</b>	<b>E-Cam Master Axis – Pulse Masking Setting</b>	<b>Address: 029AH 029BH</b>
	Operational Interface :	Panel / Software	Communication
	Default :	0000h	
	Control Mode :	PR	
			Related Section: N/A

Unit :	N/A
Range :	0000h ~ 0xFF7D
Data Size :	16-bit
Format :	Hexadecimal

Settings : (This function is available in firmware version V1.038 sub54 and later models)

X: Pulse masking function of master axis / JOG function of master axis / INCH function of master axis

Y: Correction of lead command length for pulse masking

Y3	Y2	Y1	Y0
-	Extra 1 Cycle	Write to ROM	CALC
-	Calculate the value of P5-87 and plus a cycle of a resolution of pulse command, i.e. (P5-84/P5-83).	Calculate the value of P5-87 and write the value of P5-87 into EEPROM at the same time to ensure the correct position of E-Cam after the servo drive is restarted (after switching power off and on).	Calculate the value of P5-87.

Y=0 → 1: Calculate the value of P5-87 correctly according to actual masking pulse number and additional virtual pulse number.

Y=0 → 2: Calculate the value of P5-87 correctly according to actual masking pulse number and additional virtual pulse number. Then, write the revised value of P5-87 into EEPROM to keep the same phase after the servo drive is restarted.

Y=0 → 7: Calculate the value of P5-87 correctly according to actual masking pulse number and additional virtual pulse number. But, the revised value of P5-87 will plus a value of (P5-84/P5-83) to make lead pulse wait for an E-Cam cycle.

UZ: Pulse data when the master axis performs JOG or INCH function

For example:

Start masking → UZYX = 0x0001

JOG +3Kpps → UZYX = 0x0302

JOG +20Kpps → UZYX = 0x1402

JOG -32Kpps → UZYX = 0x2003

INCH +255 PLS → UZYX = 0xFF04

INCH -18 PLS → UZYX = 0x1205

Complete and correct lead pulse → UZYX = 0x0020 (Write into EEPROM)

Disable this function → UZYX = 0x0000 (This step can be ignored)



<b>P2-78</b>	<b>CMAP</b>	<b>E-Cam: Area Number #2 + (Polarity is Positive)</b>	<b>Address: 029CH 029DH</b>
--------------	-------------	---	---------------------------------

Operational Interface :	Panel / Software	Communication	Related Section: N/A
Default :	270		
Control Mode :	PR		
Unit :	degree (it becomes degree in firmware version V1.038 sub25 and later models)		
Range :	0 ~ 360		
Data Size :	16-bit		
Format :	Decimal		

Settings : P2-78 <= P2-79:

E-Cam degree	0°	~	P2-78	~	P2-79	~	360°
DO:CAM_AREA2	OFF	OFF	ON	ON	ON	OFF	OFF

P2-78 > P2-79:

E-Cam degree	0°	~	P2-79	~	P2-78	~	360°
DO:CAM_AREA2	ON	ON	OFF	OFF	OFF	ON	ON

When the E-Cam is disengaged, the status of digital output, CAM\_AREA2 is always OFF.

<b>P2-79</b>	<b>CMAP</b>	<b>E-Cam: Area Number #2 - (Polarity is Negative)</b>	<b>Address: 029EH 029FH</b>
--------------	-------------	---	---------------------------------

Operational Interface :	Panel / Software	Communication	Related Section: N/A
Default :	360		
Control Mode :	PR		
Unit :	degree (it becomes degree in firmware version V1.038 sub25 and later models)		
Range :	0 ~ 360		
Data Size :	16-bit		
Format :	Decimal		

Settings : P2-78 <= P2-79:

E-Cam degree	0°	~	P2-78	~	P2-79	~	360°
DO:CAM_AREA2	OFF	OFF	ON	ON	ON	OFF	OFF

P2-78 > P2-79:

E-Cam degree	0°	~	P2-79	~	P2-78	~	360°
DO:CAM_AREA2	ON	ON	OFF	OFF	OFF	ON	ON

When the E-Cam is not engaged, the status of digital output, CAM\_AREA2 is always OFF.

<b>P2-80</b>	<b>Z Phase Source of Homing</b>	<b>Address: 02A0H 02A1H</b>
	Operational Interface :	Panel / Software      Communication
	Default :	0x0000
	Control Mode :	PR
	Unit :	-
	Range :	0x0000 ~ 0x0011
	Data Size :	16-bit
	Format :	Hexadecimal

Related Section: N/A

Setting :

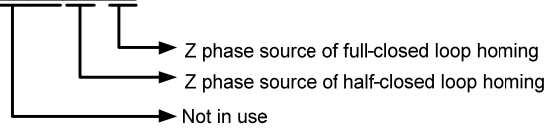

- Z phase source of full-closed loop homing  
0: Auxiliary encoder  
1: Motor
- Z phase source of half-closed loop homing  
0: Motor  
1: Auxiliary encoder

**P3-xx Communication Parameters**

<b>P3-00</b>	<b>ADR</b>	<b>Address Setting</b>		<b>Address: 0300H 0301H</b>
	Operational Interface :	Panel / Software	Communication	Related Section: 9.2
	Default :	0x7F		
	Control Mode :	ALL		
	Unit :	-		
	Range :	0x01 ~ 0x7F		
	Data Size :	16-bit		
	Format :	Hexadecimal		

Settings : The communication address setting is divided into Y, X (hexadecimal):

	0	0	Y	X
Range	-	-	0 ~ 7	0 ~ F

When using RS-232/RS-485 to communicate, one servo drive can only set one address. The duplicate address setting will cause abnormal communication.

This address represents the absolute address of the servo drive in communication network. It is also applicable to RS-232, RS-485, CANopen and DMCENT.

When the communication address setting of MODBUS is set to 0xFF, the servo drive will automatically reply and receive data regardless of the address. However, P3-00 cannot be set to 0xFF.

<b>P3-01</b>	<b>BRT</b>	<b>Transmission Speed</b>	<b>Address: 0302H 0303H</b>
--------------	------------	---------------------------	---------------------------------

Operational Interface : Panel / Software      Communication      Related Section: 9.2

Default : 0x0203

Control Mode : ALL

Unit : bps

Range : 0x0000 ~ 0x0405

Data Size : 16-bit

Format : Hexadecimal

Settings : The setting of transmission speed is divided into Z, Y, X (hexadecimal):

	U	Z	Y	X
Communication Port	DMC	CAN / DMC	-	RS-232/485
Range	0 / 3	0~4	0	0~5

- Definition of X setting value
  - 0: 4800
  - 1: 9600
  - 2: 19200
  - 3: 38400
  - 4: 57600
  - 5: 115200
- Definition of Z setting value
  - 0: 125 Kbit/s
  - 1: 250 Kbit/s
  - 2: 500 Kbit/s
  - 3: 750 Kbit/s
  - 4: 1.0 Mbit/s
- Definition of Y setting value
  - 0: Use Delta's controller, such as PLC and HMI
  - 3: Use Delta's motion card



**NOTE**

- 1) If this parameter is set via CAN, only Z can be set and the others remain.
- 2) The communication speed of USB is 1.0 Mbit/s only and is unchangeable.

P3-02	PTL	Communication Protocol	Address: 0304H 0305H
	Operational Interface :	Panel / Software      Communication	Related Section: 9.2
	Default :	6	
	Control Mode :	ALL	
	Unit :	-	
	Range :	0 ~ 0x8	
	Data Size :	16-bit	
	Format :	Hexadecimal	
	Settings :	The definition of the setting value is as the followings: 0: 7, N, 2 (MODBUS, ASCII) 1: 7, E, 1 (MODBUS, ASCII) 2: 7, O, 1 (MODBUS, ASCII) 3: 8, N, 2 (MODBUS, ASCII) 4: 8, E, 1 (MODBUS, ASCII) 5: 8, O, 1 (MODBUS, ASCII) 6: 8, N, 2 (MODBUS, RTU) 7: 8, E, 1 (MODBUS, RTU) 8: 8, O, 1 (MODBUS, RTU)	

P3-03	FLT	Communication Error Disposal	Address: 0306H 0307H
	Operational Interface :	Panel / Software      Communication	Related Section: 9.2
	Default :	0	
	Control Mode :	ALL	
	Unit :	-	
	Range :	0 ~ 0x1	
	Data Size :	16-bit	
	Format :	Hexadecimal	
	Settings :	The definition of the setting value is as the following: 0: Warning and keeps running 1: Warning and stops deceleration (The deceleration time is set to parameter P5-03.B)	

P3-04	CWD	Communication Timeout	Address: 0308H 0309H
Operational Interface :		Panel / Software	Communication
Default :		0	
Control Mode :		ALL	
Unit :		sec	
Range :		0 ~ 20	
Data Size :		16-bit	
Format :		DEC	
Settings : If the setting value is not 0, enable communication timeout immediately. If it is set to 0, disable the function.			

P3-05	CMM	Communication Mechanism	Address: 030AH 030BH
Operational Interface :		Panel / Software	Communication
Default :		0	
Control Mode :		ALL	
Unit :		-	
Range :		0x00 ~ 0x01	
Data Size :		16-bit	
Format :		Hexadecimal	
Settings : Communication port can select one or more than one communications.			
<ul style="list-style-type: none"> <li>● Communication Interface           <ul style="list-style-type: none"> <li>0: RS232</li> <li>1: RS485</li> </ul> </li> </ul>			

P3-06	SDI	Control Switch of Digital Input (DI)	Address: 030CH 030DH
	Operational Interface :	Panel / Software      Communication	Related Section: 9.2
	Default :	0	
	Control Mode :	ALL	
	Unit :	-	
	Range :	0x0000 ~ 0x3FFF	
	Data Size :	16-bit	
	Format :	Hexadecimal	
	Settings :	<p>The source of DI controls the switch.</p> <p>Each bit of this parameter decides one input source of DI signal:            Bit0 ~ Bit7 correspond to DI1 ~ DI8.            Bit8 ~ Bit13 correspond to extended DI EDI9 ~ EDI14;            The setting of bit is as the followings:            0: The input status is controlled by the external hardware.            1: The input status is controlled by P4-07.</p> <p>For the functional planning of digital input, please refer to:            DI1 ~ DI8: P2-10 ~ P2-17            EDI9 ~ EDI14: P2-36 ~ P2-41</p>	

P3-07	CDT	Communication Response Delay Time	Address: 030EH 030FH
	Operational Interface :	Panel / Software      Communication	Related Section: 9.2
	Default :	0	
	Control Mode :	ALL	
	Unit :	1ms	
	Range :	0 ~ 1000	
	Data Size :	16-bit	
	Format :	Decimal	
	Settings :	<p>Delay the time of communication response from servo drive to controller</p>	

<b>P3-08</b>	<b>MNS</b>	<b>Monitor Mode</b>		<b>Address: 0310H 0311H</b>
	Operational Interface :	Panel / Software	Communication	Related Section: 9.2
	Default :	0000		
	Control Mode :	ALL		
	Unit :	-		
	Range :	Shown as below		
	Data Size :	16-bit		
	Format :	Hexadecimal		

Settings : The setting of monitor mode is divided into L and H. (hexadecimal):

Item	-	-	L	H
Function	-	-	Low-speed monitoring time	Monitor Mode
Range	0	0	0 ~ F	0 ~ 3

The status of this axis or multi-axis can be monitored by USB. The definition of setting value is as follows:

- The definition of H setting value
  - 3: USB is high-speed monitor. The sampling frequency is 16K and can only monitor 2CH.
  - 2: USB is high-speed monitor. The sampling frequency is 8K and can monitor 4CH.
  - 1: USB is low-speed monitor. The sampling time is set by L and can monitor 4CH.
  - 0: disable the monitor function
- L: the sampling time of USB low-speed monitor. Its unit is ms. It means the axial status will be set via USB every L ms. So the controller can monitor the axial status. Each monitoring message includes 4 CH data (16 bit x 4). If L is set to 0, this function is disabled. L is enabled when H is set to 1.



<b>P3-09</b>	<b>SYC</b>	<b>CANopen / DMCNET Synchronize Setting</b>	<b>Address: 0312H 0313H</b>
	Operational Interface :	Panel / Software      Communication	Related Section: 9.2
	Default :	0x5055 (for -B, -L, -M, -U type) 0x3511 (for -F type)	
	Control Mode :	CANopen / DMCNET	
	Unit :	-	
	Range :	Shown as below	
	Data Size :	16-bit	
	Format :	Hexadecimal	

Settings : The synchronous setting of CANopen / DMCNET is divided into E, T, D and M (hexadecimal):

Item	E	T	D	M
Function	Range of Synchronous error	Target Value	Deadband	Adjusting amount
Range	1 ~ 9	0 ~ 9	0 ~ F	1 ~ F

The slave of CANopen / DMCNET synchronizes with the master via SYNC. See as the followings:

- M: If the slave needs to synchronize with the master, correct the clock is a must. This parameter sets the maximum correction value per time. (Unit: usec)
- D: Set the size of deadband (Unite: usec). If the deviation between the SYNC reaching time and the target value does not exceed the deadband, correction is no need.
- T: SYNC arrival time. The standard value is 500usec but it might be different from the target value. Thus, the buffer is necessary.  
 Target value = 400 + 10 x T.  
 For instance, if T=5, the target value will be 450.
- E: If the deviation between SYNC reaching time and the target value is smaller than the range, it means the synchronization is successful. (Unit: 10 usec)

<b>P3-10</b>	<b>CANEN</b>	<b>CANopen / DMCNET Protocol Setting</b>	<b>Address: 0314H 0315H</b>
	Operational Interface :	Panel / Software	Communication
	Default :	0x0000	
	Control Mode :	CANopen / DMCNET	
	Unit :	-	
	Range :	Shown as below	
	Data Size :	16-bit	
	Format :	Hexadecimal	

Related Section:  
Section 9.2

Settings : CANopen / DMCNET synchronization setting is divided into X, Y, Z, U (hexadecimal):

Item	U	Z	Y	X
Function	If PDO alarm will be cleared automatically	Reserved	If motor will servo off when CAN Bus / DMCNET error occurs	Reserved
Range	0 ~ 1	0 ~ F	0 ~ 1	0 ~ 1

Definition:

X: Reserved

Y: 0: The motor keeps running when communication error occurs;  
1: The motor servo Off when communication error occurs.

Z: Reserved

U: 0: If PDO error occurs, it must be cleared by Alarm Rest  
1: If PDO error occurs, it will be cleared automatically.

Note:

For A2-M, X bit is invalid.

For A2-F, it is suggested to set X to 1.

<b>P3-11</b>	<b>CANOP</b>	<b>CANopen / DMCNET Selection</b>	<b>Address: 0316H 0317H</b>
	Operational Interface :	Panel / Software	Communication
	Default :	0x0000	
	Control Mode :	CANopen / DMCNET	
	Unit :	-	
	Range :	Shown as below	
	Data Size :	16-bit	
	Format :	Hexadecimal	

Related Section:  
Section 9.2

Settings : Synchronous / DMCNET setting of CANopen is divided into X, Y, Z and U (hexadecimal):

Item	U	Z	Y	X
Function	Undefined	Undefined	Undefined	Whether the parameter is saved into EEPROM
Range	-0 ~ 1	0 ~ F	0 ~ F	0 ~ 1

The definition is as follows:

X = 1: When writing parameters via PDO, parameters will be saved in EEPROM.

X = 0: When writing parameters via PDO, parameters will not be saved in EEPROM.

Y, Z, U : Undefined



**NOTE** If X is set to 1 and write parameters by PDO continuously, it will shorten the lifetime of EEPROM.

<b>P3-12</b>	<b>QSTPO</b>	<b>CANopen / DMCNET Support Setting</b>	<b>Address: 0318H 0319H</b>
	Operational Interface :	Panel / Software	Communication
	Default :	0x0000	
	Control Mode :	CANopen / DMCNET	
	Unit :	-	
	Range :	0x0000 ~ 0x0111	
	Data Size :	16-bit	
	Format :	Hexadecimal	

Related Section:  
Section 9.2

Settings : CANopen / DMCNET synchronization setting is divided into X, Y, Z, U (hexadecimal):

Item	U	Z	Y	X
Function	None	CANopen / DMCNET value will be loaded in	If the motor will enter Quick Stop mode when in auto protection.	If OD-6040 supports Quick Stop
Range	None	0~1	0 ~ 1	0 ~ 1

Aiming to CANopen Quick Stop mode, we have X and Y setting (Hexadecimal.) which is showed as below. It is only suitable in CAN mode: oxb mode selection (P1-01 = b).

X: Trigger Servo ON sequence and Quick Stop support setting

X = 0: Servo On the servo drive by turning On OD-6040 Bit 3 (Enable Operation). OD-6040 Bit 2 enters Quick Stop mode is not supported.

X = 1: The servo drive can be Servo ON only when OD-6040 Bit 0, Bit 1, Bit 3 are ON. And will enter Quick Stop mode via OD-6040 Bit 2 (Quick Stop)

Y: When warning alarms (positive / negative limit, communication error, under voltage, abnormal fan) occur, it can determine if Quick Stop mode can be triggered.

Y = 0: When warning alarms occur, if motor decelerates to stop because of auto protection function, it will not enter Quick Stop mode. Users only need to troubleshoot the alarm and clear the alarm message from the servo drive, the servo drive status will resume.

Y = 1: When warning alarms occur, if motor decelerates to stop because of auto protection function, OD-6040 will enter Quick Stop mode. Users have to issue Fault Reset to continue other commands and clear the alarm message from the servo drive.

The following table shows P parameters and its corresponding CANopen OD or DMCNET parameter. The setting of Z (Hexadecimal.) can determine if it should be modified. This function is applicable in CAN mode: 0xB or 0xC (P1-01 = b or c) or DMC mode: 0xB (P1-01 = b).

Z: Determine if the value of OBJECT will overlap parameters from P groups.

Z = 0: When re-servo on the servo drive or reset the communication, P parameters that mentioned in the following table will load in the default value in CANopen /DMCNET mode.

Z = 1: When re-servo on the servo drive or reset the communication, P parameters that mentioned in the following table will keep the value that before power off.

CANopen mode:

Related variables during initialization	P3-12.Z = 0	P3-12.Z = 1	Note
P1-32	0x0010	EEPROM	
P2-35	3840000	EEPROM	

P1-47	10	EEPROM	
P1-49	0	EEPROM	
P1-38	100	EEPROM	
Home offset	0	EEPROM	Used in HM mode
P1-44	1	EEPROM	
P1-45	1	EEPROM	

## DMCNET mode:

Related variables during initialization	P3-12.Z = 0	P3-12.Z = 1	Note
P1-32	0x0010	EEPROM	
P2-35	3840000	EEPROM	
P1-47	100	EEPROM	
P1-49	0	EEPROM	
P1-38	100	EEPROM	
Home offset	0	Undefined	Used in HM mode
Acc	200	Undefined	Used in PV, PP mode
Dec	200	Undefined	Used in PV, PP mode
P1-44	1	EEPROM	
P1-45	1	EEPROM	

Methods that save parameters in EEPROM (even when the power is off):

SDO: When setting parameters, parameters will be stored in EEPROM.

PDO: Please refer to the setting of P3-11.X

X = 1: When setting parameters via PDO, parameters will be stored in EEPROM.

X = 0: When setting parameters via PDO, parameters will not be stored in EEPROM.

Note: In CANopen mode, when using the function of OD 1010 Store Parameter and P3-12.Z = 0, the default value will be different from the value that showed above. Please refer to CANopen Standard for further information.

**P4-xx Diagnosis Parameters**

P4-00★	ASH1	Fault Record (N)	Address: 0400H 0401H
Operational Interface :		Panel / Software	Related Section: 4.4.1
		Communication	
Default :		0	
Control Mode :		ALL	
Unit :		-	
Range :		-	
Data Size :		32-bit	
Format :		Hexadecimal	
Settings : The last abnormal status record Low word: LXXXX: display ALM number High word: hYYYY: display the error code corresponds to CANopen / DMCNET.			

P4-01★	ASH2	Fault Record (N-1)	Address: 0402H 0403H
Operational Interface :		Panel / Software	Related Section: 4.4.1
		Communication	
Default :		0	
Control Mode :		ALL	
Unit :		-	
Range :		-	
Data Size :		32-bit	
Format :		Hexadecimal	
Settings : The last second abnormal status record Low word: LXXXX: display ALM number High word: hYYYY: display the error code corresponds to CANopen / DMCNET			

P4-02★	ASH3	Fault Record (N-2)	Address: 0404H 0405H
	Operational Interface :	Panel / Software      Communication	Related Section: 4.4.1
	Default :	0	
	Control Mode :	ALL	
	Unit :	-	
	Range :	-	
	Data Size :	32-bit	
	Format :	Hexadecimal	
	Settings :	The last third abnormal status record Low word: LXXXX: display ALM number High word: hYYYY: display the error code corresponds to CANopen / DMCNET	

P4-03★	ASH4	Fault Record (N-3)	Address: 0406H 0407H
	Operational Interface :	Panel / Software      Communication	Related Section: 4.4.1
	Default :	0	
	Control Mode :	ALL	
	Unit :	-	
	Range :	-	
	Data Size :	32-bit	
	Format :	Hexadecimal	
	Settings :	The last fourth abnormal status record Low word: LXXXX: display ALM number High word: hYYYY: display the error code corresponds to CANopen / DMCNET	

P4-04★	ASH5	Fault Record (N-4)	Address: 0408H 0409H
Operational Interface :		Panel / Software	Communication
Default :		0	
Control Mode :		ALL	
Unit :		-	
Range :		-	
Data Size :		32-bit	
Format :		Hexadecimal	
Settings :		The last fifth abnormal status record Low word: LXXXX: display ALM number High word: hYYYY: display the error code corresponds to CANopen / DMCNET	
Related Section: 4.4.1			

P4-05	JOG	Servo Motor Jog Control	Address: 040AH 040BH
Operational Interface :		Panel / Software	Communication
Default :		20	
Control Mode :		ALL	
Unit :		r/min	
Range :		0 ~ 5000	
Data Size :		16-bit	
Format :		Decimal	
Settings :		Three control methods are as follows:	
		1. Operation Test	
		After the JOG speed is set by P4-05 via panel, the panel will display the symbol of JOG. Pressing the UP Key can control JOG operation in positive direction, pressing the DOWN Key can control negative direction. Stop pressing to stop the JOG operation. If there is any error in this setting, then the motor cannot operate. The maximum JOG speed is the maximum speed of the servo motor.	
		2. DI Control	
		If the DI is set to JOGU and JOGD (refer to table 8.1), then the JOG operation in positive or negative direction can be controlled via this DI.	
Related Section: 4.4.2			



- 3. Communication Control
  - 1 ~ 5000: JOG speed
  - 4998: JOG operation in positive direction
  - 4999: JOG operation in negative direction
  - 0: Stop operation

 **NOTE** When writing via communication, if the frequency is high, please set P2-30 to 5.

P4-06 ▲ ■	FOT	Digital Output Register (Readable and Writable)	Address: 040CH 040DH
	Operational Interface :	Panel / Software	Communication
	Default :	0	
	Control Mode :	ALL	
	Unit :	-	
	Range :	0 ~ 0xFF	
	Data Size :	16-bit	
	Format :	Hexadecimal	
	Settings :	bit 00: correspond to DO code=0x30 bit 01: correspond to DO code=0x31 bit 02: correspond to DO code=0x32 bit 03: correspond to DO code=0x33 bit 04: correspond to DO code=0x34 bit 05: correspond to DO code=0x35 bit 06: correspond to DO code=0x36 bit 07: correspond to DO code=0x37 bit 08: correspond to DO code=0x38 bit 09: correspond to DO code=0x39 bit 10: correspond to DO code=0x3A bit 11: correspond to DO code=0x3B bit 12: correspond to DO code=0x3C bit 13: correspond to DO code=0x3D bit 14: correspond to DO code=0x3E bit 15: correspond to DO code=0x3F If P2-18 is set to 0x0130, then the DO#1 is bit 0 status of P4-06. DO Code (0x30~0x3F) can be set via communication DO, and then write into P4-06.	

P4-07	ITST	Multi-function of Digital Input	Address: 040EH 040FH
Operational Interface :	Panel / Software	Communication	Related Section: Section 4.4.4 Table 9.2
Default :	0		
Control Mode :	ALL		
Unit :	-		
Range :	0 ~ 0x3FFF		
Data Size :	16-bit		
Format :	Hexadecimal		
Settings :	The DI input signal can come from external terminal (DI1 ~ DI8; EDI9 ~ EDI14) or software SDI1 ~ 14 (Bit 0 ~ 13 of corresponding parameter P4-07) and is determined by P3-06. The corresponding bit of P3-06 is 1, which means the source is software SDI (P4-07). If the corresponding bit is 0, then the source is hardware DI. See the following graph:		

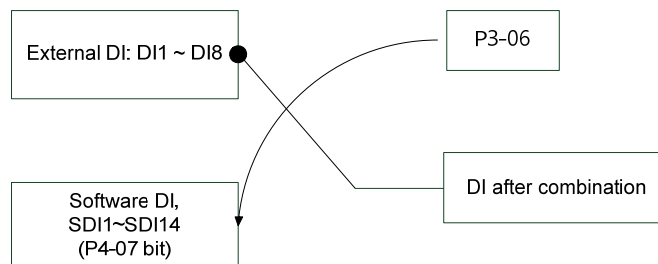

Read parameters: shows the DI status after combination

Write parameters: writes the software SDI status

For example:

The value of reading P4-07 is 0x0011, which means DI1 and DI5 is ON after combination.

The value of writing P4-07 is 0x0011, which means software SDI1 and SDI5 is ON.

Please refer to P2-10 ~ P2-17 for the function program of digital input pin DI (DI1~DI8) and P2-36 ~ P2-41 for extended DI (EDI9 ~ EDI14).

P4-08★	PKEY	Input Status of the Drive Keypad (Read-only)	Address: 0410H 0411H
	Operational Interface :	Panel / Software      Communication	Related Section: -
	Default :	-	
	Control Mode :	ALL	
	Unit :	-	
	Range :	(read-only)	
	Data Size :	16-bit	
	Format :	Hexadecimal	
	Settings :	The aim is to check if the five Keys, MODE, UP, DOWN, SHIFT and SET can work normally. This parameter is also used to check if the Keys are all functional when producing servo drives.	

P4-09★	MOT	Digital Output Status (Read-only)	Address: 0412H 0413H
	Operational Interface :	Panel / Software      Communication	Related Section: 4.4.5
	Default :	-	
	Control Mode :	ALL	
	Unit :	-	
	Range :	0 ~ 0x1F	
	Data Size :	16-bit	
	Format :	Hexadecimal	
	Settings :	Note: There is no difference whether read by panel or communication.	

P4-10■	CEN	Adjustment Selection	Address: 0414H 0415H
	Operational Interface :	Panel / Software      Communication	Related Section: -
	Default :	0	
	Control Mode :	ALL	
	Unit :	-	

Range :	0 ~ 6
Data Size :	16-bit
Format :	Decimal

Settings : 0: reserved

- 1: Execute the adjustment of analog speed input offset
- 2: Execute the adjustment of analog torque input offset
- 3: Execute the adjustment of current detector (V phase) hardware offset
- 4: Execute the adjustment of current detector (W phase) hardware offset
- 5: Execute the adjustment of 1~4 hardware offset
- 6: Execute the adjustment of IGBT ADC

**NOTE**

The adjustment function needs to be enabled by the setting of parameter P2-08. When adjusting, the external wiring which connects to analog speed or torque needs to be removed completely and must be in Servo Off status.

P4-11	SOF1	Analog Speed Input Offset Adjustment 1	Address: 0416H 0417H
Operational Interface :		Panel / Software	Communication
Default :		Factory default	
Control Mode :		ALL	
Unit :		-	
Range :		0 ~ 32767	
Data Size :		16-bit	
Format :		Decimal	

Settings : Manually adjust the hardware offset. The adjustment function needs to be enabled by the setting of parameter P2-08. It is not suggested to adjust the auxiliary adjustment. This parameter cannot be reset.

P4-12	SOF2	Analog Speed Input Offset Adjustment 2	Address: 0418H 0419H
Operational Interface :		Panel / Software	Communication
Default :		Factory default	
Control Mode :		ALL	
Unit :		-	
Range :		0 ~ 32767	
Data Size :		16-bit	
Format :		Decimal	
Settings : Manually adjust the hardware offset. The adjustment function needs to be enabled by the setting of parameter P2-08. It is not suggested to adjust the auxiliary adjustment. This parameter cannot be reset.			

P4-13	TOF1	Analog Torque Input Offset Adjustment 1	Address: 041AH 041BH
Operational Interface :		Panel / Software	Communication
Default :		Factory default	
Control Mode :		ALL	
Unit :		-	
Range :		0 ~ 32767	
Data Size :		16-bit	
Format :		Decimal	
Settings : Manually adjust the hardware offset. The adjustment function needs to be enabled by the setting of parameter P2-08. It is not suggested to adjust the auxiliary adjustment. This parameter cannot be reset.			

P4-14	TOF2	Analog Torque Input Offset Adjustment 2	Address: 041CH 041DH
Operational Interface :		Panel / Software	Communication
Default :		Factory default	
Control Mode :		ALL	
Unit :		-	
Range :		0 ~ 32767	
Data Size :		16-bit	
Format :		Decimal	
Settings : Manually adjust the hardware offset. The adjustment function needs to be enabled by the setting of parameter P2-08. It is not suggested to adjust the auxiliary adjustment. This parameter cannot be reset.			

P4-15	COF1	Current Detector (V1 Phase) Offset Adjustment	Address: 041EH 041FH
Operational Interface :		Panel / Software	Communication
Default :		Factory default	
Control Mode :		ALL	
Unit :		-	
Range :		0 ~ 32767	
Data Size :		16-bit	
Format :		Decimal	
Settings : Manually adjust the hardware offset. The adjustment function needs to be enabled by the setting of parameter P2-08. It is not suggested to adjust the auxiliary adjustment. This parameter cannot be reset.			

P4-16	COF2	Current Detector (V2 Phase) Offset Adjustment	Address: 0420H 0421H
Operational Interface :		Panel / Software	Communication
Default :		Factory default	
Control Mode :		ALL	
Unit :		-	
Range :		0 ~ 32767	
Data Size :		16-bit	
Format :		Decimal	
Settings : Manually adjust the hardware offset. The adjustment function needs to be enabled by the setting of parameter P2-08. It is not suggested to adjust the auxiliary adjustment. This parameter cannot be reset.			

P4-17	COF3	Current Detector (W1 Phase) Offset Adjustment	Address: 0422H 0423H
Operational Interface :		Panel / Software	Communication
Default :		Factory default	
Control Mode :		ALL	
Unit :		-	
Range :		0 ~ 32767	
Data Size :		16-bit	
Format :		Decimal	
Settings : Manually adjust the hardware offset. The adjustment function needs to be enabled by the setting of parameter P2-08. It is not suggested to adjust the auxiliary adjustment. This parameter cannot be reset.			

P4-18	COF4	Current Detector (W2 Phase) Offset Adjustment	Address: 0424H 0425H
Operational Interface :		Panel / Software	Communication
Default :		Factory default	
Control Mode :		ALL	
Unit :		-	
Range :		0 ~ 32767	
Data Size :		16-bit	
Format :		Decimal	
Settings : Manually adjust the hardware offset. The adjustment function needs to be enabled by the setting of parameter P2-08. It is not suggested to adjust the auxiliary adjustment. This parameter cannot be reset.			

P4-19	TIGB	IGBT NTC Adjustment Detection Level (cannot reset)	Address: 0426H 0427H
Operational Interface :		Panel / Software	Communication
Default :		Factory default	
Control Mode :		ALL	
Unit :		-	
Range :		1 ~ 4	
Data Size :		16-bit	
Format :		Decimal	
Settings : Please cool down the drive to 25 Celsius degree when adjusting			



P4-20	DOF1	Offset Adjustment Value of Analog Monitor Output (Ch1)	Address: 0428H 0429H
	Operational Interface :	Panel / Software      Communication	Related Section: 6.4.4
	Default :	0	
	Control Mode :	ALL	
	Unit :	mV	
	Range :	-800 ~ 800	
	Data Size :	16-bit	
	Format :	Decimal	
	Settings :	Offset adjustment value (cannot reset)	

P4-21	DOF2	Offset Adjustment Value of Analog Monitor Output (Ch2)	Address: 042AH 042BH
	Operational Interface :	Panel / Software      Communication	Related Section: 6.4.4
	Default :	0	
	Control Mode :	ALL	
	Unit :	mV	
	Range :	-800 ~ 800	
	Data Size :	16-bit	
	Format :	Decimal	
	Settings :	Offset adjustment value (cannot reset)	

P4-22	SAO	Analog Speed Input OFFSET	Address: 042CH 042DH
	Operational Interface :	Panel / Software      Communication	Related Section: -
	Default :	0	
	Control Mode :	S	
	Unit :	mV	

Range :	-5000 ~ 5000
Data Size :	16-bit
Format :	Decimal
Settings :	Users manually adjust the OFFSET

<b>P4-23</b>	<b>TAO</b>	<b>Analog Torque Input OFFSET</b>	<b>Address: 042EH 042FH</b>
	Operational Interface :	Panel / Software	Communication
	Default :	0	
	Control Mode :	T	
	Unit :	mV	
	Range :	-5000 ~ 5000	
	Data Size :	16-bit	
	Format :	Decimal	
	Settings :	Users manually adjust the OFFSET	

## 220V Series

<b>P4-24</b>	<b>LVL</b>	<b>Level of Under voltage Error</b>	<b>Address: 0430H 0431H</b>
	Operational Interface :	Panel / Software	Communication
	Default :	160	
	Control Mode :	ALL	
	Unit :	V (rms)	
	Range :	140~190	
	Data Size :	16-bit	
	Format :	Decimal	
	Settings :	When the voltage of DC BUS is lower than $P4-24 * \sqrt{2}$ , the under voltage alarm occurs.	

**400V Series**

<b>P4-24</b>	<b>LVL</b>	<b>Level of Under voltage Error</b>	<b>Address: 0430H 0431H</b>
	Operational Interface :	Panel / Software      Communication	Related Section: -
	Default :	320	
	Control Mode :	ALL	
	Unit :	V (rms)	
	Range :	140~380	
	Data Size :	16-bit	
	Format :	Decimal	

Settings : When the voltage of DC BUS is lower than  $P4-24 * \sqrt{2}$  , the under voltage alarm occurs.

**P5-xx Motion Setting Parameters**

<b>P5-00 ~ P5-02</b>	Reserved
----------------------	----------

<b>P5-03</b>	<b>PDEC Deceleration Time of Auto Protection</b>	<b>Address: 0506H 0507H</b>
--------------	--	---------------------------------

Operational Interface :	Panel / Software	Communication	Related Section: -
Default :	0XEEEFEEFF		
Control Mode :	ALL		
Unit :	-		
Range :	0x00000000 ~ 0xFFFFFFFF		
Data Size :	32-bit		
Format :	Hexadecimal		
Settings :	The parameter setting is divided into D, C, B, A, W, Z, Y, X (hexadecimal), including:		

1. The deceleration time when activating the auto-protection function: OVF (DO.0x11, position command / feedback overflows), CTO (communication timeout AL020), SPL, SNL, PL, NL
2. Deceleration time of Stop Command: STP

Item	D	C	B	A	W	Z	Y	X
Function	STP	PFQS	CTO	OVF	SNL	SPL	NL	PL
Range	0 ~ F	0 ~ F	0 ~ F	0 ~ F	0 ~ F	0 ~ F	0 ~ F	0 ~ F

0 ~ F is used to indexing the deceleration time of P5-20~P5-35.  
 For example: If X is set to A, then the deceleration time of PL is determined by P5-30.

<b>P5-04</b>	<b>HMOV Homing Mode</b>	<b>Address: 0508H 0509H</b>
--------------	-------------------------	---------------------------------

Operational Interface :	Panel / Software	Communication	Related Section: -
Default :	0		
Control Mode :	PR		
Unit :	-		
Range :	0 ~ 0x128		

Data Size :	16-bit
Format :	Hexadecimal

Settings :

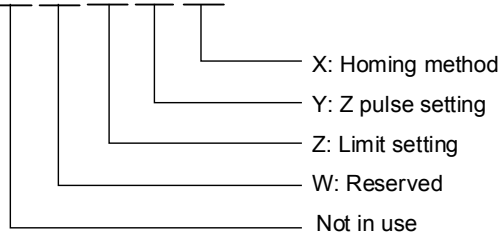

The definition of the setting value is as the followings:

W	Z	Y	X
Reserved	Limit Setting	Z pulse Setting	Homing Method
-	0 ~ 1	0 ~ 2	0 ~ 8
		Y = 0: Stop and return to Z pulse	X = 0: Homing in forward direction and regard PL as the homing origin.
		Y = 1: Go forward to Z pulse	X = 1: Homing in reverse direction and regard NL as the homing origin.
		Y = 2: Do not look for Z pulse	X = 2: Homing in forward direction ORGP: OFF > ON, as the homing origin
	When encounter limit: Z = 0: shows error Z = 1: rotates backwards		X = 3: Homing in reverse direction ORGP: OFF > ON, as the homing origin
			X = 4: Look for Z pulse in forward direction and regard it as the homing origin
			X = 5: Look for Z pulse in reverse direction and regard it as the homing origin
			X = 6: Homing in forward direction ORGP: ON > OFF, as the homing origin
			X = 7: Homing in reverse direction ORGP: ON > OFF, as the homing origin

W	Z	Y	X
Reserved	Limit Setting	Z pulse Setting	Homing Method
-	0 ~ 1	0 ~ 2	0 ~ 8
	When encounter limit: Z = 0: shows error Z = 1: rotates backwards	Y = 0: Stop and return to Z pulse	X = 7: Homing in reverse direction ORGP: ON > OFF, as the homing origin
		Y = 1: Go forward to Z pulse	X = 8: directly define the current position as the origin
		Y = 2: Do not look for Z pulse	X = 9: Regard the collision point as the original point in forward direction
		Y = 0: Return to Z pulse Y = 1: Do not look for Z pulse	X = A: Regard the collision point as the original point in reverse direction

<b>P5-05</b>	<b>HSPD1</b>	<b>1<sup>st</sup> Speed Setting of High Speed Homing</b>	<b>Address: 050AH 050BH</b>
--------------	--------------	--	---------------------------------

Operational Interface :	Panel / Software	Communication	Related Section: -
Default :	100.0	1000	
Control Mode :	(This has to be set with P5-04)		
Unit :	1 r/min	0.1 r/min	
Range :	0.1 ~ 2000.0	1 ~ 20000	
Data Size :	32-bit		
Format :	Decimal		
Example :	1.5 = 1.5 r/min	15 = 1.5 r/min	

Settings : The 1<sup>st</sup> speed of high speed homing

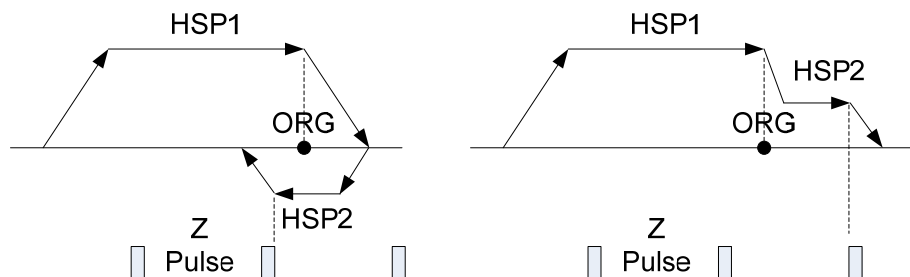

P5-06	HSPD2	2 <sup>nd</sup> Speed Setting of Low Speed Homing	Address: 050CH 050DH
Operational Interface :	Panel / Software	Communication	Related Section: -
Default :	20.0	200	
Control Mode :	PR (This has to be set with P5-04)		
Unit :	1 r/min	0.1 r/min	
Range :	0.1 ~ 2000.0	1 ~ 20000	
Data Size :	16-bit		
Format :	Decimal		
Example :	1.5 = 1.5 r/min	15 = 1.5 r/min	
Settings :	The 2 <sup>nd</sup> speed setting of low speed homing		

P5-07 ■	PRCM	Trigger Position Command (PR mode only)	Address: 050EH 050FH
Operational Interface :	Panel / Software	Communication	Related Section: -
Default :	0		
Control Mode :	PR		
Unit :	-		
Range :	0 ~ 1000		
Data Size :	16-bit		
Format :	Decimal		
Settings :	<p>Set P5-07 to 0 to start homing</p> <p>Set P5-07 to 1~63 to execute PR procedure which is the same as DI.CTRG+POS<sub>n</sub></p> <p>It is prohibited to set P5-07 to 64 ~ 9999 (The value exceeds the valid range)</p> <p>Set P5-07 to 1000 to execute Stop Command which is the same as DI.STP</p> <p>When reading P5-07:</p> <p>If the command is incomplete, the drive will read the current command.</p> <p>If the command is completed, the drive will read the current command + 10000.</p> <p>If the command is completed and DO.TPOS is ON, reach the motor position, the drive will read the current command +20000.</p>		

When PR is triggered by DI, the reading value is the same

For example:

Set P5-07 to 3, PR#3 will be triggered.

If the reading value is 3, it means PR #3 is incomplete.

If the reading value is 10003, it means PR#3 is issued completed, but the motor has not reached the target position yet.

If the reading value is 20003, it means PR#3 is issued completed and the motor has reached the target position.

P5-08	SWLP	Forward Software Limit	Address: 0510H 0511H
Operational Interface :	Panel / Software	Communication	Related Section: -
Default :	2147483647		
Control Mode :	PR		
Unit :	PUU		
Range :	-2147483648 ~ +2147483647		
Data Size :	32-bit		
Format :	Decimal		
Settings :	In PR mode, if the motor rotates in forward direction and its command position exceeds the setting value of P5-08, it will trigger AL.283.		

P5-09	SWLN	Reverse Software Limit	Address: 0512H 0513H
Operational Interface :	Panel / Software	Communication	Related Section: -
Default :	-2147483648		
Control Mode :	PR		
Unit :	PUU		
Range :	-2147483648 ~ +2147483647		
Data Size :	32-bit		
Format :	Decimal		
Settings :	In PR mode, if the motor rotates in reverse direction and its command position exceeds the setting value of P5-09, it will trigger AL.285.		



P5-10★	AYSZ	Data Array - Data Size	Address: 0514H 0515H
	Operational Interface :	Panel / Software	Communication
	Default :	-	
	Control Mode :	ALL	
	Unit :	-	
	Range :	Read-only	
	Data Size :	16-bit	
	Format :	Decimal	
	Settings :	Data size (N x 32 bits) means size N of data array	
			Related Section: 7.2

P5-11■	AYID	Data Array - Address of Reading / Writing	Address: 0516H 0517H
	Operational Interface :	Panel / Software	Communication
	Default :	0	
	Control Mode :	ALL	
	Unit :	-	
	Range :	0 ~ (value set by P5-10 minus 1)	
	Data Size :	16-bit	
	Format :	Decimal	
	Settings :	The address of specified data when reading or writing data array.	
			Related Section: 7.2

P5-12	AYD0	Data Array - Window #1 for Reading / Writing	Address: 0518H 0519H
Operational Interface :		Panel / Software	Communication
Default :		0	
Control Mode :		ALL	
Unit :		-	
Range :		-2147483648 ~ +2147483647	
Data Size :		32-bit	
Format :		Decimal	
Settings : Window #1 (Array[P5-11++])			
When reading the parameter via panel, the value set by P5-11 will not add 1, but the others will.			

P5-13	AYD1	Data Array - Window #2 for Reading / Writing	Address: 051AH 051BH
Operational Interface :		Panel / Software	Communication
Default :		0	
Control Mode :		ALL	
Unit :		-	
Range :		-2147483648 ~ +2147483647	
Data Size :		32-bit	
Format :		Decimal	
Settings : Window #2 (Array[P5-11++])			
When reading and writing the parameter via panel or communication, the value set by P5-11 will add 1. Panel is write-protected.			

P5-14	Reserved
-------	----------

P5-15	PMEM	PATH#1 ~ PATH#2 No Data Retained Setting	Address: 051EH 051FH
Operational Interface :		Panel / Software	Communication
Related Section: -			
Default : 0x0			
Control Mode :		ALL	
Unit : -			
Range : 0x0 ~ 0x0011			
Data Size : 16-bit			
Format : Hexadecimal			
Settings : The parameter is divided into 00YX: X=0: PATH#1 Data retained X=1: PATH#1 No data retained Y=0: PATH#2 Data retained Y=1: PATH#2 No data retained Others are reserved Users can continuously write the new position into the drive through communication by P5-05.			

P5-16	AXEN	Axis Position - Motor Encoder	Address: 0520H 0521H
Operational Interface :		Panel / Software	Communication
Related Section: 7.3			
Default : 0			
Control Mode :		ALL	
Unit : PUU (User position unit)			
Range : -2147483648 ~ +2147483647			
Data Size : 32-bit			
Format : Decimal			
Settings : Read: The feedback position of the motor encoder, which is the monitor various V000 + the offset value. (This function is supported after firmware version V1.015) Write: Any value can be written into the parameter and will neither change V000 nor influence the positioning coordinate system. It is only for observation when adjusting the offset value.			

P5-17	AXAU	Axis Position - Auxiliary Encoder	Address: 0522H 0523H
Operational Interface :		Panel / Software	Communication
Default :		-	
Control Mode :		ALL	
Unit :		Pulse number	
Range :		-2147483648 ~ +2147483647	
Data Size :		32-bit	
Format :		Decimal	
Settings : Sends back: pulse counts of the auxiliary encoder (linear scale)			

P5-18	AXPC	Axis Position - Pulse Command	Address: 0524H 0525H
Operational Interface :		Panel / Software	Communication
Default :		-	
Control Mode :		ALL	
Unit :		Pulse number	
Range :		-2147483648 ~ +2147483647	
Data Size :		32-bit	
Format :		Decimal	
Settings : Sends back: pulse counts of pulse command			

P5-19	TBS	E-Cam Curve Scaling	Address: 0526H 0527H
Operational Interface :		Panel / Software	Communication
Default :		1.000000	
Control Mode :		PR	
Unit :		0.000001 times, which is 1 / (10 <sup>6</sup> )	
Range :		-2147.000000 ~ +2147.000000	
Data Size :		32-bit	
Format :		DEC	
Example :		1100000 = 1.1 times	

Related Section: -

Settings : (It will be provided after firmware version V1.017)

This parameter is used to magnify or minify the E-Cam table without changing its setting value.

For example, the data in the table is 0,10,20,30,40,20, magnification x 2.000000 equals to the data in the table: 0,20,40,60,80,40, magnification x 1.000000.

Enable the operation of E-Cam by using the same pulse frequency of the master axis. Magnify the magnification will enlarge the route of E-Cam operation. The speed will be magnified as well.



**NOTE**

This parameter can be set anytime, but will be effective only when pre-engaged → engaged.

P5-20	AC0	Acceleration/Deceleration Time (Number #0)	Address: 0528H 0529H
Operational Interface :		Panel / Software	Communication
Default :		200	
Control Mode :		PR	
Unit :		ms	
Range :		1 ~ 65500	
Data Size :		16-bit	
Format :		Decimal	

Related Section: 7.10

Settings : The setting time of acceleration/deceleration in PR mode, which is the time it needs when accelerating from 0 to 3000r/min

P5-21	AC1	Acceleration/Deceleration Time (Number #1)	Address: 052AH 052BH
Operational Interface :		Panel / Software	Communication
Default :		300	
Control Mode :		PR	
Unit :		ms	
Range :		1 ~ 65500	
Data Size :		16-bit	
Format :		Decimal	
Settings : Please refer to P5-20 for the setting of acceleration/deceleration time in PR mode.			

P5-22	AC2	Acceleration/Deceleration Time (Number #2)	Address: 052CH 052DH
Operational Interface :		Panel / Software	Communication
Default :		500	
Control Mode :		PR	
Unit :		ms	
Range :		1 ~ 65500	
Data Size :		16-bit	
Format :		Decimal	
Settings : Please refer to P5-20 for the setting of acceleration/deceleration time in PR mode.			

P5-23	AC3	Acceleration/Deceleration Time (Number #3)	Address: 052EH 052FH
Operational Interface :		Panel / Software	Communication
Default :		600	
Control Mode :		PR	
Unit :		ms	

Range :	1 ~ 65500
Data Size :	16-bit
Format :	Decimal
Settings :	Please refer to P5-20 for the setting of acceleration/deceleration time in PR mode.

<b>P5-24</b>	<b>AC4</b>	<b>Acceleration/Deceleration Time (Number #4)</b>	<b>Address: 0530H 0531H</b>
	Operational Interface :	Panel / Software      Communication	Related Section: 7.10
	Default :	800	
	Control Mode :	PR	
	Unit :	ms	
	Range :	1 ~ 65500	
	Data Size :	16-bit	
	Format :	Decimal	
Settings :	Please refer to P5-20 for the setting of acceleration/deceleration time in PR mode.		

<b>P5-25</b>	<b>AC5</b>	<b>Acceleration/Deceleration Time (Number #5)</b>	<b>Address: 0532H 0533H</b>
	Operational Interface :	Panel / Software      Communication	Related Section: 7.10
	Default :	900	
	Control Mode :	PR	
	Unit :	ms	
	Range :	1 ~ 65500	
	Data Size :	16-bit	
	Format :	Decimal	
Settings :	Please refer to P5-20 for the setting of acceleration/deceleration time in PR mode.		

P5-26	AC6	Acceleration/Deceleration Time (Number #6)	Address: 0534H 0535H
Operational Interface :		Panel / Software	Related Section: 7.10
		Communication	
Default :		1000	
Control Mode :		PR	
Unit :		ms	
Range :		1 ~ 65500	
Data Size :		16-bit	
Format :		Decimal	
Settings : Please refer to P5-20 for the setting of acceleration/deceleration time in PR mode.			

P5-27	AC7	Acceleration/Deceleration Time (Number #7)	Address: 0536H 0537H
Operational Interface :		Panel / Software	Related Section: 7.10
		Communication	
Default :		1200	
Control Mode :		PR	
Unit :		ms	
Range :		1 ~ 65500	
Data Size :		16-bit	
Format :		Decimal	
Settings : Please refer to P5-20 for the setting of acceleration/deceleration time in PR mode.			

P5-28	AC8	Acceleration/Deceleration Time (Number #8)	Address: 0538H 0539H
Operational Interface :		Panel / Software	Related Section: 7.10
		Communication	
Default :		1500	
Control Mode :		PR	
Unit :		ms	



Range :	1 ~ 65500
Data Size :	16-bit
Format :	Decimal
Settings :	Please refer to P5-20 for the setting of acceleration/deceleration time in PR mode.

<b>P5-29</b>	<b>AC9</b>	<b>Acceleration/Deceleration Time (Number #9)</b>	<b>Address: 053AH 053BH</b>
	Operational Interface :	Panel / Software      Communication	Related Section: 7.10
	Default :	2000	
	Control Mode :	PR	
	Unit :	ms	
	Range :	1 ~ 65500	
	Data Size :	16-bit	
	Format :	Decimal	
	Settings :	Please refer to P5-20 for the setting of acceleration/deceleration time in PR mode.	

<b>P5-30</b>	<b>AC10</b>	<b>Acceleration/Deceleration Time (Number #10)</b>	<b>Address: 053CH 053DH</b>
	Operational Interface :	Panel / Software      Communication	Related Section: 7.10
	Default :	2500	
	Control Mode :	PR	
	Unit :	ms	
	Range :	1 ~ 65500	
	Data Size :	16-bit	
	Format :	Decimal	
	Settings :	Please refer to P5-20 for the setting of acceleration/deceleration time in PR mode.	

P5-31	AC11	Acceleration/Deceleration Time (Number #11)	Address: 053EH 053FH
Operational Interface :		Panel / Software	Communication
Default :		3000	
Control Mode :		PR	
Unit :		ms	
Range :		1 ~ 65500	
Data Size :		16-bit	
Format :		Decimal	
Settings : Please refer to P5-20 for the setting of acceleration/deceleration time in PR mode.			

P5-32	AC12	Acceleration/Deceleration Time (Number #12)	Address: 0540H 0541H
Operational Interface :		Panel / Software	Communication
Default :		5000	
Control Mode :		PR	
Unit :		ms	
Range :		1 ~ 65500	
Data Size :		16-bit	
Format :		Decimal	
Settings : Please refer to P5-20 for the setting of acceleration/deceleration time in PR mode.			

P5-33	AC13	Acceleration/Deceleration Time (Number #13)	Address: 0542H 0543H
Operational Interface :		Panel / Software	Communication
Default :		8000	
Control Mode :		PR	
Unit :		ms	

Range :	1 ~ 65500
Data Size :	16-bit
Format :	Decimal
Settings :	Please refer to P5-20 for the setting of acceleration/deceleration time in PR mode.

<b>P5-34</b>	<b>AC14</b>	<b>Acceleration/Deceleration Time (Number #14)</b>	<b>Address: 0544H 0545H</b>
	Operational Interface :	Panel / Software      Communication	Related Section: 7.10
	Default :	50	
	Control Mode :	PR	
	Unit :	ms	
	Range :	1 ~ 1500	
	Data Size :	16-bit	
	Format :	Decimal	
	Settings :	The default value of this parameter is smaller (short deceleration time) and it is used for deceleration time setting of auto protection.	

<b>P5-35</b>	<b>AC15</b>	<b>Acceleration/Deceleration Time (Number #15)</b>	<b>Address: 0546H 0547H</b>
	Operational Interface :	Panel / Software      Communication	Related Section: 7.10
	Default :	30	
	Control Mode :	PR	
	Unit :	ms	
	Range :	1 ~ 1200	
	Data Size :	16-bit	
	Format :	Decimal	
	Settings :	The default value of this parameter is smaller (short deceleration time) and it is used for short deceleration time and stops promptly of auto protection.	

P5-36	CAST	CAPTURE - Start Address of Data Array	Address: 0548H 0549H
Operational Interface :		Panel / Software	Communication
Default :		0	
Control Mode :		ALL	
Unit :		-	
Range :		0 ~ (value set by P5-10 minus 1)	
Data Size :		16-bit	
Format :		Decimal	
Settings : The first data CAPTURE obtained should be saved in the address of data array.			



**NOTE** It is writable only when COMPARE stops (please refer to P5-39)

P5-37	CAAX	CAPTURE - Axis Position CNT	Address: 054AH 054BH
Operational Interface :		Panel / Software	Communication
Default :		0	
Control Mode :		ALL	
Unit :		-	
Range :		-2147483648 ~ +2147483647	
Data Size :		32-bit	
Format :		Decimal	
Settings : Shows the axis position of CAPTURE pulse source			



**NOTE** 1 ) It is writable only when COMPARE stops (please refer to P5-39)

2 ) If the source is the main encoder, this parameter is write-protected and the content is the feedback position of the motor (monitoring variable 00h).

P5-38	CANO	CAPTURE - The Number of Capturing Times	Address: 054CH 054DH
Operational Interface :		Panel / Software	Related Section: 7.11.1
		Communication	
Default :		1	
Control Mode :		ALL	
Unit :		-	
Range :		1 ~ (the value set by P5-10 minus the value set by P5-36)	
Data Size :		16-bit	
Format :		Decimal	
Settings : When CAP stops, it means the number of data that expect to capture (readable and writable)			
When CAP activates, it means the number of data that has not been captured (read-only); Every time, when it captures one data, the value of P5-38 will minus one. When the value is 0, it means the capturing is completed.			

**NOTE**

1. The number of data which is used by COMPARE, CAPTURE and E-Cam cannot exceed 800.
2. A2L does not support E-Cam function.

P5-39	CACT	CAPTURE - Activate CAP Control	Address: 054EH 054FH
Operational Interface :		Panel / Software	Related Section: 7.11.1
		Communication	
Default :		0x2010	
Control Mode :		ALL	
Unit :		-	
Range :		0x0000 ~ 0xF13F	
Data Size :		16-bit	
Format :		Hexadecimal	

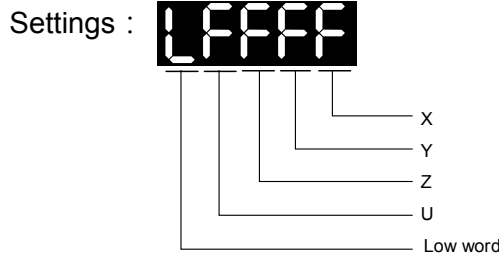

X: See the following table

Y: 0 - CAPTURE is not working

1 - AUX ENC (linear scale) is set as the source

2 - PULSE Cmd

3 - Main ENC (main encoder)

When the source of CMP is CAP axis, the source Y of CAP cannot be changed.

Z: 0 - NO, 1 - NC

U: trigger the minimum interval (Unit: ms)

bit	3	2	1	0
X function	Execute PR when finishing capturing	After capturing the first data, CMP is activated.	Reset the position of the first data	Activate CAP
Description	Execute PR # 50 after finishing CAP	It is invalid when CMP is activated.	After capturing the first data, reset the position coordinate	Starts to capture when it is set to 1. After finishing capturing, this bit becomes 0 automatically

bit 0: When the value set by P5-38 is bigger than 0, set bit 0 to 1 will activate CAP function and DO.CAP\_OK is OFF. Every time, when a data is captured, the value of P5-38 will minus one. When the P5-38 is 0, it means the capture function is completed, DO.CAP\_OK is ON and bit 0 will be reset to 0 automatically. If P5-38 equals to 0, set bit 0 to 1 will not activate CAP function. DO.CAP\_OK is OFF and bit 0 will automatically be set to 0. If CAP function is activated, it cannot set 1 to bit 0. It only can be written 0 to disable CAP function.

bit 1: If this bit is 1, when capturing the first data, the current position of CAP axis will be set to the value of P5-76.

bit 2: If this bit is 1, when capturing the first data, CMP will be activated. (When bit 0 of P5-59 is set to 1 and P5-58 is set to the previous value.) If CMP has been activated, then this function is invalid.

bit 3: If this bit is 1, as soon as the CAP finished, PR procedure #50 will be triggered automatically.

P5-40	DLY0	Delay Time After Position Completed (Number #0)	Address: 0550H 0551H
Operational Interface :		Panel / Software	Related Section: 7.10
		Communication	
Default :		0	
Control Mode :		PR	
Unit :		ms	
Range :		0 ~ 32767	
Data Size :		16-bit	
Format :		Decimal	
Settings : The 1 <sup>st</sup> Delay Time of PR mode			

P5-41	DLY1	Delay Time After Position Completed (Number #1)	Address: 0552H 0553H
Operational Interface :		Panel / Software	Related Section: 7.10
		Communication	
Default :		100	
Control Mode :		PR	
Unit :		ms	
Range :		0 ~ 32767	
Data Size :		16-bit	
Format :		Decimal	
Settings : The 2 <sup>nd</sup> Delay Time of PR mode			

P5-42	DLY2	Delay Time After Position Completed (Number #2)	Address: 0554H 0555H
Operational Interface :		Panel / Software	Related Section: 7.10
		Communication	
Default :		200	
Control Mode :		PR	
Unit :		ms	
Range :		0 ~ 32767	
Data Size :		16-bit	
Format :		Decimal	
Settings : The 3 <sup>rd</sup> Delay Time of PR mode			

P5-43	DLY3	Delay Time After Position Completed (Number #3)	Address: 0556H 0557H
Operational Interface :		Panel / Software	Related Section: 7.10
		Communication	
Default :		400	
Control Mode :		PR	
Unit :		ms	
Range :		0 ~ 32767	
Data Size :		16-bit	
Format :		Decimal	
Settings : The 4 <sup>th</sup> Delay Time of PR mode			

P5-44	DLY4	Delay Time After Position Completed (Number #4)	Address: 0558H 0559H
Operational Interface :		Panel / Software	Related Section: 7.10
		Communication	
Default :		500	
Control Mode :		PR	
Unit :		ms	



Range :	0 ~ 32767
Data Size :	16-bit
Format :	Decimal
Settings :	The 5 <sup>th</sup> Delay Time of PR mode

<b>P5-45</b>	<b>DLY5</b>	<b>Delay Time After Position Completed (Number #5)</b>	<b>Address: 055AH 055BH</b>
	Operational Interface :	Panel / Software      Communication	Related Section: 7.10
	Default :	800	
	Control Mode :	PR	
	Unit :	ms	
	Range :	0 ~ 32767	
	Data Size :	16-bit	
	Format :	Decimal	
	Settings :	The 6 <sup>th</sup> Delay Time of PR mode	

<b>P5-46</b>	<b>DLY6</b>	<b>Delay Time After Position Completed (Number #6)</b>	<b>Address: 055CH 055DH</b>
	Operational Interface :	Panel / Software      Communication	Related Section: 7.10
	Default :	1000	
	Control Mode :	PR	
	Unit :	ms	
	Range :	0 ~ 32767	
	Data Size :	16-bit	
	Format :	Decimal	
	Settings :	The 7 <sup>th</sup> Delay Time of PR mode	

P5-47	DLY7	Delay Time After Position Completed (Number #7)	Address: 055EH 055FH
Operational Interface :		Panel / Software	Related Section: 7.10
		Communication	
Default :		1500	
Control Mode :		PR	
Unit :		ms	
Range :		0 ~ 32767	
Data Size :		16-bit	
Format :		Decimal	

Settings : The 8<sup>th</sup> Delay Time of PR mode

P5-48	DLY8	Delay Time After Position Completed (Number #8)	Address: 0560H 0561H
Operational Interface :		Panel / Software	Related Section: 7.10
		Communication	
Default :		2000	
Control Mode :		PR	
Unit :		ms	
Range :		0 ~ 32767	
Data Size :		16-bit	
Format :		Decimal	

Settings : The 9<sup>th</sup> Delay Time of PR mode

P5-49	DLY9	Delay Time After Position Completed (Number #9)	Address: 0562H 0563H
Operational Interface :		Panel / Software	Related Section: 7.10
		Communication	
Default :		2500	
Control Mode :		PR	
Unit :		ms	

Range :	0 ~ 32767
Data Size :	16-bit
Format :	Decimal
Settings :	The 10 <sup>th</sup> Delay Time of PR mode

<b>P5-50</b>	<b>DLY10</b>	<b>Delay Time After Position Completed (Number #10)</b>	<b>Address: 0564H 0565H</b>
	Operational Interface :	Panel / Software      Communication	Related Section: 7.10
	Default :	3000	
	Control Mode :	PR	
	Unit :	ms	
	Range :	0 ~ 32767	
	Data Size :	16-bit	
	Format :	Decimal	
	Settings :	The 11 <sup>th</sup> Delay Time of PR mode	

<b>P5-51</b>	<b>DLY11</b>	<b>Delay Time After Position Completed (Number #11)</b>	<b>Address: 0566H 0567H</b>
	Operational Interface :	Panel / Software      Communication	Related Section: 7.10
	Default :	3500	
	Control Mode :	PR	
	Unit :	ms	
	Range :	0 ~ 32767	
	Data Size :	16-bit	
	Format :	Decimal	
	Settings :	The 12 <sup>th</sup> Delay Time of PR mode	

P5-52	DLY12	Delay Time After Position Completed (Number #12)	Address: 0568H 0569H
Operational Interface :		Panel / Software	Related Section: 7.10
		Communication	
Default :		4000	
Control Mode :		PR	
Unit :		ms	
Range :		0 ~ 32767	
Data Size :		16-bit	
Format :		Decimal	
Settings : The 13 <sup>th</sup> Delay Time of PR mode			

P5-53	DLY13	Delay Time After Position Completed (Number #13)	Address: 056AH 056BH
Operational Interface :		Panel / Software	Related Section: 7.10
		Communication	
Default :		4500	
Control Mode :		PR	
Unit :		ms	
Range :		0 ~ 32767	
Data Size :		16-bit	
Format :		Decimal	
Settings : The 14 <sup>th</sup> Delay Time of PR mode			

P5-54	DLY14	Delay Time After Position Completed (Number #14)	Address: 056CH 056DH
Operational Interface :		Panel / Software	Related Section: 7.10
		Communication	
Default :		5000	
Control Mode :		PR	
Unit :		ms	

Range : 0 ~ 32767
Data Size : 16-bit
Format : Decimal
Settings : The 15 <sup>th</sup> Delay Time of PR mode

<b>P5-55</b>	<b>DLY15</b>	<b>Delay Time After Position Completed (Number #15)</b>	<b>Address: 056EH 056FH</b>
	Operational Interface :	Panel / Software	Communication
	Default :	5500	
	Control Mode :	PR	
	Unit :	ms	
	Range :	0 ~ 32767	
	Data Size :	16-bit	
	Format :	Decimal	
	Settings :	The 16 <sup>th</sup> Delay Time of PR mode	

<b>P5-56</b>	<b>CMST</b>	<b>COMPARE - Start Address of Data Array</b>	<b>Address: 0570H 0571H</b>
	Operational Interface :	Panel / Software	Communication
	Default :	0	
	Control Mode :	ALL	
	Unit :	-	
	Range :	0 ~ (The value of P5-10 minus 1)	
	Data Size :	16-bit	
	Format :	Decimal	
	Settings :	The first COMPARE data is saved in the address of data array.	



**NOTE** It is writable only when COMPARE stops (please refer to P5-59)

P5-57	CMAX	COMPARE - Axis Position	Address: 0572H 0573H
Operational Interface :	Panel / Software	Communication	Related Section: 7.11.2
Default :	0		
Control Mode :	ALL		
Unit :	-		
Range :	-2147483648 ~ +2147483647		
Data Size :	32-bit		
Format :	Decimal		
Settings :	The axis position of COMPARE pulse source is displayed here. It is writable only when COMPARE stops (please refer to P5-59)		

**NOTE**

1 ) It is write-protected when the source is Capture axis.

2 ) When the source is the main encoder, P5-57 is also write-protected. The pulse revolution is determined by parameter P1-46. When P5-59.Y is set to the main encoder, this parameter is set to the motor feedback position (monitoring variable 00h). If this parameter is not the same as the motor feedback position due to homing or reset by CAP function, the user can set P5-59.Y = 0 and then P5-59.Y = 3. In this way, this parameter will be reset to the motor feedback position.

P5-58	CMNO	COMPARE - Compare Amount	Address: 0574H 0575H
Operational Interface :	Panel / Software	Communication	Related Section: 7.11.2
Default :	1		
Control Mode :	ALL		
Unit :	-		
Range :	1 ~ (the value set by P5-10 minus the value set by P5-56)		
Data Size :	16-bit		
Format :	Decimal		
Settings :			

Settings : When COMPARE stops, it means the number of data that expect to compare (readable and writable)

When COMPARE activates, it means the number of data that has not been compared (read-only); Every time, when it compares one data, the value of P5-38 will minus one. When the value is 0, it means the comparing is completed.

<b>P5-59</b>	<b>CMCT</b>	<b>COMPARE - Activate CMP Control</b>	<b>Address: 0576H 0577H</b>
	Operational Interface :	Panel / Software	Communication
	Default :	00640010h	
	Control Mode :	ALL	
	Unit :	-	
	Range :	00010000h ~ 0x0FFF313F	
	Data Size :	32-bit	
	Format :	Hexadecimal	

Settings :

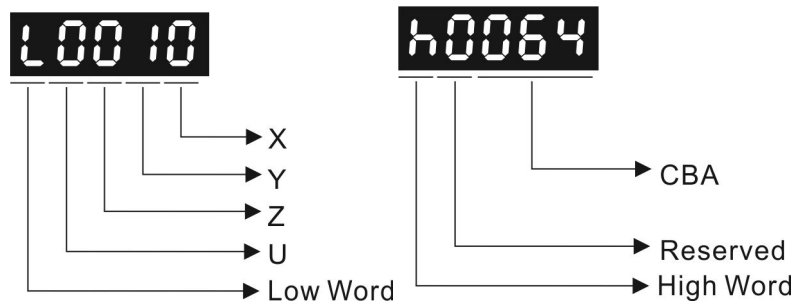

X: See the following table.

Y: 0 - When selecting CAPTURE AXES, the source of CAP cannot be changed.

- 1 - AUX ENC (linear scale) is set as the source
- 2 - PULSE Cmd
- 3 - Main ENC (main encoder)

Z: 0 - NO, 1 - NC outputs the polarity

U: See table U below:

bit	15	14	13	12
U function	-	-	-	Trigger PR
Description	-	-	-	When this bit is set to 1, PR#45 will be triggered after the last compare is completed. It is provided in V1.038 sub09 (or the later version)

CBA: Output the pulse length; Unit: 1ms

bit	3	2	1	0
X function	After finishing comparing, the counter returns to 0.	When finishing comparing, CAP is activated.	Cycle mode	CMP is activated
Description	As soon as the last data is compared, P5-57 is set to 0.	It is invalid when CAP is activated.	Never end	Starts to compare when this bit is set to 1. It returns to 0 when finishing comparing.

bit 0: When the value of P5-58 is more than 0, set bit to 1 will activate CMP. When comparing one data, the value of P5-58 will minus 1. When P5-58 is set to 0, the comparing is completed and returns to 0. If P5-58 is 0, set bit 0 to 1 will not do any comparing and return to 0 automatically. If bit 0 has already been set to 1, it is not allowed to write 1 as the new value into the parameter. But it is ok to write 0 to disable CMP.

bit 1: If this bit is 1, P5-58 will be reset after comparing the last data. Then, start from the first data again. The cycle will never end and bit 0 is always 1.

bit 2: If this bit is 1, CAP will be activated after comparing the last data. (Set bit 0 of P5-39 to 1 and reset P5-38 to the previous value) If CAP has already been activated, this function is invalid.

bit 3: If this bit is 1, set the counter (P5-57) to 0 after comparing the last data. For example, if the comparing data is set to 3000 (one data in total), the default value of the counter (P5-57) is 0. It is expected to input 4000 pulse. When it reaches the 3000<sup>th</sup> pulse, the CMP is completed and P5-57 returns to 0. When the pulse reaches 4000, P5-57=1000. (No accumulative error)



P5-60	POV0	Target Speed Setting #0	Address: 0578H 0579H
	Operational Interface :	Panel / Software	Communication
	Default :	20.0	200
	Control Mode :	PR	
	Unit :	1 r/min	0.1 r/min
	Range :	0.1 ~ 6000.0	1 ~ 60000
	Data Size :	16-bit	
	Format :	Decimal	
	Example :	15 = 15 r/min	150 = 15 r/min
	Settings :	The 1 <sup>st</sup> target speed of PR mode	

P5-61	POV1	Target Speed Setting #1	Address: 057AH 057BH
	Operational Interface :	Panel / Software	Communication
	Default :	50.0	500
	Control Mode :	PR	
	Unit :	1 r/min	0.1 r/min
	Range :	0.1 ~ 6000.0	1 ~ 60000
	Data Size :	16-bit	
	Format :	Decimal	
	Example :	1 = 1 r/min	10 = 1 r/min
	Settings :	The 2 <sup>nd</sup> target speed of PR mode	

P5-62	POV2	Target Speed Setting #2	Address: 057CH 057DH
	Operational Interface :	Panel / Software	Communication
	Default :	100.0	1000
	Control Mode :	PR	
	Unit :	1 r/min	0.1 r/min
	Range :	0.1 ~ 6000.0	1 ~ 60000
	Data Size :	16-bit	
	Format :	Decimal	
	Example :	1 = 1 r/min	10 = 1r/min
	Settings : The 3 <sup>rd</sup> target speed of PR mode		
	Related Section: 7.10		

P5-63	POV3	Target Speed Setting #3	Address: 057EH 057FH
	Operational Interface :	Panel / Software	Communication
	Default :	200.0	2000
	Control Mode :	PR	
	Unit :	1 r/min	0.1 r/min
	Range :	0.1 ~ 6000.0	1 ~ 60000
	Data Size :	16-bit	
	Format :	Decimal	
	Example :	1 = 1 r/min	10 = 1r/min
	Settings : The 4 <sup>th</sup> target speed of PR mode		
	Related Section: 7.10		

P5-64	POV4	Target Speed Setting #4	Address: 0580H 0581H
	Operational Interface :	Panel / Software	Communication
	Default :	300.0	3000
	Control Mode :	PR	
	Unit :	1 r/min	0.1 r/min
	Range :	0.1 ~ 6000.0	1 ~ 60000
	Data Size :	16-bit	
	Format :	Decimal	
	Example :	1 = 1 r/min	10 = 1r/min
	Settings :	The 5 <sup>th</sup> target speed of PR mode	
			Related Section: 7.10

P5-65	POV5	Target Speed Setting #5	Address: 0582H 0583H
	Operational Interface :	Panel / Software	Communication
	Default :	500.0	5000
	Control Mode :	PR	
	Unit :	1 r/min	0.1 r/min
	Range :	0.1 ~ 6000.0	1 ~ 60000
	Data Size :	16-bit	
	Format :	Decimal	
	Example :	1 = 1 r/min	10 = 1r/min
	Settings :	The 6 <sup>th</sup> target speed of PR mode	
			Related Section: 7.10

P5-66	POV6	Target Speed Setting #6	Address: 0584H 0585H
Operational Interface :	Panel / Software	Communication	Related Section: 7.10
Default :	600.0	6000	
Control Mode :	PR		
Unit :	1 r/min	0.1 r/min	
Range :	0.1 ~ 6000.0	1 ~ 60000	
Data Size :	16-bit		
Format :	Decimal		
Example :	1 = 1 r/min	10 = 1r/min	
Settings : The 7 <sup>th</sup> target speed of PR mode			

P5-67	POV7	Target Speed Setting #7	Address: 0586H 0587H
Operational Interface :	Panel / Software	Communication	Related Section: 7.10
Default :	800.0	8000	
Control Mode :	PR		
Unit :	1 r/min	0.1 r/min	
Range :	0.1 ~ 6000.0	1 ~ 60000	
Data Size :	16-bit		
Format :	Decimal		
Example :	1 = 1 r/min	10 = 1r/min	
Settings : The 8 <sup>th</sup> target speed of PR mode			

P5-68	POV8	Target Speed Setting #8	Address: 0588H 0589H
	Operational Interface :	Panel / Software	Communication
	Default :	1000.0	10000
	Control Mode :	PR	
	Unit :	1 r/min	0.1 r/min
	Range :	0.1 ~ 6000.0	1 ~ 60000
	Data Size :	16-bit	
	Format :	Decimal	
	Example :	1 = 1 r/min	10 = 1r/min
	Settings :	The 9 <sup>th</sup> target speed of PR mode	

P5-69	POV9	Target Speed Setting #9	Address: 058AH 058BH
	Operational Interface :	Panel / Software	Communication
	Default :	1300.0	13000
	Control Mode :	PR	
	Unit :	1 r/min	0.1 r/min
	Range :	0.1 ~ 6000.0	1 ~ 60000
	Data Size :	16-bit	
	Format :	Decimal	
	Example :	1 = 1 r/min	10 = 1r/min
	Settings :	The 10 <sup>th</sup> target speed of PR mode	

P5-70	POV10	Target Speed Setting #10	Address: 058CH 058DH
	Operational Interface :	Panel / Software	Communication
	Default :	1500.0	15000
	Control Mode :	PR	
	Unit :	1 r/min	0.1 r/min
	Range :	0.1 ~ 6000.0	1 ~ 60000
	Data Size :	16-bit	
	Format :	Decimal	
	Example :	1 = 1 r/min	10 = 1r/min
	Settings : The 11 <sup>th</sup> target speed of PR mode		

P5-71	POV11	Target Speed Setting #11	Address: 058EH 058FH
	Operational Interface :	Panel / Software	Communication
	Default :	1800.0	18000
	Control Mode :	PR	
	Unit :	1 r/min	0.1 r/min
	Range :	0.1 ~ 6000.0	1 ~ 60000
	Data Size :	16-bit	
	Format :	Decimal	
	Example :	1 = 1 r/min	10 = 1r/min
	Settings : The 12 <sup>th</sup> target speed of PR mode		

P5-72	POV12	Target Speed Setting #12	Address: 0590H 0591H
	Operational Interface :	Panel / Software	Communication
	Default :	2000.0	20000
	Control Mode :	PR	
	Unit :	1 r/min	0.1 r/min
	Range :	0.1 ~ 6000.0	11 ~ 600001
	Data Size :	16-bit	
	Format :	Decimal	
	Example :	1 = 1 r/min	10 = 1r/min
	Settings : The 13 <sup>th</sup> target speed of PR mode		

P5-73	POV13	Target Speed Setting #13	Address: 0592H 0593H
	Operational Interface :	Panel / Software	Communication
	Default :	2300.0	23000
	Control Mode :	PR	
	Unit :	1 r/min	0.1 r/min
	Range :	0.1 ~ 6000.0	1 ~ 60000
	Data Size :	16-bit	
	Format :	Decimal	
	Example :	1 = 1 r/min	10 = 1r/min
	Settings : The 14 <sup>th</sup> target speed of PR mode		

P5-74	POV14	Target Speed Setting #14	Address: 0594H 0595H
Operational Interface :		Panel / Software	Communication
Default :		2500.0	25000
Control Mode :		PR	
Unit :		1 r/min	0.1 r/min
Range :		0.1 ~ 6000.0	1 ~ 60000
Data Size :		16-bit	
Format :		Decimal	
Example :		1 = 1 r/min	10 = 1r/min
Settings : The 15 <sup>th</sup> target speed of PR mode			

P5-75	POV15	Target Speed Setting #15	Address: 0596H 0597H
Operational Interface :		Panel / Software	Communication
Default :		3000.0	30000
Control Mode :		PR	
Unit :		1 r/min	0.1 r/min
Range :		0.1 ~ 6000.0	1 ~ 60000
Data Size :		32-bit	
Format :		Decimal	
Example :		1 = 1 r/min	10 = 1r/min
Settings : The 16 <sup>th</sup> target speed of PR mode			



P5-76★	CPRS	CAPTURE - First Position Reset Data	Address: 0598H 0599H
Operational Interface :		Panel / Software	Communication
Default :		0	
Control Mode :		ALL	
Unit :		-	
Range :		-1073741824 ~ +1073741823	
Data Size :		32-bit	
Format :		Decimal	
Settings : Please refer to the description of P5-39 X 1			
Related Section: 7.10			

P5-77■	CSAX	The Position of Synchronous Capture Axis (CAP SYNC AXES)	Address: 059AH 059BH
Operational Interface :		Panel / Software	Communication
Default :		0	
Control Mode :		ALL	
Unit :		-	
Range :		-2147483648 ~ +2147483647	
Data Size :		32-bit	
Format :		Decimal	
Settings : The position of this axis will synchronize with CAP signal. That is to say, when activating CAP every two times, the motor moving distance of this axis is the value of P5-78. (There is no accumulative error and only in single-way operation) The synchronous capture axis can be the source of Master.			
Related Section: -			

P5-78	CSDS	The Interval Pulse Number between Each Synchronous Capture Axis	Address: 059CH 059DH
	Operational Interface :	Panel / Software	Communication
	Default :	100	
	Control Mode :	ALL	
	Unit :	Pulse	
	Range :	10 ~ +100000000	
	Data Size :	32-bit	
	Format :	Decimal	
	Settings :	It is the moving distance of synchronous capture axis between two CAP actions. The new value can be written into the parameter not until CAP is disabled (P5-39, X0=0).	
			Related Section: -

P5-79	CSDS	Error Pulse Number of Synchronous Capture Axis	Address: 059EH 059FH
	Operational Interface :	Panel / Software	Communication
	Default :	0	
	Control Mode :	ALL	
	Unit :	Pulse unit of capture axis	
	Range :	-2147483648 ~ +2147483647	
	Data Size :	32-bit	
	Format :	Decimal	
			Related Section: -

Settings : When synchronous capture axis is operating, the synchronous error should be 0. This parameter shows this error value. The followings are its concept:

$$\begin{aligned} \text{Synchronous Error} &= \text{Output value of synchronous axis} - \text{Setting value of synchronous axis} \\ &= \text{the accumulative amount of P5-77} - (\text{P5-78} \times \text{Capturing number of times}) \end{aligned}$$

When capturing the data, the synchronous axis works normally. This parameter updates once.

This parameter can be written into as well. It indicates the offset of synchronous master. When the synchronous capture axis is regarded as the master of flying shear, modify this parameter can deviate the cutting position to the left/right.

 **NOTE** A2L does not support E-Cam function.

<b>P5-80</b>	<b>CSDS</b>	<b>Max. Correction Rate of Synchronous Capture Axis</b>		<b>Address: 05A0H 05A1H</b>
	Operational Interface :	Panel / Software	Communication	Related Section: -
	Default :	10		
	Control Mode :	ALL		
	Unit :	%		
	Range :	0 ~ 90		
	Data Size :	16-bit		
	Format :	Decimal		

Settings : This parameter limits the percentage (%) of synchronous adjustment.  
Correction rate

$$\begin{aligned} &= \text{pulse number output by synchronous axis} \\ &\quad / \text{pulse number input by synchronous axis} (100 - P5 - 80)\% < \textit{correctionrate} < (100 + P5 - 80)\% \end{aligned}$$

The bigger correction rate, the faster the synchronous error becomes 0. However, the speed changing will be more severe.

The smaller correction rate, the slower the synchronous error becomes 0. However, the speed changing will be smoother.

In the application of flying shear, after adjusting the synchronous error, P5-79: the bigger parameter value will reduce the time the slave axis goes to the desired position. However, the speed is not synchronized.

 **NOTE** A2L does not support E-Cam function.

P5-81	ECHD	E-CAM: Start Address of Data Array	Address: 05A2H 05A3H
Operational Interface :		Panel / Software	Communication
Default :		100	
Control Mode :		PR	
Unit :		-	
Range :		0 ~ (800 - P5-82)	
Data Size :		16-bit	
Format :		Decimal	

Related Section:  
7.11

Settings : The first data of E-Cam table is saved in the address of data array.



**NOTE**

1. Version V1.015 (before): This parameter cannot be modified when E-Cam is activated (P5-88, X = 1).
2. Version V1.015 (included or after): This parameter can be set anytime, but will be effective only when pre-engaged → engaged.
3. A2L does not support this function.

P5-82	ECMN	E-CAM: Area Number N (at least >=5)	Address: 05A4H 05A5H
Operational Interface :		Panel / Software	Communication
Default :		5	
Control Mode :		PR	
Unit :		-	
Range :		5 ~ 720, must < = (P5-10 - P5-81) And P5-82 x P5-84 < = 2147483647	
Data Size :		16-bit	
Format :		Decimal	

Related Section:  
7.11

Settings : It means the E-Cam curve is divided into N area, and the table should include N+1 data.



**NOTE**

1. This parameter can be wrote when E-Cam stops (Please refer to P5-88, X=0).
2. A2L does not support E-Cam function.

P5-83	ECMM	E-CAM: Master Gear Ratio Setting M	Address: 05A6H 05A7H
Operational Interface :		Panel / Software	Communication
Default :		1	
Control Mode :		PR	
Unit :		-	
Range :		1 ~ 32767	
Data Size :		16-bit	
Format :		Decimal	

Related Section:  
7.11

Settings : When receiving pulse number P of the Master, E-Cam will rotate M circle, which means the M cycle of the E-Cam table.



**NOTE**

1. This parameter can be wrote when E-Cam stops (Please refer to P5-88, X=0).
2. A2L does not support E-Cam function.

P5-84	ECMP	E-CAM: Master Gear Ratio Setting P	Address: 05A8H 05A9H
Operational Interface :		Panel / Software	Communication
Default :		3600	
Control Mode :		PR	
Unit :		-	
Range :		10 ~ 1073741823, and $P5-82 \times P5-83 \leq P5-84$ and $P5-82 \times P5-84 \leq 2147483647$	
Data Size :		32-bit	
Format :		Decimal	

Related Section:  
7.11

Settings : When receiving pulse number P of the Master, E-Cam will rotate M circle, which means the M cycle of the E-Cam table.



**NOTE**

1. This parameter can be wrote when E-Cam stops (Please refer to P5-88, X=0).
2. This parameter can be modified anytime, and has no limit that mentioned above.
3. A2L does not support E-Cam function.

P5-85	ECME	E-CAM: Number of Area	Address: 05AAH 05ABH
Operational Interface :		Panel / Software	Communication
Default :		0	
Control Mode :		PR	
Unit :		-	
Range :		0 ~ (P5-82 - 1)	
Data Size :		16-bit	
Format :		Decimal	
Settings : The area number of E-cam when E-cam engaged.			
 <b>NOTE</b> A2L does not support E-Cam function.			

P5-86	ECAX	E-CAM: Master Axis Position	Address: 05ACH 05ADH
Operational Interface :		Panel / Software	Communication
Default :		0	
Control Mode :		PR	
Unit :		-	
Range :		-2147483648 ~ +2147483647	
Data Size :		32-bit	
Format :		Decimal	
Settings : The position counter of the E-Cam Master			
 <b>NOTE</b> <ol style="list-style-type: none"> <li>1. This parameter can be wrote when E-Cam stops (Please refer to P5-88, X=0).</li> <li>2. A2L does not support E-Cam function.</li> </ol>			

P5-87	PLED	E-CAM: Lead Pulse	Address: 05AEH 05AFH
Operational Interface :		Panel / Software	Communication
Default :		0	
Control Mode :		PR	
Unit :		-	
Range :		-1073741824 ~ +1073741823	
Data Size :		32-bit	
Format :		Decimal	
Settings :		<p>When the engaging condition (P5-88.Z) of E-cam is satisfied, the pulse number from the master has to exceed the setting value of this parameter, so that E-cam is fully engaged.</p> <p>In other words, E-cam engages after neglecting the lead pulse specified by this parameter.</p> <p>If the symbol of this parameter is +, it means the received forward pulse is regarded as the lead pulse.</p> <p>If the symbol of this parameter is - , it means the received reverse pulse is regarded as the lead pulse.</p>	
		 <b>NOTE</b> A2L does not support E-Cam function.	

P5-88	ECON	E-CAM: Activate E-Cam Control	Address: 05B0H 05B1H
Operational Interface :		Panel / Software	Communication
Default :		00000000h	
Control Mode :		PR	
Unit :		-	
Range :		0 ~ 0x203FF257	
Data Size :		32-bit	
Format :		Hexadecimal	

Settings : The format of this parameter: (High word h) S0BA : (Low word L) UZYX

Definition of each column is as follows:

- X: E-Cam command

Description of each bit:

X3	-	-
X2	P5-19 is effective immediately	It is available after V1.038 sub48: 0: P5-19 is effective after the next engage. 1: P5-19 is effective immediately.
X1	E-Cam does not disengage when Servo OFF	It is available after 1.038 sub29: 0: E-Cam does not work 1: When E-Cam stops because of alarm or Servo Off, it can keep in engaged status. When re-servo on, E-cam can operate directly. It can return to the correct position by macro #D.
X0	E-Cam is enabled	0: E-Cam is disabled 1: E-Cam is enabled (E-CAM is enabled while other functions cannot be modified.)

- Y: Command source
  - 0: CAP axis
  - 1: AUX ENC
  - 2: Pulse Cmd
  - 3: PR command
  - 4: Time Axis (1ms)
  - 5: Synchronous Capture Axis (P5-77)
  - 6: Analog channel 1 (virtual axis, Unit: 1M pulse/s /10V)
- Z: Engaging Time (No multiple choice)
  - 0: Immediately
  - 1: DI.CAM ON
  - 2: Any one of the Capture



- U: Disengaging Condition (2, 4 and 6 cannot be selected at the same time)

U	Disengaged Condition	Action after disengaged
0	Never disengaged	-
1	DI.CAM is OFF	In STOP status
2	Master axis receives the pulse number which is set by P5-89 and stops immediately. (The symbol represents the direction)	In STOP status
6	(It is available after firmware version V1.009) Same as 2, the E-cam starts to decelerate when disengaging. It is suitable for the application of calling the next PR position command right after disengaged.	
4	(It is available after firmware version V1.009) Master axis exceeds the setting value of P5-89 (Sign indicates the direction)	Back to the pre-engage status The lead pulse is P5-92
8	When U = 1, 2 or 6: Disable E-Cam after it is disengaged.	Set X to 0
	When U = 4: To avoid jittering when it returns to lead status.	N/A

**NOTE**

The servo is Off, when ALM or forward/reverse limit occur or PR is doing homing procedure, it disengages (P5-88, X = 0)

- BA: When disengaging condition is satisfied (P5-88, U = 2, 4, 6), a PR 00~63 (hexadecimal; 00 means no action) will automatically be executed.
- S: Shows the engage status (Read-only, the setting is invalid)
  - 0: Stop
  - 1: Engage status
  - 2: Pre-engage status

P5-89	ECRD	E-CAM: Information of Disengaging Time	Address: 05B2H 05B3H
Operational Interface :		Panel / Software	Communication
Default :		0	
Control Mode :		PR	
Unit :		-	
Range :		-1073741824 ~ +1073741823	
Data Size :		32-bit	
Format :		Decimal	
Settings : (Please refer to the definition of P5-88 U setting value 2)			
 <b>NOTE</b> A2L does not support E-Cam function.			

P5-90	CMAP	E-CAM: AREA No. + The Point of DO ON	Address: 05B4H 05B5H
Operational Interface :		Panel / Software	Communication
Default :		0	
Control Mode :		PR	
Unit :		Degree (It was changed after firmware V1.009)	
Range :		0 ~ 360	
Data Size :		16-bit	
Format :		Decimal	
Settings : When E-cam is engaged, set the start angle of DO output (DO. CAM_AREA).			
 <b>NOTE</b> A2L does not support E-Cam function.			

P5-91	CMAN	E-CAM: AREA No. - The Point of DO OFF	Address: 05B6H 05B7H
Operational Interface :	Panel / Software	Communication	Related Section: 7.11
Default :	0		
Control Mode :	PR		
Unit :	Degree		
Range :	0 ~ 360		
Data Size :	16-bit		
Format :	Decimal		
Settings :	When E-cam is engaged, set the end angle of DO output (DO. CAM_AREA).		

P5-92	PLED	E-CAM: Pre-engaged Time of Each Cycle	Address: 05B8H 05B9H
Operational Interface :	Panel / Software	Communication	Related Section: 7.11
Default :	0		
Control Mode :	PR		
Unit :	-		
Range :	-2147483648 ~ +2147483647		
Data Size :	32-bit		
Format :	Decimal		
Settings :	<p>This parameter goes with the selection of P5-88, U=4 (E-cam will disengage if it exceeds the moving distance):</p> <p>After disengaging, it does not enter the Stop status but pre-engaged status. The lead pulse is determined by this parameter.</p> <p>The pulse number sent by the Master must exceed the setting value of this parameter so that E-cam will engage again.</p> <p>In other words, E-cam will engage not until the lead pulse is ignored.</p> <p>If the symbol of this parameter is + , it means the received positive pulse will be regarded as the lead pulse.</p> <p>If the symbol of this parameter is - , it means the received negative pulse will be regarded as the lead pulse.</p>		

<b>P5-93</b>	<b>CSDS</b>	<b>Motion Control Macro Command: Command Parameter # 4</b>	<b>Address: 05BAH 05BBH</b>
--------------	-------------	--	---------------------------------

Operational Interface :	Panel / Software	Communication	Related Section: -
-------------------------	------------------	---------------	--------------------

Default : 0

Control Mode : ALL

Unit : -

Range : -100000000 ~ +100000000

Data Size : 32-bit

Format : Decimal

Settings : Before issuing the macro command, the relevant parameters # 4 must be set in advance.

The function of the parameter is determined by the macro command. Not every macro command has its relevant parameters.

<b>P5-94</b>	<b>CSDS</b>	<b>Motion Control Macro Command: Command Parameter # 3</b>	<b>Address: 05BCH 05BDH</b>
--------------	-------------	--	---------------------------------

Operational Interface :	Panel / Software	Communication	Related Section: -
-------------------------	------------------	---------------	--------------------

Default : 0

Control Mode : ALL

Unit : -

Range : -2147483648 ~ +2147483647

Data Size : 32-bit

Format : Decimal

Settings : Before issuing the macro command, the relevant parameters # 3 must be set in advance.

The function of the parameter is determined by the macro command. Not every macro command has its relevant parameters.

P5-95	CSDS	Motion Control Macro Command: Command Parameter # 2	Address: 05BEH 05BFH
Operational Interface :		Panel / Software	Communication
Default :		0	
Control Mode :		ALL	
Unit :		-	
Range :		-2147483648 ~ +2147483647	
Data Size :		32-bit	
Format :		Decimal	
<p>Settings : Before issuing the macro command, the relevant parameters # 2 must be set in advance.</p> <p>The function of the parameter is determined by the macro command. Not every macro command has its relevant parameters.</p>			

P5-96	CSDS	Motion Control Macro Command: Command Parameter # 1	Address: 05C0H 05C1H
Operational Interface :		Panel / Software	Communication
Default :		0	
Control Mode :		ALL	
Unit :		-	
Range :		-2147483648 ~ +2147483647	
Data Size :		32-bit	
Format :		Decimal	
<p>Settings : Before issuing the macro command, the relevant parameters # 1 must be set in advance.</p> <p>The function of the parameter is determined by the macro command. Not every macro command has its relevant parameters.</p>			

<b>P5-97</b>	<b>CSDS</b>	<b>Motion Control Macro Command: Issue Command / Executing Result</b>	<b>Address: 05C2H 05C3H</b>
	Operational Interface :	Panel / Software	Communication
	Default :	0	
	Control Mode :	ALL	
	Unit :	-	
	Range :	0 ~ 0x99F	
	Data Size :	16-bit	
	Format :	Hexadecimal	

Related Section: -

**Settings :** Write-in: It is used to issue the macro command (0CBAh)  
 Read: It is used to examine the execution result of macro command (If success, the result will be sent back to 1CBAh).  
 If the command issues 0001, 1001h will be sent back when success; and Fxxxh when failed (depending on the command description).  
 If issuing the command that is not supported, the failure code F001h will be sent back.

The provided command code is as the followings.

The following macros are available from Version V1.027 (included):

Command code 0003h	Motion parameter protection: password setting, protection activation
Macro parameters	P5-93= Parameter write-protected level (0~1) (0 means no protection) P5-94= Protection level of data array (0~7) (-1 means no protection) P5-95= Set new password (1~16777215) P5-96= Confirm new password (1~16777215) Among them: For success setting, the setting of P5-95 must equal to P5-96 and the password must be set within the allowable range.
This function can be executed before activating the function of parameter protection. If the protection function is activated, when repeat execute this function, the failure code will be sent back.	
Failure code F031h	Protection function has been activated and cannot be set repeat.
Failure code F032h	Wrong password setting: P5-95 not equals to P5-96.
Failure code F033h	Password setting exceeds the allowable range (1~16777215).
Failure code F034h	The protection level, P5-94 exceeds the allowable range (-1~7).

Failure code F035h	The protection level, P5-94 exceeds the allowable range (0~1).
Success code 1003h	

The following macros are available from version V1.026 (included):

Command code 0004h	Motion parameter protection: unlock the protection
Macro parameters	P5-96= enter the password (1~16777215)
<p>This function can be executed when activating the function of parameter protection. If the protection function is unlocked, repeat execute this function will sent back the failure code.</p> <p>If entering the wrong password, failure code Ennn will be sent back. nnn means the rest decode number. It will be misused one number after one failure. When the number is 0, it will be locked for good.</p>	
Failure code F041h	Protection function is unlocked and it cannot repeat unlock.
Failure code F043h	The password setting exceed the allowable range (1~16777215)
Failure code F044h	<p>The number of times of entering wrong password exceeds the limit: Lock for good.</p> <p>Reset the parameter (P2-08=10) to unlock it is the only method. However, all parameter will return to the default value.</p>
Failure code Ennnh	<p>Incorrect password setting: Failed to unlock.</p> <p>nnn: the rest decode number. It will be minuses one number after one failure. When the number is 0, it will be locked for good.</p>
Success code 1004h	

The following macros are available from version 1.024 (included):

Command code 0006h	Build up E-Cam table: flying shear, including synchronous area (7 areas)
General parameters	<p>P5-81= Address of table (Data array)</p> <p>P5-82 = 7 (This macro is fixed to 7 areas)</p> <p>P1-44, P1-45 = E-gear ratio (it has to be setup in advance)</p>
Macro parameters	<p>P5-94 = A (Deceleration ratio: numerator) x C (Number of cutter)</p> <p>P5-95= B (Deceleration ratio: denominator)</p> <p>P5-96= 1000000 x R x V</p> <p>Among them:</p> <p><math>R</math> (cutting ratio) = <math>L</math> (cutting length) / <math>l</math> (Girth of cutter)</p> <p>Allowable cutting ratio: (0.3 ~ 2.5) times</p> <p><math>V</math> (Speed factor) = target cutting speed / speed of delivered product</p>

	<p>V=1.0: When cutting, the speed of cutter is the same as the product</p> <p>V=1.1: When cutting, the speed of cutter is 10% faster than the product</p> <p>V=0.9: When cutting, the speed of cutter is 10% slower than the product</p>
<p>This macro will calculate the data of E-Cam table according to the above mentioned parameters, and store in data array which designated by P5-81. Parameters listed above are related to E-Cam table calculation. Please correctly setup those parameters before executing this macro.</p> <p>After this macro is executed, if the above parameters have been changed, it has to recreate the E-Cam table and this macro will have to be executed again. Data in E-Cam table will be changed after executing this macro; thus, do not execute it when E-Cam is in engaged status.</p> <p>In E-Cam application, parameters, such as P5-83 and P5-84 that are not related to this macro are not listed here. Users could setup parameters according to the real application. Please refer to Chapter 7, sections about E-Cam.</p> <p>After executing this macro, E-Cam table will not be saved to EEPROM automatically.</p>	
Failure code F061h	When creating the table, E-Cam is in engaged status.
Failure code F062h	The setting value of P5-94 exceeds the range: (1 ~ 65535)
Failure code F063h	The setting value of P5-95 exceeds the range: (1 ~ 65535)
Failure code F064h	The setting value of P5-96 exceeds the range: (300000 ~ 2500000)
Failure code F065h	The address specified by P5-81 is too long and the space of data array is not enough.
Failure code F066h	The setting value of P5-82 should be set to 7. Otherwise the command cannot be executed.
Failure code F067h	Data calculation error. Please decrease the setting value of (P1-44, P1-45) and keep the proportion will do.

Command code 0007h	Create E-Cam table: Flying cut
General parameters	<p>P5-81 = Address of table (data array)</p> <p>P5-82 = N (30~72) (Area number of E-Cam)</p> <p>P1-44, P1-45 = E-gear ration (has to be setup first)</p>
Macro parameters	<p>P5-93.H16 (high 16-bit) = S</p> <p>P5-93.L16 (low 16-bit) = W</p> <p>Among them:</p> <p>S (curve level) = 1~4 levels</p> <p>W (degree of waiting area) = -1~170 degrees</p> <p>W = -1 is available in firmware version V1.038 (sub29) (or the later version)</p> <p>P5-94 = Y (degree of synchronous area) = 0~330 degrees</p> <p>P5-95.H16 (high 16-bit) = A x C</p>



	<p>P5-95.L16 (low 16-bit) = B</p> <p>Among them:  A (Deceleration ratio: numerator), C (Number of cutter)  B (Deceleration ratio: denominator)</p> <p>P5-96 = 1000000 x R x V</p> <p>Among them:  R (cutting ratio) = L (target cutting length) / ℓ (Length of cutter)</p> <p>Allowable cutting ratio: (0.05 ~ 5.0) times</p> <p>V (speed factor) = target cutting speed / speed of delivered product</p> <p>V=1.0: When cutting, the speed of cutter is the same as the product</p> <p>V=1.1: When cutting, the speed of cutter is 10% faster than the product</p> <p>V=0.9: When cutting, the speed of cutter is 10% slower than the product</p>
<p>Note:</p> $W' = 180 + 360/N - 360/R + Y/2$ <p>When</p> <ol style="list-style-type: none"> <li>1. P5-93.L16 &lt; W', E-cam table is in error (failure code F07Ah)</li> <li>2. P5-93.L16 = W', the initial speed is 0 in E-Cam table</li> <li>3. P5-93.L16 &gt; W', the initial speed &gt; 0 in E-Cam table</li> </ol> <p>This macro will calculate the data of E-Cam table according to the above mentioned parameters, and store in data array which designated by P5-81. Parameters listed above are related to E-Cam table calculation. Please correctly setup those parameters before executing this macro.</p>	
<p>After this macro is executed, if the above parameters have been changed, it has to recreate the E-Cam table and this macro will have to be executed again. Data in E-Cam table will be changed after executing this macro; thus, do not execute it when E-Cam is in engaged status.</p> <p>In E-Cam application, parameters, such as P5-83 and P5-84 that are not related to this macro are not listed here. Users could setup parameters according to the real application. Please refer to Chapter 7, sections about</p> <p>After executing this macro, E-Cam table will not be saved to EEPROM automatically.</p>	
Failure code F071h	When creating the table, E-Cam is in engaged status.
Failure code F072h	P5-94 degree of synchronous area exceeds the range: (0 ~ 330)
Failure code F073h	P5-93.H16 curve level exceeds the range: (1 ~ 4)
Failure code F074h	P5-93.L16 degree of waiting area exceeds the range: (0 ~ 170)
Failure code F075h	The setting value of P5-96 exceeds the range: (50000 ~ 5000000)
Failure code F076h	P5-82 area number of E-Cam exceeds the range: (30 ~ 72)

Failure code F077h	The address specified by P5-81 is too long and the space of data array is not enough.
Failure code F078h	Data calculation error. Please decrease the setting value of (P1-44, P1-45) and keep the proportion will do.
Failure code F079h	Acceleration degree is too small, and then please decreases the value of waiting area (W), synchronous area (Y) or curve level (S).
Failure code F07Ah	Waiting area is too small, then please increase the value of acceleration area (W) or decrease the value of synchronous area (Y)

The following macros are available from version V1.042 sub09 (included):

Command code 0008h	E-Cam curve scaling (P5-19) is effective immediately
Macro parameters	N/A
<p>This macro can be triggered when E-cam is engaged. P5-19 is effective immediately.</p> <p>Usually, E-Cam scaling is only changed by P5-19 when it entering the engaged condition (see transition 3). It cannot be changed in engaged condition. E-Cam scaling only can be changed after one E-Cam cycle so as to make sure the E-Cam can return to the original position without accumulative error.</p>	
<p>In application, two ways can change the setting of E-Cam curve scaling.</p> <ol style="list-style-type: none"> <li><b>P5-88.X2 = 1:</b> When E-Cam is engaged, setup this bit at the same time. Function of P5-19 will be enabled immediately.</li> <li><b>Use macro#8:</b> Every time when this macro command is triggered, function of P5-19 will be enabled. However, if the value of P5-19 is changed and this macro is not triggered, function of P5-19 will not be enabled. This macro command has to be triggered again.</li> </ol>	
Failure code	N/A

The following macros are available from version V1.035 sub00 (included):

Command code 000Ch	Change position X, where E-Cam is engaged: E-Cam disengages after rotating one cycle at forward direction.
General parameters	N/A
Macro parameters	<p>P5-93 = New engaged position X. Unit: pulse number of master axis.</p> <p>Monitoring variable 062(3Eh): It displays the current engaged position (X) of master axis.</p>
This macro command can change the engaged position even when E-Cam is	

engaged. It will automatically calculate the residual engaged length. E-Cam will disengage after rotating one cycle at forward direction. Users have to set P5-88.U to 2, 4, and 6; otherwise, the E-cam will not disengage.

E-Cam will disengage when alarm occurs or the power supply is cut off. If users desire E-Cam to re-engage at the last disengaged position and continue its operation, it is recommended to record the disengaged position (X) and resume the operation by this macro command. Please note that when E-Cam is disengaged, the servo position might slightly shift and therefore cause position error when E-Cam re-engages again.

The Engaged direction is in forward direction (Master axis operates at forward direction):

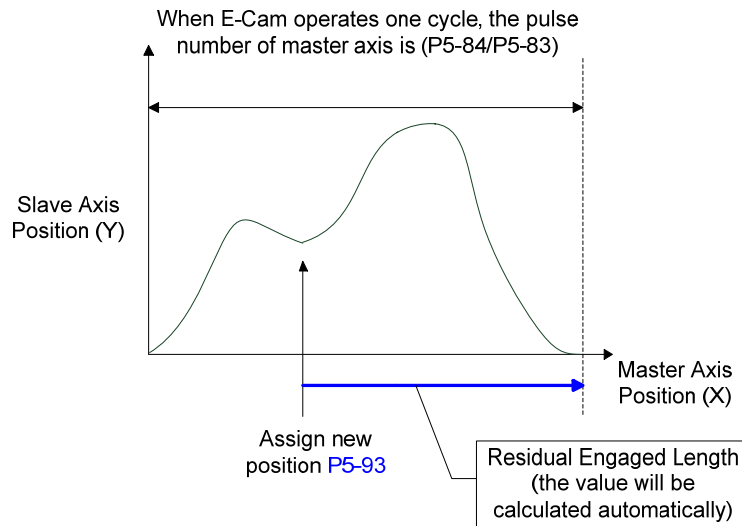



Note: When using this macro command, it would be better to execute this command before operate the master axis.

Failure code F0C1h	When executing this macro command, E-Cam is not in engaged status. To modify the engaged position only when E-Cam is engaged.
Failure code F0C2h	The setting value of P5-93 is in error. The value cannot less than 0. It should > = 0.
Failure code F0C3h	The setting value of P5-93 is in error. The value has to less than the value of (P5-84 / P5-83)

The following macros are available from version V1.038 sub48 (included):

Command code 000Dh	Calculate the error between E-Cam and indexing coordinates for PR positioning.
General Parameters	N/A
Macro Parameters	P5-93.Low_Word = DCBA: UZYX (8 digits, HEXADECIMAL) YX (PR number) = 0~0x3F (it is invalid when the value is set to 0) UZ: The value has to be set to 0. BA (Function of P5-95): 0 (Use avoid point) · 1 (Use available forward rate, V1.038 sub53)

	<p>DC (Inhibit reverse rotation):</p> <p>0 (invalid),</p> <p>1(Inhibit reverse rotation, V1.038 sub53)</p> <p>P5-95: Avoid point (cannot pass this point) = 0 ~ 100 (%) of E-Cam cycle or available forward rate 0 ~ 100 (%)</p>
<p>Monitoring variable 091(5Bh): It displays the current indexing coordinate position (PUU)</p>	
<p>When E-Cam is engaged, and the motor is stopped because of Servo Off or alarm occurs, it would cause position error between the actual position and E-Cam position. After re-servo On, this macro command can be used to calculate the correction value and write the value into the specified PR for incremental positioning. So that the motor can return to the ideal E-Cam position.</p> <p>When using this macro command:</p> <ol style="list-style-type: none"> <li>1. P5-88.X1 = 1 to make E-Cam keep engaging when servo off and continue to calculate E-Cam position.</li> <li>2. The height of indexing coordinate and E-Cam coordinate should be the same: P2-52= ECAM_H (The moving distance when E-cam operates one cycle)</li> <li>3. E-Cam table scaling (P5-19) must be 1.0 time</li> <li>4. When E-Cam is engaged for the first time, 0 degree of E-cam should aim at 0 degree of indexing coordinate.</li> <li>5. This macro command only can be applicable on periodic cycle and when every cycle starts from the same position.</li> </ol> <div data-bbox="427 974 1284 1254" style="text-align: center;"> </div> <p>Note 1: ECAM_H (height of E-Cam table) = E-Cam table (last point - first points)</p> <p>Note 2: Indexing coordinate = (absolute coordinates / P2-52) take remainder.</p> <p>Note 3: Use PR command for incremental positioning control.</p> <p>When motor moves from the current position to the target position, it can operate at forward or reverse direction. Due to the cyclic operation, the motor will travel to the specified position either at forward or reverse direction. However, the moving distance is different between both. Uses avoid point to plan the timing of forward and reverse rotation.</p> <p>* <b>Avoid point:</b> the point that cannot be passed by the planned PR.</p>	

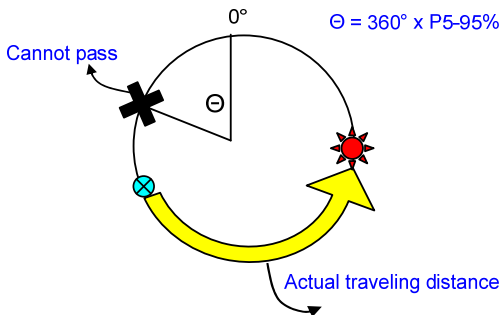
<p>  E-Cam current position   E-Cam current position   E-Cam avoid point <math>\Theta</math>, which is set by P5-95                 </p> 	
Failure code F0D1h	E-Cam is not engaged when executing this macro command. E-Cam should be engaged.
Failure code F0D2h	The value of P5-93.YX (PR number) exceeds the range: 1 ~ 0x3F
Failure code F0D3h	The value of P5-95 (available forward rate) exceeds the range: 0 ~ 100 (%)
Failure code F0D5h	The position correction value does not exist. This macro command might be triggered twice.
Failure code F0D6h	When re-servo On, E-cam is not engaged.
Failure code F0D7h	The height (Y axis) of E-Cam table is not equal to the value of P2-52.
Failure code F0D8h	P5-19 is not equal to 1
Failure code F0D9h	P5-93.BA, P5-95 exceeds the range: 0 ~ 1
Failure code F0DAh	The setting value of P5-93.DC (reverse inhibit) exceeds the range: 0 ~ 1
Failure code F0DBh	The function of reverse inhibit has failed. Do not use macro command #D, #10h consecutively.

The following macros are provided after version V1.038 sub26 (included):

Command code 000Eh	Perform E-Cam alignment immediately and write the correction value into the specified PR.
Macro parameters	<p>P5-93 = DCBA : UZYX (8 digits, HEXADECIMAL)</p> <p>YX (PR number) = 0~0x3F, it is invalid when the value is set to 0.</p> <p>UZ (Max. alignment correction rate) = 0~0x64 (%)</p> <p>A (Trigger the specified PR directly) = 1: On, 0: Off</p> <p>DCB = has to be set to 0</p> <p>P5-94 (DI delay time compensation) = -25000 ~ +25000; Unit: usec.</p> <p>P5-95 (available forward rate) = 0 ~ 100 (%)</p>

	P5-96 (target position of alignment X); Unit: pulse number of master axis = 0 ~ (P5-84/P5-83) – 1.
Monitoring variable 062(3Eh): It displays the current engaged position of master axis (X)	
<p>This macro command can move the engaged position to the alignment target position (X) when E-Cam is engaged. And write the alignment correction value into the specified PR.</p> <p>During E-Cam operation (When E-Cam is engaged), if desire to quickly align the E-cam position to the mechanical referral point, sensor can be used to trigger DI.EVx to execute this macro command.</p> <p>After E-Cam alignment is completed, the engaged position will move to the new position. The excess or not enough moving distance after E-Cam operates one cycle is called alignment correction value. It will be written into PR specified by P5-93.YX. PR incremental command can be used to compensate this value so that the slave axis position will remain and offset the phase of E-Cam to align the referral position of machine. For some applications, set value of P5-93.YX to 0 will do. Please note that PR can be executed only when triggering the host controller.</p> <div data-bbox="510 795 1300 1108" style="text-align: center;"> </div> <p>* P5-93.UZ is able to limit the max. correction rate. The alignment target position ★ will be different from P5-96.</p> <p>★   alignment target position★ – current engaged position   / L &lt;= P5-93.UZ %</p> <p>* DI time delay compensation can be set via P5-94, it can correct the error caused by different speed of motion.</p> <p>When E-Cam moves from current position to the target one, it can rotate at forward or reverse position. Due to the cyclic operation, it can reach the target position either at forward or reverse direction. However, the moving distance between both is usually different. Use available forward rate to plan the timing of forward and reverse rotation.</p> <p>* Available forward rate: The available max. proportion of forward path</p>	

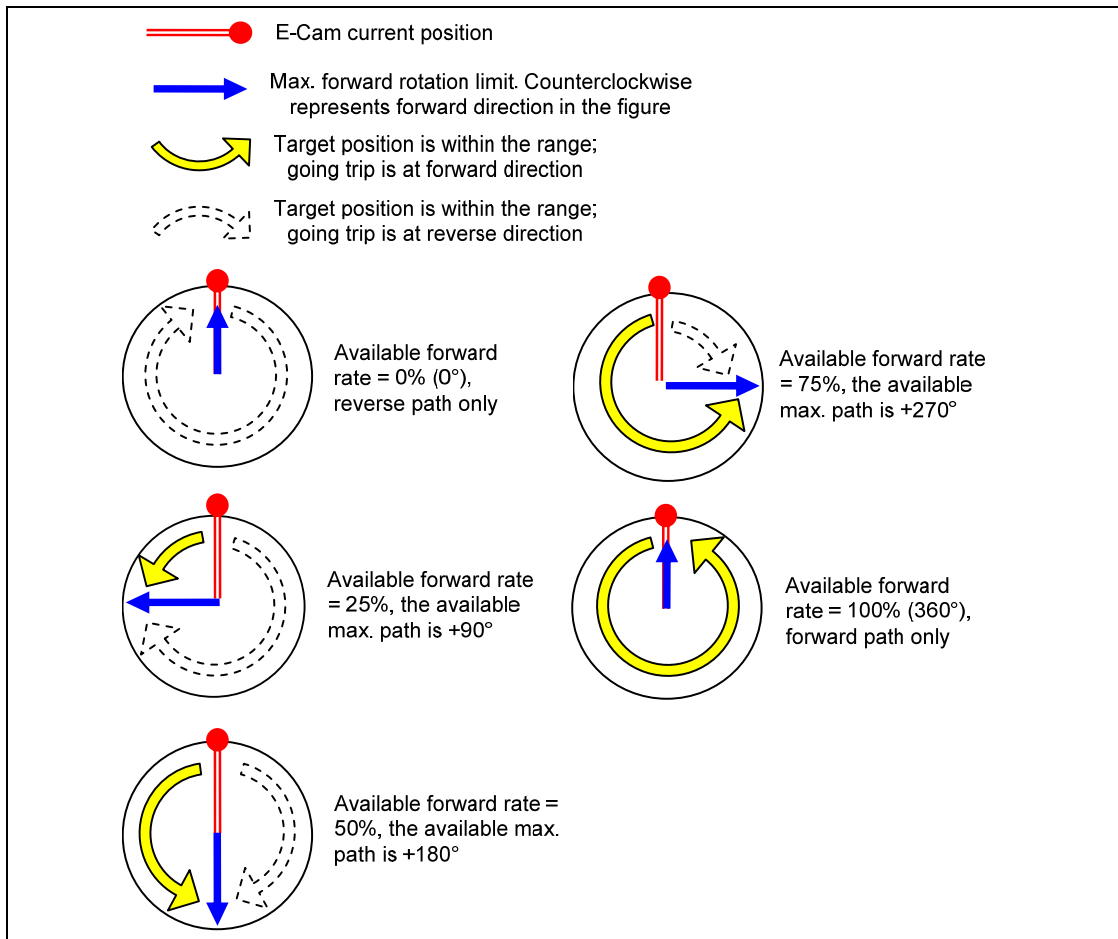

Failure code F0E1h	When executing this macro, E-Cam is not engaged. E-Cam has to engage to execute alignment correction.
Failure code F0E2h	The setting value of P5-93.YX (PR number) exceeds the range: 0 ~ 0x3F
Failure code F0E3h	The setting value of P5-93.UZ (Max. alignment correction rate) exceeds the range: 0~0x64 (%)
Failure code F0E4h	The setting value of P5-94 (DI delay time compensation) exceeds the range: -10000 ~ +10000
Failure code F0E5h	The setting value of P5-95 (Available forward rate) exceeds the range: 0 ~ 100 (%)
Failure code F0E6h	The setting value of P5-96 (alignment target position) exceeds the range: 0 ~ (P5-84/P5-83) - 1

The following macros are available from version V1.038 sub26 (included):

Command code 000Fh	Calculate the moving distance between current and target position of E-Cam for PR positioning.
General parameters	N/A
Macro parameters	P5-93.Low_Word = UZYX (4 digits, HEXADECIMAL) YX (PR number of going trip) = 0~0x3F, it is invalid if the value is set to 0. UZ (PR number of return trip) = 0~0x3F, it is invalid if the value is set to 0.

P5-93.Hi\_Word = it has to be set to 0  
 P5-95 (Available forward rate) = 0 ~ 100 (%)  
 P5-96 (target position X); Unit: pulse number of master axis =  
 0 ~ (P5-84/P5-83) - 1

Monitoring variable 062(3Eh): It displays the current engaged position (X) of master axis (X)

This macro command calculates the moving distance between current and target engaged position (X) and writes into the specified PR.

During E-Cam operation, if users desire to move the slave axis to the specified position when master axis stops and still in engaged status, this macro command can calculates the correct moving distance (Y\_Drift) of going trip for PR positioning.

When master axis resumes the operation, use another PR to run the moving distance of return trip (-Y\_Drift), it can back to the original position (moving distance of going trip + moving distance of return trip = 0). E-Cam position remains the same.

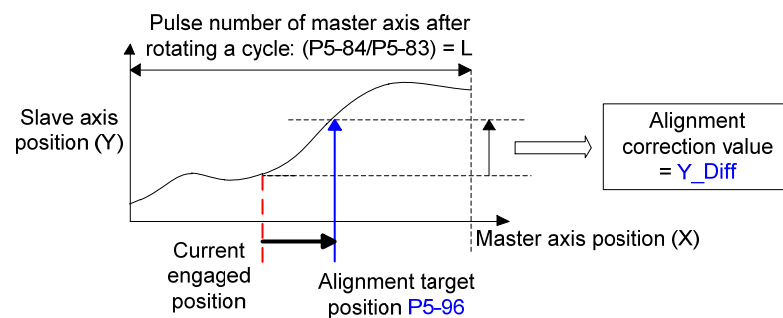

Note: PR command must be the incremental command, regardless in going trip or return trip.

When E-Cam moves from current position to the target one, it can rotate at forward or reverse position. Due to the cyclic operation, it can reach the target position either at forward or reverse direction. However, the moving distance between both is usually different. Use available forward rate to plan the timing of forward and reverse rotation.

\* Available forward rate: The available max. proportion of forward path



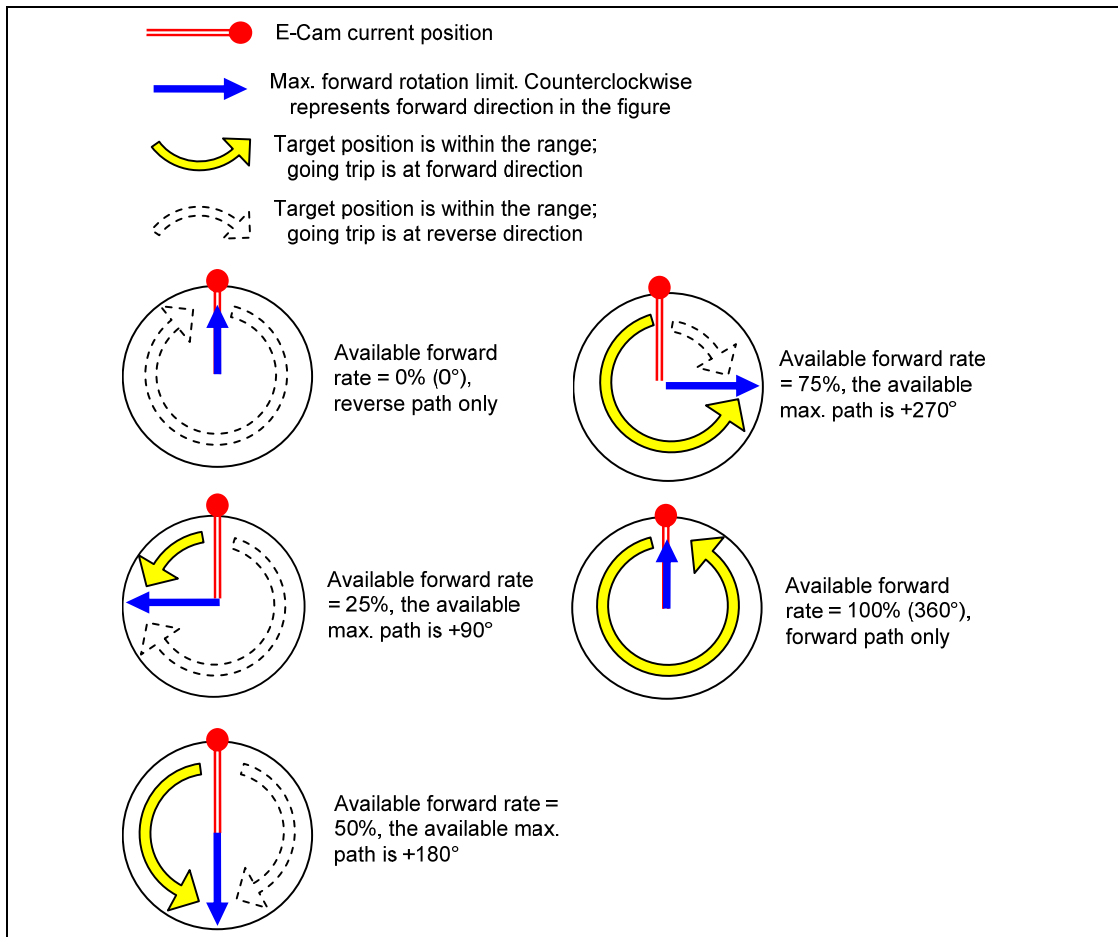

Failure code F0F1h	When executing this macro, E-Cam is not engaged. E-Cam has to engage to change the engaged position.
Failure code F0F2h	The setting value of P5-93.YX (PR number of going trip) exceeds the range: 0 ~ 0x3F
Failure code F0F3h	The setting value of P5-93.UZ (PR number of return trip) exceeds the range: 0 ~ 0x3F
Failure code F0F5h	The setting value of P5-95 (Available forward rate) exceeds the range: 0 ~ 100 (%)
Failure code F0F6h	The setting value of P5-96 (target position) exceeds the range: 0 ~ (P5-84/P5-83) - 1

The following macros are available from version V1.042 sub09 (included):

Command code 0010h	E-Cam stops for one cycle and resumes its operation at next cycle.
General parameters	N/A
Macro parameters	Value of P5-93 has to be set to 0.
<p>After E-Cam is engaged, this macro command can stop the slave axis for a cycle of distance regardless the E-Cam degree.</p> <p>The following conditions have to be established when using this macro command.</p> <ol style="list-style-type: none"> <li>1. E-Cam must be in engaged status.</li> <li>2. E-Cam must be the forward operation curve (including straight line) so it can stop temporally.</li> </ol>	

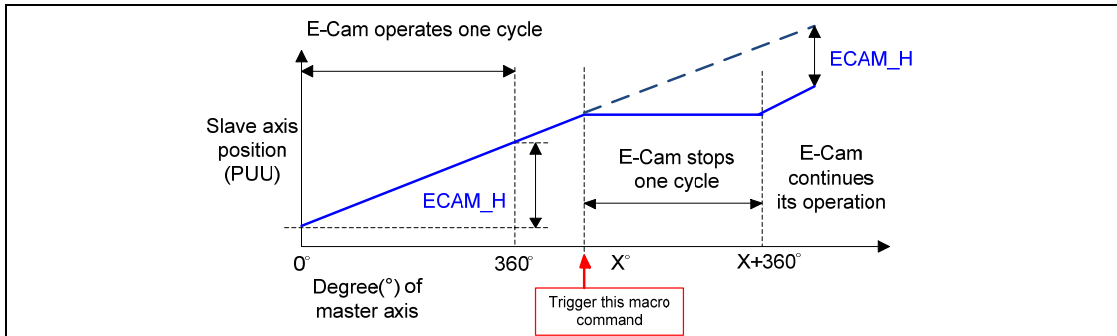

Refer to the figure below, triggering this macro command, E-Cam will stop for one cycle regardless the degree (X) where E-Cam is.

Note 1:  $ECAM\_H$  (E-Cam pause distance) = table (last point – first point) x P5-19 (the effective scaling)

Note 2: This function can accumulate times. If the command is triggered for N times consecutively, it will stop the E-Cam for N cycles. The accumulated pause distance cannot exceed ( $>2^{31}$ ), or the macro command will be disabled.

Note 3: When E-Cam resumes the operation, the accumulated pause distance will be cleared to 0.

Failure code F101h	When executing this macro command, E-Cam is not engaged.
Failure code F102h	The setting value of P5-93 is incorrect: It has to be set to 0.
Failure code F103h	E-Cam has to operate at forward direction. Please check the E-Cam table and make sure P5-19 > 0.
Failure code F104h	The <b>accumulated pause distance</b> exceeds $2^{31}$ . Do not execute this macro command consecutively.

Note: A2L does not support E-Cam function.

<b>P5-98</b>	<b>EVON</b>	<b>PR# Triggered by Event Rising-Edge</b>	<b>Address: 05C4H 05C5H</b>
	Operational Interface :	Panel / Software      Communication	Related Section: -
	Default :	0	
	Control Mode :	PR	
	Unit :	-	
	Range :	0000 ~ 0xDDDD	
	Data Size :	16-bit	
	Format :	Hexadecimal	

Settings : Four items: UZYX  
 When EVx is set to ON, the PR# will be executed.  
 X=0: When EV1 is ON, PR will not be triggered.  
 X=1~D: When EV1 is ON, execute PR # 51~63.  
 Y=0: When EV2 is ON, PR will not be triggered.  
 Y=1~D: When EV2 is ON, execute PR # 51~63.  
 Note: EV3 and EV4 are supported after firmware V1.009.  
  
 Z=0: When EV3 is ON, PR will not be triggered.  
 Z=1~D: When EV3 is ON, execute PR # 51~63.  
 U=0: When EV3 is ON, PR will not be triggered.  
 U=1~D: When EV4 is ON, execute PR # 51~63.

<b>P5-99</b>	<b>EVOF</b>	<b>PR# Triggered by Event Falling-Edge</b>	<b>Address: 05C6H 05C7H</b>
	Operational Interface :	Panel / Software	Communication
	Default :	0	
	Control Mode :	PR	
	Unit :	-	
	Range :	0000 ~ 0xDDDD	
	Data Size :	16-bit	
	Format :	Hexadecimal	

Related Section: -

Settings : Four items: UZYX  
 When EVx is set to OFF, the PR# will be executed.  
 X=0: When EV1 is OFF, PR will not be triggered.  
 X=1~D: When EV1 is OFF, execute PR # 51~63.  
 Y=0: When EV2 is OFF, PR will not be triggered.  
 Y=1~D: When EV2 is OFF, execute PR # 51~63.  
 Note: EV3 and EV4 are supported after firmware V1.009.  
 Z=0: When EV3 is OFF, PR will not be triggered.  
 Z=1~D: When EV3 is OFF, execute PR # 51~63.  
 U=0: When EV4 is OFF, PR will not be triggered.  
 U=1~D: When EV4 is OFF, execute PR # 51~63.

### P6-xx PR Parameters (Please refer to Chapter 7 for detailed setting)

P6-00	ODEF	Homing Definition		Address: 0600H 0601H				
Operational Interface :	Panel / Software	Communication		Related Section; 7.10				
Default :	0x00000000							
Control Mode :	PR							
Unit :	-							
Range :	0x00000000 ~ 0x10FFFF3F							
Data Size :	32-bit							
Format :	Hexadecimal							
Settings :	Homing definition:							
	.31 ~ 28	.27 ~ 24	.23 ~20	.19 ~ 16	.15 ~ 12	11 ~ 8	7 ~ 4	3 ~ 0
	BOOT	-	DLY	-	DEC1	ACC	PATH	

PATH: Path type (64-bit)

0: Stop: Homing complete and stop

1 ~ 3F: Auto: Homing complete and execute the specified path (Path#1 ~ Path#63)

ACC: Select 0~F for acceleration time and corresponds to P5-20~P5-35.

DEC1: The deceleration time selection of 1<sup>st</sup> homing, the setting value of DEC is 0~F and corresponds to P5-20 ~ P5-35.

DLY: Select 0~F for the delay time and corresponds to P5-40 ~ P5-55

BOOT: When the servo drive applies to the power, if it will be executed searching the origin.

0: Do not do homing

1: Execute homing automatically (SRV ON for the first time after applying to power)

Apart from the above mentioned definition, the related setting of homing also includes:

1. P5-04 Homing mode
2. P5-05 ~ P5-06 Speed setting of searching the origin
3. P6-01: ORG\_DEF is the location of the origin. It may not be 0. This function is the offset of coordinate system.

A. After the origin is found (Sensor or Z); it has to decelerate to stop. The stop position will exceed the origin for a short distance.

If it does not return to the origin, set PATH to 0.

If it needs to return to the origin, set PATH to non-zero value and set PABS = ORG\_DEF.

- B. If the origin is found (Sensor or Z), desire to move an offset S and define the coordinate as P after moving, then PATH = non-zero and set ORG\_DEF = P-S. The absolute position command = P.

<b>P6-01</b>	<b>ODAT</b>	<b>Origin Definition</b>						<b>Address: 0602H 0603H</b>			
	Operational Interface :	Panel / Software			Communication			Related Section: 7.10			
	Default :	0									
	Control Mode :	PR									
	Unit :	-									
	Range :	-2147483648 ~ +2147483647									
	Data Size :	32-bit									
	Format :	Decimal									
	Settings :	Value of origin definition:									
		.31 ~ 28	.27 ~ 24	.23 ~20	.19 ~ 16	.15 ~ 12	11 ~ 8			7 ~ 4	3 ~ 0
	ORG_DEF (32-bit)										

<b>P6-02</b>	<b>PDEF1</b>	<b>PATH#1 Definition</b>						<b>Address: 0604H 0605H</b>		
	Operational Interface :	Panel / Software			Communication			Related Section: 7.10		
	Default :	0x00000000								
	Control Mode :	PR								
	Unit :	-								
	Range :	0x00000000 ~ 0xFFFFFFFF								
	Data Size :	32-bit								
	Format :	Hexadecimal								

Settings : Properties of PATH# 1:

	.31 ~ 28	.27 ~ 24	.23 ~ 20	.19 ~ 16	.15 ~ 12	11 ~ 8	7 ~ 4	3 ~ 0
P6-02	-	-	DLY	-	-	-	OPT	TYPE
P6-03	DATA (32 bit)							

TYPE, OPT:

OPT				TYPE
7	6	5	4 BIT	3 ~ 0 BIT
-	UNIT	22AUTO	INS	1: SPEED, Speed setting control
CMD		OVLP	2INS	2: SINGLE, Positioning control. It will load in the next path when finished. 3: AUTO positioning control. It will load in the next path when finished.
-	-	-	INS	7: JUMP to the specified path
-	-	AUTO	INS	8: Write the specified parameter to the specified path

TYPE: 1 ~ 3 accept DO.STP stop and software limit.

INS: When executing this PR, it interrupts the previous one.

OVLP: Allow the overlap of the next path. The overlap is not allowed in speed mode. When overlap happens in position mode, DLY has no function.

AUTO: When PR procedure completes, the next procedure will be loaded in automatically.

CMD: Refer to Chapter 7 for PR command description.

DLY: 0 ~ F, delay time number (4 BIT). The delay after executing this PR. The external INS is invalid.

**24DLY (4)** Index P5-40 ~ P5-55

<b>P6-03</b>	<b>PDAT1</b>	<b>PATH# 1 Data</b>	<b>Address: 0606H 0607H</b>
	Operational Interface :	Panel / Software      Communication	Related Section: 7.10
	Default :	0	
	Control Mode :	PR	
	Unit :	-	
	Range :	-2147483648 ~ +2147483647	
	Data Size :	32-bit	
	Format :	Decimal	

Settings : PATH# 1 Data

.31 ~ 28	.27 ~ 24	.23 ~20	.19 ~ 16	.15 ~ 12	11 ~ 8	7 ~ 4	3 ~ 0
DATA (32 bit)							

Property of P6-02; P6-03 corresponds to the target position of P6-02 or jump to PATH\_NO.

 **NOTE** PATH (procedure)

<b>P6-04</b>	<b>PDEF2</b>	<b>PATH# 2 Definition</b>		<b>Address: 0608H 0609H</b>
	Operational Interface :	Panel / Software	Communication	Related Section: 7.10
	Default :	0x00000000		
	Control Mode :	PR		
	Unit :	-		
	Range :	0x00000000 ~ 0xFFFFFFFF		
	Data Size :	32-bit		
	Format :	Hexadecimal		
	Settings :	Please refer to the description of P6-02		

<b>P6-05</b>	<b>PDAT2</b>	<b>PATH# 2 Data</b>		<b>Address: 060AH 060BH</b>
	Operational Interface :	Panel / Software	Communication	Related Section: 7.10
	Default :	0		
	Control Mode :	PR		
	Unit :	-		
	Range :	-2147483648 ~ +2147483647		
	Data Size :	32-bit		
	Format :	Decimal		
	Settings :	Please refer to the description of P6-03.		

P6-06	PDEF3	PATH# 3 Definition	Address: 060CH 060DH
	Operational Interface :	Panel / Software	Communication
	Default :	0x00000000	
	Control Mode :	PR	
	Unit :	-	
	Range :	0x00000000 ~ 0xFFFFFFFF	
	Data Size :	32-bit	
	Format :	Hexadecimal	
	Settings :	Please refer to the description of P6-02.	

P6-07	PDAT3	PATH# 3 Data	Address: 060EH 060FH
	Operational Interface :	Panel / Software	Communication
	Default :	0	
	Control Mode :	PR	
	Unit :	-	
	Range :	-2147483648 ~ +2147483647	
	Data Size :	32-bit	
	Format :	Decimal	
	Settings :	Please refer to the description of P6-03.	

P6-08	PDEF4	PATH# 4 Definition	Address: 0610H 0611H
	Operational Interface :	Panel / Software	Communication
	Default :	0x00000000	
	Control Mode :	PR	
	Unit :	-	



Range :	0x00000000 ~ 0xFFFFFFFF
Data Size :	32-bit
Format :	Hexadecimal
Settings :	Please refer to the description of P6-02.

<b>P6-09</b>	<b>PDAT4</b>	<b>PATH# 4 Data</b>	<b>Address: 0612H 0613H</b>
	Operational Interface :	Panel / Software	Communication
	Default :	0	
	Control Mode :	PR	
	Unit :	-	
	Range :	-2147483648 ~ +2147483647	
	Data Size :	32-bit	
	Format :	Decimal	
	Settings :	Please refer to the description of P6-03.	
			Related Section: 7.10

<b>P6-10</b>	<b>PDEF5</b>	<b>PATH# 5 Definition</b>	<b>Address: 0614H 0615H</b>
	Operational Interface :	Panel / Software	Communication
	Default :	0x00000000	
	Control Mode :	PR	
	Unit :	-	
	Range :	0x00000000 ~ 0xFFFFFFFF	
	Data Size :	32-bit	
	Format :	Hexadecimal	
	Settings :	Please refer to the description of P6-02.	
			Related Section: 7.10

P6-11	PDAT5	PATH# 5 Data	Address: 0616H 0617H
	Operational Interface :	Panel / Software	Communication
	Default :	0	
	Control Mode :	PR	
	Unit :	-	
	Range :	-2147483648 ~ +2147483647	
	Data Size :	32-bit	
	Format :	Decimal	
	Settings :	Please refer to the description of P6-03.	
			Related Section: 7.10

P6-12	PDEF6	PATH# 6 Definition	Address: 0618H 0619H
	Operational Interface :	Panel / Software	Communication
	Default :	0x00000000	
	Control Mode :	PR	
	Unit :	-	
	Range :	0x00000000 ~ 0xFFFFFFFF	
	Data Size :	32-bit	
	Format :	Hexadecimal	
	Settings :	Please refer to the description of P6-02.	
			Related Section: 7.10

P6-13	PDAT6	PATH# 6 Data	Address: 061AH 061BH
	Operational Interface :	Panel / Software	Communication
	Default :	0	
	Control Mode :	PR	
	Unit :	-	
			Related Section: 7.10

Range :	-2147483648 ~ +2147483647
Data Size :	32-bit
Format :	Decimal
Settings :	Please refer to the description of P6-03.

<b>P6-14</b>	<b>PDEF7</b>	<b>PATH# 7 Definition</b>	<b>Address: 061CH 061DH</b>
	Operational Interface :	Panel / Software	Communication
	Default :	0x00000000	
	Control Mode :	PR	
	Unit :	-	
	Range :	0x00000000 ~ 0xFFFFFFFF	
	Data Size :	32-bit	
	Format :	Hexadecimal	
	Settings :	Please refer to the description of P6-02.	

<b>P6-15</b>	<b>PDAT7</b>	<b>PATH# 7 Data</b>	<b>Address: 061EH 061FH</b>
	Operational Interface :	Panel / Software	Communication
	Default :	0	
	Control Mode :	PR	
	Unit :	-	
	Range :	-2147483648 ~ +2147483647	
	Data Size :	32-bit	
	Format :	Decimal	
	Settings :	Please refer to the description of P6-03.	

P6-16	PDEF8	PATH# 8 Definition	Address: 0620H 0621H
	Operational Interface :	Panel / Software      Communication	Related Section: 7.10
	Default :	0x00000000	
	Control Mode :	PR	
	Unit :	-	
	Range :	0x00000000 ~ 0xFFFFFFFF	
	Data Size :	32-bit	
	Format :	Hexadecimal	
	Settings :	Please refer to the description of P6-02.	

P6-17	PDAT8	PATH# 8 Data	Address: 0622H 0623H
	Operational Interface :	Panel / Software      Communication	Related Section: 7.10
	Default :	0	
	Control Mode :	PR	
	Unit :	-	
	Range :	-2147483648 ~ +2147483647	
	Data Size :	32-bit	
	Format :	Decimal	
	Settings :	Please refer to the description of P6-03.	

P6-18	PDEF9	PATH# 9 Definition	Address: 0624H 0625H
	Operational Interface :	Panel / Software      Communication	Related Section: 7.10
	Default :	0x00000000	
	Control Mode :	PR	
	Unit :	-	

Range :	0x00000000 ~ 0xFFFFFFFF
Data Size :	32-bit
Format :	Hexadecimal
Settings :	Please refer to the description of P6-02.

<b>P6-19</b>	<b>PDAT9</b>	<b>PATH# 9 Data</b>	<b>Address: 0626H 0627H</b>
	Operational Interface :	Panel / Software	Communication
	Default :	0	
	Control Mode :	PR	
	Unit :	-	
	Range :	-2147483648 ~ +2147483647	
	Data Size :	32-bit	
	Format :	Decimal	
	Settings :	Please refer to the description of P6-03.	

<b>P6-20</b>	<b>PDEF10</b>	<b>PATH# 10 Definition</b>	<b>Address: 0628H 0629H</b>
	Operational Interface :	Panel / Software	Communication
	Default :	0x00000000	
	Control Mode :	PR	
	Unit :	-	
	Range :	0x00000000 ~ 0xFFFFFFFF	
	Data Size :	32-bit	
	Format :	Hexadecimal	
	Settings :	Please refer to the description of P6-02.	

<b>P6-21</b>	<b>PDAT10</b>	<b>PATH# 10 Data</b>	<b>Address: 062AH 062BH</b>
	Operational Interface :	Panel / Software	Communication
	Default :	0	
	Control Mode :	PR	
	Range :	-2147483648 ~ +2147483647	
	Data Size :	32-bit	
	Format :	Decimal	
	Settings :	Please refer to the description of P6-03	
<b>P6-22</b>	<b>PDEF11</b>	<b>PATH# 11 Definition</b>	<b>Address: 062CH 062DH</b>
	Operational Interface :	Panel / Software	Communication
	Default :	0x00000000	
	Control Mode :	PR	
	Unit :	-	
	Range :	0x00000000 ~ 0xFFFFFFFF	
	Data Size :	32-bit	
	Format :	Hexadecimal	
Settings :	Please refer to the description of P6-02.		
<b>P6-23</b>	<b>PDAT11</b>	<b>PATH# 11 Data</b>	<b>Address: 062EH 062FH</b>
	Operational Interface :	Panel / Software	Communication
	Default :	0	
	Control Mode :	PR	
	Unit :	-	
	Range :	-2147483648 ~ +2147483647	
	Data Size :	32-bit	

Format : Decimal  
 Settings : Please refer to the description of P6-03.

<b>P6-24</b>	<b>PDEF12</b>	<b>PATH# 12 Definition</b>		<b>Address: 0630H 0631H</b>
	Operational Interface :	Panel / Software	Communication	Related Section: 7.10
	Default :	0x00000000		
	Control Mode :	PR		
	Unit :	-		
	Range :	0x00000000 ~ 0xFFFFFFFF		
	Data Size :	32-bit		
	Format :	Hexadecimal		
Settings :	Please refer to the description of P6-02.			

<b>P6-25</b>	<b>PDAT12</b>	<b>PATH# 12 Data</b>		<b>Address: 0632H 0633H</b>
	Operational Interface :	Panel / Software	Communication	Related Section: 7.10
	Default :	0		
	Control Mode :	PR		
	Unit :	-		
	Range :	-2147483648 ~ +2147483647		
	Data Size :	32-bit		
	Format :	Decimal		
Settings :	Please refer to the description of P6-03.			

P6-26	PDEF13	PATH# 13 Definition	Address: 0634H 0635H
Operational Interface :		Panel / Software	Communication
Default :		0x00000000	
Control Mode :		PR	
Unit :		-	
Range :		0x00000000 ~ 0xFFFFFFFF	
Data Size :		32-bit	
Format :		Hexadecimal	
Settings : Please refer to the description of P6-02.			

P6-27	PDAT13	PATH# 13 Data	Address: 0636H 0637H
Operational Interface :		Panel / Software	Communication
Default :		0	
Control Mode :		PR	
Unit :		-	
Range :		-2147483648 ~ +2147483647	
Data Size :		32-bit	
Format :		Decimal	
Settings : Please refer to the description of P6-03.			

P6-28	PDEF14	PATH# 14 Definition	Address: 0638H 0639H
Operational Interface :		Panel / Software	Communication
Default :		0x00000000	
Control Mode :		PR	
Unit :		-	



Range :	0x00000000 ~ 0xFFFFFFFF
Data Size :	32-bit
Format :	Hexadecimal
Settings :	Please refer to the description of P6-03.

<b>P6-29</b>	<b>PDAT14</b>	<b>PATH# 14 Data</b>	<b>Address: 063AH 063BH</b>
	Operational Interface :	Panel / Software	Communication
	Default :	0	
	Control Mode :	PR	
	Unit :	-	
	Range :	-2147483648 ~ +2147483647	
	Data Size :	32-bit	
	Format :	Decimal	
	Settings :	Please refer to the description of P6-03.	

<b>P6-30</b>	<b>PDEF15</b>	<b>PATH# 15 Definition</b>	<b>Address: 063CH 063DH</b>
	Operational Interface :	Panel / Software	Communication
	Default :	0x00000000	
	Control Mode :	PR	
	Unit :	-	
	Range :	0x00000000 ~ 0xFFFFFFFF	
	Data Size :	32-bit	
	Format :	Hexadecimal	
	Settings :	Please refer to the description of P6-02.	

P6-31	PDAT15	PATH# 15 Data	Address: 063EH 063FH
Operational Interface :		Panel / Software	Communication
Default :		0	
Control Mode :		PR	
Unit :		-	
Range :		-2147483648 ~ +2147483647	
Data Size :		32-bit	
Format :		Decimal	
Settings : Please refer to the description of P6-03.			

P6-32	PDEF16	PATH# 16 Definition	Address: 0640H 0641H
Operational Interface :		Panel / Software	Communication
Default :		0x00000000	
Control Mode :		PR	
Unit :		-	
Range :		0x00000000 ~ 0xFFFFFFFF	
Data Size :		32-bit	
Format :		Hexadecimal	
Settings : Please refer to the description of P6-02.			

P6-33	PDAT16	PATH# 16 Data	Address: 0642H 0643H
Operational Interface :		Panel / Software	Communication
Default :		0	
Control Mode :		PR	
Unit :		-	

Range :	-2147483648 ~ +2147483647
Data Size :	32-bit
Format :	Decimal
Settings :	Please refer to the description of P6-03.

<b>P6-34</b>	<b>PDEF17</b>	<b>PATH# 17 Definition</b>	<b>Address: 0644H 0645H</b>
	Operational Interface :	Panel / Software	Communication
	Default :	0x00000000	
	Control Mode :	PR	
	Unit :	-	
	Range :	0x00000000 ~ 0xFFFFFFFF	
	Data Size :	32-bit	
	Format :	Hexadecimal	
	Settings :	Please refer to the description of P6-02.	
			Related Section: 7.10

<b>P6-35</b>	<b>PDAT17</b>	<b>PATH# 17 Data</b>	<b>Address: 0646H 0647H</b>
	Operational Interface :	Panel / Software	Communication
	Default :	0	
	Control Mode :	PR	
	Unit :	-	
	Range :	-2147483648 ~ +2147483647	
	Data Size :	32-bit	
	Format :	Decimal	
	Settings :	Please refer to the description of P6-03.	
			Related Section: 7.10

P6-36	PDEF18	PATH# 18 Definition	Address: 0648H 0649H
	Operational Interface :	Panel / Software      Communication	Related Section: 7.10
	Default :	0x00000000	
	Control Mode :	PR	
	Unit :	-	
	Range :	0x00000000 ~ 0xFFFFFFFF	
	Data Size :	32-bit	
	Format :	Hexadecimal	
	Settings :	Please refer to the description of P6-02.	

P6-37	PDAT18	PATH# 18 Data	Address: 064AH 064BH
	Operational Interface :	Panel / Software      Communication	Related Section: 7.10
	Default :	0	
	Control Mode :	PR	
	Unit :	-	
	Range :	-2147483648 ~ +2147483647	
	Data Size :	32-bit	
	Format :	Decimal	
	Settings :	Please refer to the description of P6-03.	

P6-38	PDEF19	PATH# 19 Definition	Address: 064CH 064DH
	Operational Interface :	Panel / Software      Communication	Related Section: 7.10
	Default :	0x00000000	
	Control Mode :	PR	
	Unit :	-	

Range :	0x00000000 ~ 0xFFFFFFFF
Data Size :	32-bit
Format :	Hexadecimal
Settings :	Please refer to the description of P6-02.

P6-39	P DAT19	PATH# 19 Data	Address: 064EH 064FH
Operational Interface :	Panel / Software	Communication	Related Section: 7.10
Default :	0		
Control Mode :	PR		
Unit :	-		
Range :	-2147483648 ~ +2147483647		
Data Size :	32-bit		
Format :	Decimal		
Settings :	Please refer to the description of P6-03.		

P6-40	P DEF20	PATH# 20 Definition	Address: 0650H 0651H
Operational Interface :	Panel / Software	Communication	Related Section: 7.10
Default :	0x00000000		
Control Mode :	PR		
Unit :	-		
Range :	0x00000000 ~ 0xFFFFFFFF		
Data Size :	32-bit		
Format :	Hexadecimal		
Settings :	Please refer to the description of P6-02.		

P6-41	PDAT20	PATH# 20 Data	Address: 0652H 0653H
	Operational Interface :	Panel / Software      Communication	Related Section: 7.10
	Default :	0	
	Control Mode :	PR	
	Unit :	-	
	Range :	-2147483648 ~ +2147483647	
	Data Size :	32-bit	
	Format :	Decimal	
	Settings :	Please refer to the description of P6-03.	

P6-42	PDEF21	PATH# 21 Definition	Address: 0654H 0655H
	Operational Interface :	Panel / Software      Communication	Related Section: 7.10
	Default :	0x00000000	
	Control Mode :	PR	
	Unit :	-	
	Range :	0x00000000 ~ 0xFFFFFFFF	
	Data Size :	32-bit	
	Format :	Hexadecimal	
	Settings :	Please refer to the description of P6-02.	

P6-43	PDAT21	PATH# 21 Data	Address: 0656H 0657H
	Operational Interface :	Panel / Software      Communication	Related Section: 7.10
	Default :	0	
	Control Mode :	PR	
	Unit :	-	
	Range :	-2147483648 ~ +2147483647	

Data Size :	32-bit
Format :	Decimal
Settings :	Please refer to the description of P6-03.

P6-44	PDEF22	PATH# 22 Definition	Address: 0658H 0659H
Operational Interface :	Panel / Software	Communication	Related Section: 7.10
Default :	0x00000000		
Control Mode :	PR		
Unit :	-		
Range :	0x00000000 ~ 0xFFFFFFFF		
Data Size :	32-bit		
Format :	Hexadecimal		
Settings :	Please refer to the description of P6-02.		

P6-45	PDAT22	PATH# 22Data	Address: 065AH 065BH
Operational Interface :	Panel / Software	Communication	Related Section: 7.10
Default :	0		
Control Mode :	PR		
Unit :	-		
Range :	-2147483648 ~ +2147483647		
Data Size :	32-bit		
Format :	Decimal		
Settings :	Please refer to the description of P6-03.		

P6-46	PDEF23	PATH# 23Definition	Address: 065CH 065DH
	Operational Interface :	Panel / Software      Communication	Related Section: 7.10
	Default :	0x00000000	
	Control Mode :	PR	
	Unit :	-	
	Range :	0x00000000 ~ 0xFFFFFFFF	
	Data Size :	32-bit	
	Format :	Hexadecimal	
	Settings :	Please refer to the description of P6-02.	

P6-47	PDAT23	PATH# 23Data	Address: 065EH 065FH
	Operational Interface :	Panel / Software      Communication	Related Section: 7.10
	Default :	0	
	Control Mode :	PR	
	Unit :	-	
	Range :	-2147483648 ~ +2147483647	
	Data Size :	32-bit	
	Format :	Decimal	
	Settings :	Please refer to the description of P6-03.	

P6-48	PDEF24	PATH# 24Definition	Address: 0660H 0661H
	Operational Interface :	Panel / Software      Communication	Related Section: 7.10
	Default :	0x00000000	
	Control Mode :	PR	
	Unit :	-	



Range :	0x00000000 ~ 0xFFFFFFFF
Data Size :	32-bit
Format :	Hexadecimal
Settings :	Please refer to the description of P6-02.

<b>P6-49</b>	<b>PDAT24</b>	<b>PATH# 24Data</b>	<b>Address: 0662H 0663H</b>
	Operational Interface :	Panel / Software	Communication
	Default :	0	
	Control Mode :	PR	
	Unit :	-	
	Range :	-2147483648 ~ +2147483647	
	Data Size :	32-bit	
	Format :	Decimal	
	Settings :	Please refer to the description of P6-03.	

<b>P6-50</b>	<b>PDEF25</b>	<b>PATH# 25Definition</b>	<b>Address: 0664H 0665H</b>
	Operational Interface :	Panel / Software	Communication
	Default :	0x00000000	
	Control Mode :	PR	
	Unit :	-	
	Range :	0x00000000 ~ 0xFFFFFFFF	
	Data Size :	32-bit	
	Format :	Hexadecimal	
	Settings :	Please refer to the description of P6-02.	

<b>P6-51</b>	<b>PDAT25</b>	<b>PATH# 25Data</b>	<b>Address: 0666H 0667H</b>
	Operational Interface :	Panel / Software	Communication
	Default :	0	
	Control Mode :	PR	
	Unit :	-	
	Range :	-2147483648 ~ +2147483647	
	Data Size :	32-bit	
	Format :	Decimal	
Settings : Please refer to the description of P6-03			
<b>P6-52</b>	<b>PDEF26</b>	<b>PATH# 26Definition</b>	<b>Address: 0668H 0669H</b>
	Operational Interface :	Panel / Software	Communication
	Default :	0x00000000	
	Control Mode :	PR	
	Unit :	-	
	Range :	0x00000000 ~ 0xFFFFFFFF	
	Data Size :	32-bit	
	Format :	Hexadecimal	
Settings : Please refer to the description of P6-02.			
<b>P6-53</b>	<b>PDAT26</b>	<b>PATH# 26Data</b>	<b>Address: 066AH 066BH</b>
	Operational Interface :	Panel / Software	Communication
	Default :	0	
	Control Mode :	PR	
	Unit :	-	
	Range :	-2147483648 ~ +2147483647	

Data Size :	32-bit
Format :	Decimal
Settings :	Please refer to the description of P6-03.

<b>P6-54</b>	<b>PDEF27</b>	<b>PATH# 27Definition</b>	<b>Address: 066CH 066DH</b>
	Operational Interface :	Panel / Software	Communication
	Default :	0x00000000	
	Control Mode :	PR	
	Unit :	-	
	Range :	0x00000000 ~ 0xFFFFFFFF	
	Data Size :	32-bit	
	Format :	Hexadecimal	
Settings : Please refer to the description of P6-02.			

<b>P6-55</b>	<b>PDAT27</b>	<b>PATH# 27Data</b>	<b>Address: 066EH 066FH</b>
	Operational Interface :	Panel / Software	Communication
	Default :	0	
	Control Mode :	PR	
	Unit :	-	
	Range :	-2147483648 ~ +2147483647	
	Data Size :	32-bit	
	Format :	Decimal	
Settings : Please refer to the description of P6-03.			

P6-56	PDEF28	PATH# 28	Definition	Address: 0670H 0671H
Operational Interface :		Panel / Software	Communication	Related Section: 7.10
Default :		0x00000000		
Control Mode :		PR		
Unit :		-		
Range :		0x00000000 ~ 0xFFFFFFFF		
Data Size :		32-bit		
Format :		Hexadecimal		
Settings :		Please refer to the description of P6-02.		

P6-57	PDAT28	PATH# 28	Data	Address: 0672H 0673H
Operational Interface :		Panel / Software	Communication	Related Section: 7.10
Default :		0		
Control Mode :		PR		
Unit :		-		
Range :		-2147483648 ~ +2147483647		
Data Size :		32-bit		
Format :		Decimal		
Settings :		Please refer to the description of P6-03.		

P6-58	PDEF29	PATH# 29	Definition	Address: 0674H 0675H
Operational Interface :		Panel / Software	Communication	Related Section: 7.10
Default :		0x00000000		
Control Mode :		PR		
Unit :		-		

Range :	0x00000000 ~ 0xFFFFFFFF
Data Size :	32-bit
Format :	Hexadecimal
Settings :	Please refer to the description of P6-02.

P6-59	P DAT29	PATH# 29Data	Address: 0676H 0677H
Operational Interface :	Panel / Software	Communication	Related Section: 7.10
Default :	0		
Control Mode :	PR		
Unit :	-		
Range :	-2147483648 ~ +2147483647		
Data Size :	32-bit		
Format :	Decimal		
Settings :	Please refer to the description of P6-03.		

P6-60	P DEF30	PATH# 30Definition	Address: 0678H 0679H
Operational Interface :	Panel / Software	Communication	Related Section: 7.10
Default :	0x00000000		
Control Mode :	PR		
Unit :	-		
Range :	0x00000000 ~ 0xFFFFFFFF		
Data Size :	32-bit		
Format :	Hexadecimal		
Settings :	Please refer to the description of P6-02.		

P6-61	PDAT30	PATH# 30Data	Address: 067AH 067BH
Operational Interface :		Panel / Software	Communication
Default :		0	
Control Mode :		PR	
Unit :		-	
Range :		-2147483648 ~ +2147483647	
Data Size :		32-bit	
Format :		Decimal	
Settings : Please refer to the description of P6-03.			

P6-62	PDEF31	PATH# 31Definition	Address: 067CH 067DH
Operational Interface :		Panel / Software	Communication
Default :		0x00000000	
Control Mode :		PR	
Unit :		-	
Range :		0x00000000 ~ 0xFFFFFFFF	
Data Size :		32-bit	
Format :		Hexadecimal	
Settings : Please refer to the description of P6-02.			

P6-63	PDAT31	PATH# 31Data	Address: 067EH 067FH
Operational Interface :		Panel / Software	Communication
Default :		0	
Control Mode :		PR	
Unit :		-	

Range :	-2147483648 ~ +2147483647
Data Size :	32-bit
Format :	Decimal
Settings :	Please refer to the description of P6-03

P6-64	PDEF32	PATH# 32Definition	Address: 0680H 0681H
Operational Interface :	Panel / Software	Communication	Related Section: 7.10
Default :	0x00000000		
Control Mode :	PR		
Unit :	-		
Range :	0x00000000 ~ 0xFFFFFFFF		
Data Size :	32-bit		
Format :	Hexadecimal		
Settings :	Please refer to the description of P6-02.		

P6-65	PDAT32	PATH# 32Data	Address: 0682H 0683H
Operational Interface :	Panel / Software	Communication	Related Section: 7.10
Default :	0		
Control Mode :	PR		
Unit :	-		
Range :	-2147483648 ~ +2147483647		
Data Size :	32-bit		
Format :	Decimal		
Settings :	Please refer to the description of P6-03.		

P6-66	PDEF33	PATH# 33Definition	Address: 0684H 0685H
	Operational Interface :	Panel / Software      Communication	Related Section: 7.10
	Default :	0x00000000	
	Control Mode :	PR	
	Unit :	-	
	Range :	0x00000000 ~ 0xFFFFFFFF	
	Data Size :	32-bit	
	Format :	Hexadecimal	
	Settings :	Please refer to the description of P6-02.	
P6-67	PDAT33	PATH# 33Data	Address: 0686H 0687H
	Operational Interface :	Panel / Software      Communication	Related Section: 7.10
	Default :	0	
	Control Mode :	PR	
	Unit :	-	
	Range :	-2147483648 ~ +2147483647	
	Data Size :	32-bit	
	Format :	Decimal	
	Settings :	Please refer to the description of P6-03.	
P6-68	PDEF34	PATH# 34Definition	Address: 0688H 0689H
	Operational Interface :	Panel / Software      Communication	Related Section: 7.10
	Default :	0x00000000	
	Control Mode :	PR	
	Unit :	-	



Range :	0x00000000 ~ 0xFFFFFFFF
Data Size :	32-bit
Format :	Hexadecimal
Settings :	Please refer to the description of P6-02.

<b>P6-69</b>	<b>PDAT34</b>	<b>PATH# 34Data</b>	<b>Address: 068AH 068BH</b>
	Operational Interface :	Panel / Software	Communication
	Default :	0	
	Control Mode :	PR	
	Unit :	-	
	Range :	-2147483648 ~ +2147483647	
	Data Size :	32-bit	
	Format :	Decimal	
	Settings :	Please refer to the description of P6-03.	

<b>P6-70</b>	<b>PDEF35</b>	<b>PATH# 35Definition</b>	<b>Address: 068CH 068DH</b>
	Operational Interface :	Panel / Software	Communication
	Default :	0x00000000	
	Control Mode :	PR	
	Unit :	-	
	Range :	0x00000000 ~ 0xFFFFFFFF	
	Data Size :	32-bit	
	Format :	Hexadecimal	
	Settings :	Please refer to the description of P6-02.	

<b>P6-71</b>	<b>PDAT35</b>	<b>PATH# 35Data</b>	<b>Address: 068EH 068FH</b>
	Operational Interface :	Panel / Software      Communication	Related Section: 7.10
	Default :	0	
	Control Mode :	PR	
	Unit :	-	
	Range :	-2147483648 ~ +2147483647	
	Data Size :	32-bit	
	Format :	Decimal	
	Settings : Please refer to the description of P6-03.		
<b>P6-72</b>	<b>PDEF36</b>	<b>PATH# 36Definition</b>	<b>Address: 0690H 0691H</b>
	Operational Interface :	Panel / Software      Communication	Related Section: 7.10
	Default :	0x00000000	
	Control Mode :	PR	
	Unit :	-	
	Range :	0x00000000 ~ 0xFFFFFFFF	
	Data Size :	32-bit	
	Format :	Hexadecimal	
	Settings : Please refer to the description of P6-02.		
<b>P6-73</b>	<b>PDAT36</b>	<b>PATH# 36Data</b>	<b>Address: 0692H 0693H</b>
	Operational Interface :	Panel / Software      Communication	Related Section: 7.10
	Default :	0	
	Control Mode :	PR	
	Unit :	-	

Range :	-2147483648 ~ +2147483647
Data Size :	32-bit
Format :	Decimal
Settings :	Please refer to the description of P6-03.

<b>P6-74</b>	<b>PDEF37</b>	<b>PATH# 37</b>	<b>Definition</b>	<b>Address: 0694H 0695H</b>
	Operational Interface :	Panel / Software	Communication	Related Section: 7.10
	Default :	0x00000000		
	Control Mode :	PR		
	Unit :	-		
	Range :	0x00000000 ~ 0xFFFFFFFF		
	Data Size :	32-bit		
	Format :	Hexadecimal		
Settings : Please refer to the description of P6-02.				

<b>P6-75</b>	<b>PDAT37</b>	<b>PATH# 37</b>	<b>Data</b>	<b>Address: 0696H 0697H</b>
	Operational Interface :	Panel / Software	Communication	Related Section: 7.10
	Default :	0		
	Control Mode :	PR		
	Unit :	-		
	Range :	-2147483648 ~ +2147483647		
	Data Size :	32-bit		
	Format :	Decimal		
Settings : Please refer to the description of P6-03.				

P6-76	PDEF38	PATH# 38	Definition	Address: 0698H 0699H
	Operational Interface :	Panel / Software	Communication	Related Section: 7.10
	Default :	0x00000000		
	Control Mode :	PR		
	Unit :	-		
	Range :	0x00000000 ~ 0xFFFFFFFF		
	Data Size :	32-bit		
	Format :	Hexadecimal		
	Settings :	Please refer to the description of P6-02.		

P6-77	PDAT38	PATH# 38	Data	Address: 069AH 069BH
	Operational Interface :	Panel / Software	Communication	Related Section: 7.10
	Default :	0		
	Control Mode :	PR		
	Unit :	-		
	Range :	-2147483648 ~ +2147483647		
	Data Size :	32-bit		
	Format :	Decimal		
	Settings :	Please refer to the description of P6-03.		

P6-78	PDEF39	PATH# 39	Definition	Address: 069CH 069DH
	Operational Interface :	Panel / Software	Communication	Related Section: 7.10
	Default :	0x00000000		
	Control Mode :	PR		
	Unit :	-		

Range :	0x00000000 ~ 0xFFFFFFFF
Data Size :	32-bit
Format :	Hexadecimal
Settings :	Please refer to the description of P6-02.

<b>P6-79</b>	<b>PDAT39</b>	<b>PATH# 39Data</b>	<b>Address: 069EH 069FH</b>
	Operational Interface :	Panel / Software	Communication
	Default :	0	
	Control Mode :	PR	
	Unit :	-	
	Range :	-2147483648 ~ +2147483647	
	Data Size :	32-bit	
	Format :	Decimal	
	Settings :	Please refer to the description of P6-03.	
Related Section: 7.10			

<b>P6-80</b>	<b>PDEF40</b>	<b>PATH# 40Definition</b>	<b>Address: 06A0H 06A1H</b>
	Operational Interface :	Panel / Software	Communication
	Default :	0x00000000	
	Control Mode :	PR	
	Unit :	-	
	Range :	0x00000000 ~ 0xFFFFFFFF	
	Data Size :	32-bit	
	Format :	Hexadecimal	
	Settings :	Please refer to the description of P6-02.	
Related Section: 7.10			

P6-81	PDATA40	PATH# 40Data	Address: 06A2H 06A3H
Operational Interface :		Panel / Software	Communication
Default :		0	
Control Mode :		PR	
Unit :		-	
Range :		-2147483648 ~ +2147483647	
Data Size :		32-bit	
Format :		Decimal	
Settings : Please refer to the description of P6-03.			

P6-82	PDEF41	PATH# 41Definition	Address: 06A4H 06A5H
Operational Interface :		Panel / Software	Communication
Default :		0x00000000	
Control Mode :		PR	
Unit :		-	
Range :		0x00000000 ~ 0xFFFFFFFF	
Data Size :		32-bit	
Format :		Hexadecimal	
Settings : Please refer to the description of P6-02.			

P6-83	PDATA41	PATH# 41Data	Address: 06A6H 06A7H
Operational Interface :		Panel / Software	Communication
Default :		0	
Control Mode :		PR	
Unit :		-	

Range :	-2147483648 ~ +2147483647
Data Size :	32-bit
Format :	Decimal
Settings :	Please refer to the description of P6-03.

<b>P6-84</b>	<b>PDEF42</b>	<b>PATH# 42</b>	<b>Definition</b>	<b>Address: 06A8H 06A9H</b>
	Operational Interface :	Panel / Software	Communication	Related Section: 7.10
	Default :	0x00000000		
	Control Mode :	PR		
	Unit :	-		
	Range :	0x00000000 ~ 0xFFFFFFFF		
	Data Size :	32-bit		
	Format :	Hexadecimal		
	Settings :	Please refer to the description of P6-02.		

<b>P6-85</b>	<b>PDAT42</b>	<b>PATH# 42</b>	<b>Data</b>	<b>Address: 06AAH 06ABH</b>
	Operational Interface :	Panel / Software	Communication	Related Section: 7.10
	Default :	0		
	Control Mode :	PR		
	Unit :	-		
	Range :	-2147483648 ~ +2147483647		
	Data Size :	32-bit		
	Format :	Decimal		
	Settings :	Please refer to the description of P6-03.		

<b>P6-86</b>	<b>PDEF43</b>	<b>PATH# 43Definition</b>		<b>Address: 06ACH 06ADH</b>
	Operational Interface :	Panel / Software	Communication	Related Section: 7.10
	Default :	0x00000000		
	Control Mode :	PR		
	Unit :	-		
	Range :	0x00000000 ~ 0xFFFFFFFF		
	Data Size :	32-bit		
	Format :	Hexadecimal		
Settings :	Please refer to the description of P6-02.			

<b>P6-87</b>	<b>PDAT43</b>	<b>PATH# 43Data</b>		<b>Address: 06AEH 06AFH</b>
	Operational Interface :	Panel / Software	Communication	Related Section: 7.10
	Default :	0		
	Control Mode :	PR		
	Unit :	-		
	Range :	-2147483648 ~ +2147483647		
	Data Size :	32-bit		
	Format :	Decimal		
Settings :	Please refer to the description of P6-03.			

<b>P6-88</b>	<b>PDEF44</b>	<b>PATH# 44Definition</b>		<b>Address: 06B0H 06B1H</b>
	Operational Interface :	Panel / Software	Communication	Related Section: 7.10
	Default :	0x00000000		
	Control Mode :	PR		
Unit :	-			



Range :	0x00000000 ~ 0xFFFFFFFF
Data Size :	32-bit
Format :	Hexadecimal
Settings :	Please refer to the description of P6-02.

<b>P6-89</b>	<b>PDAT44</b>	<b>PATH# 44Data</b>	<b>Address: 06B2H 06B3H</b>
	Operational Interface :	Panel / Software	Communication
	Default :	0	
	Control Mode :	PR	
	Unit :	-	
	Range :	-2147483648 ~ +2147483647	
	Data Size :	32-bit	
	Format :	Decimal	
	Settings :	Please refer to the description of P6-03.	

<b>P6-90</b>	<b>PDEF45</b>	<b>PATH# 45Definition</b>	<b>Address: 06B4H 06B5H</b>
	Operational Interface :	Panel / Software	Communication
	Default :	0x00000000	
	Control Mode :	PR	
	Unit :	-	
	Range :	0x00000000 ~ 0xFFFFFFFF	
	Data Size :	32-bit	
	Format :	Hexadecimal	
	Settings :	Please refer to the description of P6-02.	

<b>P6-91</b>	<b>PDAT45</b>	<b>PATH# 45Data</b>	<b>Address: 06B6H 06B7H</b>
	Operational Interface :	Panel / Software	Communication
	Default :	0	
	Control Mode :	PR	
	Unit :	-	
	Range :	-2147483648 ~ +2147483647	
	Data Size :	32-bit	
	Format :	Decimal	
	Settings :	Please refer to the description of P6-03.	

<b>P6-92</b>	<b>PDEF46</b>	<b>PATH# 46Definition</b>	<b>Address: 06B8H 06B9H</b>
	Operational Interface :	Panel / Software	Communication
	Default :	0x00000000	
	Control Mode :	PR	
	Unit :	-	
	Range :	0x00000000 ~ 0xFFFFFFFF	
	Data Size :	32-bit	
	Format :	Hexadecimal	
	Settings :	Please refer to the description of P6-02.	

<b>P6-93</b>	<b>PDAT46</b>	<b>PATH# 46Data</b>	<b>Address: 06BAH 06BBH</b>
	Operational Interface :	Panel / Software	Communication
	Default :	0	
	Control Mode :	PR	
	Unit :	-	

Range :	-2147483648 ~ +2147483647
Data Size :	32-bit
Format :	Decimal
Settings :	Please refer to the description of P6-03.

<b>P6-94</b>	<b>PDEF47</b>	<b>PATH# 47</b>	<b>Definition</b>	<b>Address: 06BCH 06BDH</b>
	Operational Interface :	Panel / Software	Communication	Related Section: 7.10
	Default :	0x00000000		
	Control Mode :	PR		
	Unit :	-		
	Range :	0x00000000 ~ 0xFFFFFFFF		
	Data Size :	32-bit		
	Format :	Hexadecimal		
	Settings :	Please refer to the description of P6-02.		

<b>P6-95</b>	<b>PDAT47</b>	<b>PATH# 47</b>	<b>Data</b>	<b>Address: 06BEH 06BFH</b>
	Operational Interface :	Panel / Software	Communication	Related Section: 7.10
	Default :	0		
	Control Mode :	PR		
	Unit :	-		
	Range :	-2147483648 ~ +2147483647		
	Data Size :	32-bit		
	Format :	Decimal		
	Settings :	Please refer to the description of P6-03.		

P6-96	PDEF48	PATH# 48	Definition	Address: 06C0H 06C1H
Operational Interface :		Panel / Software	Communication	Related Section: 7.10
Default :		0x00000000		
Control Mode :		PR		
Unit :		-		
Range :		0x00000000 ~ 0xFFFFFFFF		
Data Size :		32-bit		
Format :		Hexadecimal		
Settings : Please refer to the description of P6-02.				

P6-97	PDAT48	PATH# 48	Data	Address: 06C2H 06C3H
Operational Interface :		Panel / Software	Communication	Related Section: 7.10
Default :		0		
Control Mode :		PR		
Unit :		-		
Range :		-2147483648 ~ +2147483647		
Data Size :		32-bit		
Format :		Decimal		
Settings : Please refer to the description of P6-03.				

P6-98	PDEF49	PATH# 49	Definition	Address: 06C4H 06C5H
Operational Interface :		Panel / Software	Communication	Related Section: 7.10
Default :		0x00000000		
Control Mode :		PR		
Unit :		-		

Range :	0x00000000 ~ 0xFFFFFFFF
Data Size :	32-bit
Format :	Hexadecimal
Settings :	Please refer to the description of P6-02.

<b>P6-99</b>	<b>PDAT49</b>	<b>PATH# 49Data</b>	<b>Address: 06C6H 06C7H</b>
	Operational Interface :	Panel / Software	Communication
	Default :	0	
	Control Mode :	PR	
	Unit :	-	
	Range :	-2147483648 ~ +2147483647	
	Data Size :	32-bit	
	Format :	Decimal	
	Settings :	Please refer to the description of P6-03.	
			Related Section: 7.10

**P7-xx PR Parameters (Please refer to Chapter 7 for detailed setting)**

P7-00	PDEF50	PATH# 50 Definition	Address: 0700H 0701H
Operational Interface :		Panel / Software	Communication
Default :		0x00000000	
Control Mode :		PR	
Unit :		-	
Range :		0x00000000 ~ 0xFFFFFFFF	
Data Size :		32-bit	
Format :		Hexadecimal	
Settings : Please refer to the description of P6-02			



**NOTE** PATH (procedure)

P7-01	PDAT50	PATH# 50 Data	Address: 0702H 0703H
Operational Interface :		Panel / Software	Communication
Default :		0	
Control Mode :		PR	
Unit :		-	
Range :		-2147483648 ~ +2147483647	
Data Size :		32-bit	
Format :		Decimal	
Settings : Please refer to the description of P6-03.			

P7-02	PDEF51	PATH# 51 Definition	Address: 0704H 0705H
Operational Interface :		Panel / Software	Related Section: 7.10
		Communication	
Default :		0x00000000	
Control Mode :		PR	
Unit :		-	
Range :		0x00000000 ~ 0xFFFFFFFF	
Data Size :		32-bit	
Format :		Hexadecimal	
Settings : Please refer to the description of P6-02.			

P7-03	PDAT51	PATH# 51 Data	Address: 0706H 0707H
Operational Interface :		Panel / Software	Related Section: 7.10
		Communication	
Default :		0	
Control Mode :		PR	
Unit :		-	
Range :		-2147483648 ~ +2147483647	
Data Size :		32-bit	
Format :		Decimal	
Settings : Please refer to the description of P6-03.			

P7-04	PDEF52	PATH# 52 Definition	Address: 0708H 0709H
Operational Interface :		Panel / Software	Related Section: 7.10
		Communication	
Default :		0x00000000	
Control Mode :		PR	
Unit :		-	

Range :	0x00000000 ~ 0xFFFFFFFF
Data Size :	32-bit
Format :	HEXADECIMAL
Settings :	Please refer to the description of P6-02.

P7-05	PDAT52	PATH# 52 Data	Address: 070AH 070BH
Operational Interface :	Panel / Software	Communication	Related Section: 7.10
Default :	0		
Control Mode :	PR		
Unit :	-		
Range :	-2147483648 ~ +2147483647		
Data Size :	32-bit		
Format :	Decimal		
Settings :	Please refer to the description of P6-03.		

P7-06	PDEF53	PATH# 53 Definition	Address: 070CH 070DH
Operational Interface :	Panel / Software	Communication	Related Section: 7.10
Default :	0x00000000		
Control Mode :	PR		
Unit :	-		
Range :	0x00000000 ~ 0xFFFFFFFF		
Data Size :	32-bit		
Format :	Hexadecimal		
Settings :	Please refer to the description of P6-02.		



P7-07	PDAT53	PATH# 53 Data	Address: 070EH 070FH
Operational Interface :		Panel / Software	Communication
Default :		0	
Control Mode :		PR	
Unit :		-	
Range :		-2147483648 ~ +2147483647	
Data Size :		32-bit	
Format :		Decimal	
Settings : Please refer to the description of P6-03.			

P7-08	PDEF54	PATH# 54 Definition	Address: 0710H 0711H
Operational Interface :		Panel / Software	Communication
Default :		0x00000000	
Control Mode :		PR	
Unit :		-	
Range :		0x00000000 ~ 0xFFFFFFFF	
Data Size :		32-bit	
Format :		Hexadecimal	
Settings : Please refer to the description of P6-02.			

P7-09	PDAT54	PATH# 54 Data	Address: 0712H 0713H
Operational Interface :		Panel / Software	Communication
Default :		0	
Control Mode :		PR	
Unit :		-	

Range :	-2147483648 ~ +2147483647
Data Size :	32-bit
Format :	Decimal
Settings :	Please refer to the description of P6-03.

P7-10	PDEF55	PATH# 55 Definition	Address: 0714H 0715H
Operational Interface :		Panel / Software	Communication
Default :		0x00000000	
Control Mode :		PR	
Unit :		-	
Range :		0x00000000 ~ 0xFFFFFFFF	
Data Size :		32-bit	
Format :		Hexadecimal	
Settings :		Please refer to the description of P6-02.	
		Related Section: 7.10	

P7-11	PDAT55	PATH# 55 Data	Address: 0716H 0717H
Operational Interface :		Panel / Software	Communication
Default :		0	
Control Mode :		PR	
Unit :		-	
Range :		-2147483648 ~ +2147483647	
Data Size :		32-bit	
Format :		Decimal	
Settings :		Please refer to the description of P6-03.	
		Related Section: 7.10	

P7-12	PDEF56	PATH# 56 Definition	Address: 0718H 0719H
Operational Interface :		Panel / Software	Related Section: 7.10
		Communication	
Default :		0x00000000	
Control Mode :		PR	
Unit :		-	
Range :		0x00000000 ~ 0xFFFFFFFF	
Data Size :		32-bit	
Format :		Hexadecimal	
Settings : Please refer to the description of P6-02.			

P7-13	PDAT56	PATH# 56 Data	Address: 071AH 071BH
Operational Interface :		Panel / Software	Related Section: 7.10
		Communication	
Default :		0	
Control Mode :		PR	
Unit :		-	
Range :		-2147483648 ~ +2147483647	
Data Size :		32-bit	
Format :		Decimal	
Settings : Please refer to the description of P6-03.			

P7-14	PDEF57	PATH# 57 Definition	Address: 071CH 071DH
Operational Interface :		Panel / Software	Related Section: 7.10
		Communication	
Default :		0x00000000	
Control Mode :		PR	
Unit :		-	

Range :	0x00000000 ~ 0xFFFFFFFF
Data Size :	32-bit
Format :	Hexadecimal
Settings :	Please refer to the description of P6-02.

P7-15	PDAT57	PATH# 57 Data	Address: 071EH 071FH
Operational Interface :	Panel / Software	Communication	Related Section: 7.10
Default :	0		
Control Mode :	PR		
Unit :	-		
Range :	-2147483648 ~ +2147483647		
Data Size :	32-bit		
Format :	Decimal		
Settings :	Please refer to the description of P6-03.		

P7-16	PDEF58	PATH# 58 Definition	Address: 0720H 0721H
Operational Interface :	Panel / Software	Communication	Related Section: 7.10
Default :	0x00000000		
Control Mode :	PR		
Unit :	-		
Range :	0x00000000 ~ 0xFFFFFFFF		
Data Size :	32-bit		
Format :	Hexadecimal		
Settings :	Please refer to the description of P6-02.		

P7-17	PDAT58	PATH# 58 Data	Address: 0722H 0723H
Operational Interface :		Panel / Software	Communication
Default :		0	
Control Mode :		PR	
Unit :		-	
Range :		-2147483648 ~ +2147483647	
Data Size :		32-bit	
Format :		Decimal	
Settings : Please refer to the description of P6-03.			

P7-18	PDEF59	PATH# 59 Definition	Address: 0724H 0725H
Operational Interface :		Panel / Software	Communication
Default :		0x00000000	
Control Mode :		PR	
Unit :		-	
Range :		0x00000000 ~ 0xFFFFFFFF	
Data Size :		32-bit	
Format :		Hexadecimal	
Settings : Please refer to the description of P6-02.			

P7-19	PDAT59	PATH# 59 Data	Address: 0726H 0727H
Operational Interface :		Panel / Software	Communication
Default :		0	
Control Mode :		PR	
Unit :		-	

Range :	-2147483648 ~ +2147483647
Data Size :	32-bit
Format :	Decimal
Settings :	Please refer to the description of P6-03.

P7-20	PDEF60	PATH# 60 Definition	Address: 0728H 0729H
Operational Interface :		Panel / Software	Communication
Default :		0x00000000	
Control Mode :		PR	
Unit :		-	
Range :		0x00000000 ~ 0xFFFFFFFF	
Data Size :		32-bit	
Format :		Hexadecimal	
Settings :		Please refer to the description of P6-02.	
		Related Section: 7.10	

P7-21	PDAT60	PATH# 60 Data	Address: 072AH 072BH
Operational Interface :		Panel / Software	Communication
Default :		0	
Control Mode :		PR	
Unit :		-	
Range :		-2147483648 ~ +2147483647	
Data Size :		32-bit	
Format :		Decimal	
Settings :		Please refer to the description of P6-03.	
		Related Section: 7.10	

P7-22	PDEF61	PATH# 61 Definition	Address: 072CH 072DH
	Operational Interface :	Panel / Software      Communication	Related Section: 7.10
	Default :	0x00000000	
	Control Mode :	PR	
	Unit :	-	
	Range :	0x00000000 ~ 0xFFFFFFFF	
	Data Size :	32-bit	
	Format :	Hexadecimal	
	Settings :	Please refer to the description of P6-02.	

P7-23	PDAT61	PATH# 61 Data	Address: 072EH 072FH
	Operational Interface :	Panel / Software      Communication	Related Section: 7.10
	Default :	0	
	Control Mode :	PR	
	Unit :	-	
	Range :	-2147483648 ~ +2147483647	
	Data Size :	32-bit	
	Format :	Decimal	
	Settings :	Please refer to the description of P6-03.	

P7-24	PDEF62	PATH# 62 Definition	Address: 0730H 0731H
	Operational Interface :	Panel / Software      Communication	Related Section: 7.10
	Default :	0x00000000	
	Control Mode :	PR	
	Unit :	-	

Range :	0x00000000 ~ 0xFFFFFFFF
Data Size :	32-bit
Format :	Hexadecimal
Settings :	Please refer to the description of P6-02.

P7-25	PDAT62	PATH# 62 Data	Address: 0732H 0733H
Operational Interface :	Panel / Software	Communication	Related Section: 7.10
Default :	0		
Control Mode :	PR		
Unit :	-		
Range :	-2147483648 ~ +2147483647		
Data Size :	32-bit		
Format :	Decimal		
Settings :	Please refer to the description of P6-03.		

P7-26	PDEF63	PATH# 63 Definition	Address: 0734H 0735H
Operational Interface :	Panel / Software	Communication	Related Section: 7.10
Default :	0x00000000		
Control Mode :	PR		
Unit :	-		
Range :	0x00000000 ~ 0xFFFFFFFF		
Data Size :	32-bit		
Format :	Hexadecimal		
Settings :	Please refer to the description of P6-02.		



<b>P7-27</b>	<b>PDAT63</b>	<b>PATH# 63 Data</b>		<b>Address: 0736H 0737H</b>
	Operational Interface :	Panel / Software	Communication	Related Section: 7.10
	Default :	0		
	Control Mode :	PR		
	Unit :	-		
	Range :	-2147483648 ~ +2147483647		
	Data Size :	32-bit		
	Format :	Decimal		
	Settings :	Please refer to the description of P6-03.		

**Table 8.1 Function Description of Digital Input (DI)**

Setting Value: 0x01			
DI Name	Function Description of Digital Input (DI)	Trigger Method	Control Mode
SON	When this DI is On, servo is activated (Servo On)	Level triggered	ALL

Setting Value: 0x02			
DI Name	Function Description of Digital Input (DI)	Trigger Method	Control Mode
ARST	After the alarm has been cleared, when the DI is ON the drive will show that the alarm has been cleared.	Rising edge triggered	ALL

Setting Value: 0x03			
DI Name	Function Description of Digital Input (DI)	Trigger Method	Control Mode
GAINUP	In speed and position mode, when the DI is ON (P2-27 should be set to 1), the gain switched to the one multiplies the switching rate.	Level triggered	PT, PR, S

Setting Value: 0x04			
DI Name	Function Description of Digital Input (DI)	Trigger Method	Control Mode
CCLR	Clear the pulse counter and the setting of parameter P2-50. 0: clear the position pulse deviation (It is suitable in PT mode). When DI is ON, the accumulative pulse deviation of the drive will be cleared to 0.	Rising edge triggered, Level triggered	PT, PR

Setting Value: 0x05			
DI Name	Function Description of Digital Input (DI)	Trigger Method	Control Mode
ZCLAMP	When the speed is slower than the setting of zero speed (P1-38), if the DI is ON, the motor stops running.	Level triggered	S

Setting Value: 0x06			
DI Name	Function Description of Digital Input (DI)	Trigger Method	Control Mode
CMDINV	In speed mode, when the DI is ON, the input command will be in reverse direction.	Level triggered	S

Setting Value: 0x07			
DI Name	Function Description of Digital Input (DI)	Trigger Method	Control Mode
Reserved			

Setting Value: 0x08			
DI Name	Function Description of Digital Input (DI)	Trigger Method	Control Mode
CTRG	In PR mode, after selecting the PR command (POS0 ~ 5), when the DI is ON, the motor will rotate according to the command issued by the register.	Rising edge triggered	PR

Setting Value: 0x09			
DI Name	Function Description of Digital Input (DI)	Trigger Method	Control Mode
TRQLM	In speed and position mode, when the DI is ON, the motor torque will be limited, and the limited torque command will be internal register or analog voltage command.	Level triggered	PT, PR, S

Setting Value: 0x0A			
DI Name	Function Description of Digital Input (DI)	Trigger Method	Control Mode
GTRY	When gantry control function is enabled (P1-74 = 2), if it needs to temporarily disable this function, turn on DI.GTRY will do. And the axis that received the command from DI.GTRY no longer calculates the error between two axes.	Rising edge triggered	PT

Setting Value: 0x0C			
DI Name	Function Description of Digital Input (DI)	Trigger Method	Control Mode
VPL	Latch function of analog position command. When this DI is ON, the motor will be held on the current position. During the time of DI ON, the motor will not operate even when there is any change of analog command. When this DI is OFF, the motor will complete the command during the time the DI is triggered.	Level triggered	PT/PR Full-closed loop

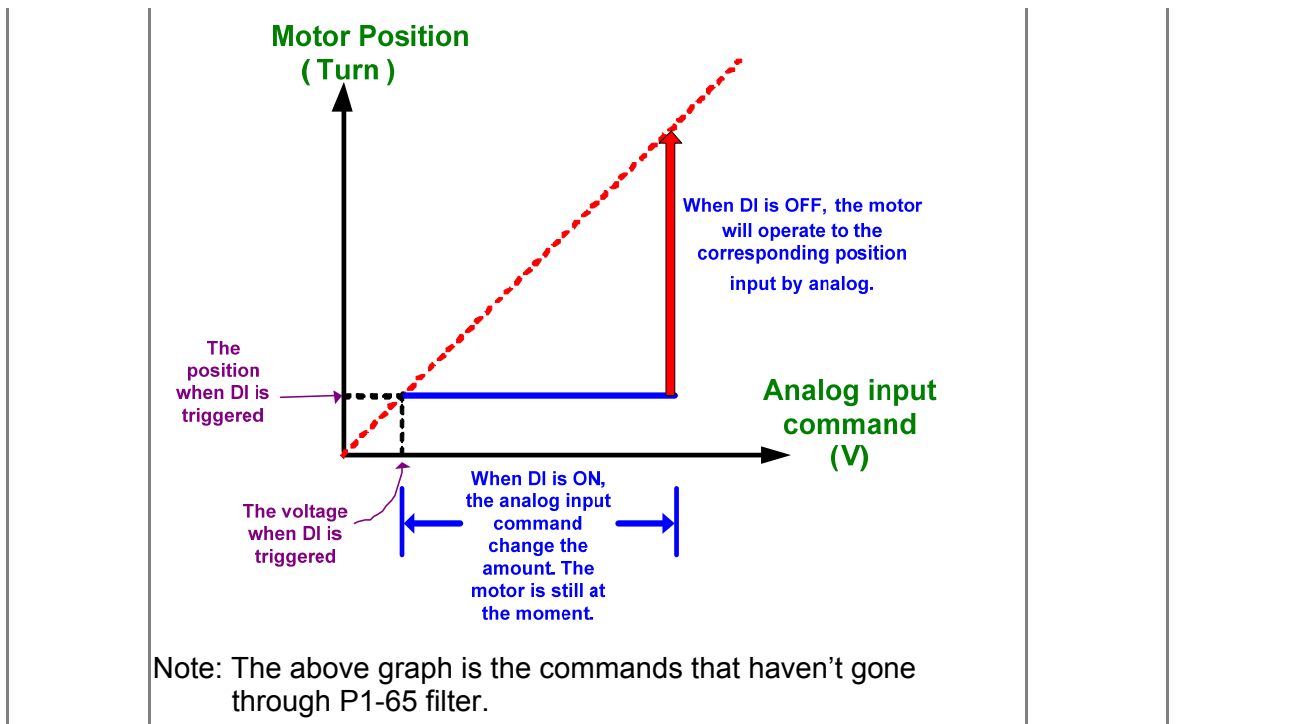

Setting Value: 0x0D			
DI Name	Function Description of Digital Input (DI)	Trigger Method	Control Mode
VPRS	<p>Clear function of analog position command</p> <p>When this DI is ON, the motor will be held in the current position.</p> <p>Despite the change of analog command during the time of DI ON, the motor will still stay in the current position even when the DI is OFF. However, the position the motor stays will correspond to the new analog command. Thus, the coordinate system of the motor will be redefined.</p> <p><b>Motor position (Turn)</b></p> <p><b>Analog input command (V)</b></p> <p>The position when DI is triggered</p> <p>The voltage when DI is triggered</p> <p>When DI is ON, all input command is invalid.</p> <p>When DI is OFF, the motor stands still, but its coordinate will be redefined.</p>	Rising edge triggered	PT/PR Full-closed loop

**Setting Value: 0x10**

DI Name	Function Description of Digital Input (DI)	Trigger Method	Control Mode
SPDLM	In torque mode, when the DI is ON, the motor speed will be limited, the limited speed command will be internal register or analog voltage command.	Level triggered	T

**Setting Value: 0x11, 0x12, 0x13, 0x1A, 0x1B, 0x1C**

DI Name	Function Description of Digital Input (DI)	Trigger Method	Control Mode						
POS0	PR Command Selection (1~64)	Level triggered	PR						
POS1	Position Command								
POS2	POS5								
POS3	POS4								
POS4	POS3								
POS5	POS2								
	POS1								
	POS0								
	CTRG								
	Corresponding Parameter								
	Homing	0	0	0	0	0	0	↑	P6-00
	Procedure1	0	0	0	0	0	1	↑	P6-01
	~								P6-02
	Procedure 50	1	1	0	0	1	0	↑	P6-03
	Procedure 51	1	1	0	0	1	1	↑	P6-98
	~								P6-99
	Procedure 63	1	1	1	1	1	1	↑	P7-00
									P7-01
									P7-26
									P7-27

**Setting Value: 0x1D**

DI Name	Function Description of Digital Input (DI)	Trigger Method	Control Mode
ABSE	When DI.ABSE is ON, it is in ABS mode. DI.ABSQ, DI.ABSC, DI.ABSR, DI.ABSD and DI.ABSC are enabled. When DI.ABSE is ON, the function of DI4, DO2, and DO3 will be disabled. Function of DI4 will be ASDQ, DO2 will be ABSR and DO3 will be ABSD.	Level triggered	ALL

**Setting Value: 0x1F**

DI Name	Function Description of Digital Input (DI)	Trigger Method	Control Mode
ABSC	When DI.ABSC is ON, multi-turn data stored in absolute encoder will be cleared. When DI.ABSE is ON, this function is enabled.	Rising edge triggered	ALL

**Setting Value: When DI.ABSE is ON, DI4 inputs ABSQ signal, function set by P2-13 is disabled.**

DI Name	Function Description of Digital Input (DI)	Trigger Method	Control Mode
ABSQ is always inputted by DI4	During I/O transmission, Handshaking signal will be sent to the servo drive by the controller. When DI.ABSQ is OFF, it means the controller issues Request ; DI.ABSQ is ON means the controller has already received ABSQ signal. When DI.ABSE is ON, this DI is enabled. Please refer to diagram 12.4 for detailed description.	Rising and Falling edge triggered	ALL

**Setting Value: 0x14, 0x15**

DI Name	Function Description of Digital Input (DI)					Trigger Method	Control Mode		
SPD0 SPD1	Internal Speed Command Selection (1~4)					Level triggered	S		
	Speed Command Number	DI signal of CN1		Command	Content			Range	
	S1	0	0	S	External analog command			Voltage deviation between V-REF and GND	+/- 10V
				Sz	N/A			Speed command is 0	
	S2	0	1	Register Parameter				P1-09	+/-5000 r/min
	S3	1	0					P1-10	+/-5000 r/min
	S4	1	1					P1-11	+/- 5000 r/min

**Setting Value: 0x16, 0x17**

DI Name	Function Description of Digital Input (DI)					Trigger Method	Control Mode		
TCM0 TCM1	Internal Torque Command Selection (1~4)					Level triggered	T		
	Torque Command Number	DI signal of CN1		Command	Content			Range	
	T1	0	0	T	External analog command			Voltage deviation between T-REF and GND	+/- 10V
				Tz	N/A			Torque command is 0	
	T2	0	1	Register Parameter				P1-12	+/- 300 %
	T3	1	0					P1-13	+/- 300 %
	T4	1	1					P1-14	+/- 300 %

**Setting Value: 0x18**

DI Name	Function Description of Digital Input (DI)	Trigger Method	Control Mode
S-P	In position and speed mode, if the DI is OFF, it is in speed mode. And it is in position mode when the DI is ON. (P selects PT or PR via DI.PT-PR (0x2B).)	Level triggered	Dual Mode

**Setting Value: 0x19**

DI Name	Function Description of Digital Input (DI)	Trigger Method	Control Mode
S-T	In speed and torque mode, if the DI is OFF, it is in speed mode. And it is in torque mode when the DI is ON.	Level triggered	Dual Mode

**Setting Value: 0x20**

DI Name	Function Description of Digital Input (DI)	Trigger Method	Control Mode
T-P	In position and torque mode, if the DI is OFF, it is in torque mode; if the DI is ON, then it is in position mode.	Level triggered	Dual Mode

**Setting Value: 0x21**

DI Name	Function Description of Digital Input (DI)	Trigger Method	Control Mode
EMGS	When this DI is ON, the motor stops urgently.	Level triggered	ALL

**Setting Value: 0x22**

DI Name	Function Description of Digital Input (DI)	Trigger Method	Control Mode
NL (CWL)	Reverse inhibit limit (contact b)	Level triggered	ALL

**Setting Value: 0x23**

DI Name	Function Description of Digital Input (DI)	Trigger Method	Control Mode
PL (CCWL)	Forward inhibit limit (contact b)	Level triggered	ALL

Setting Value: 0x24			
DI Name	Function Description of Digital Input (DI)	Trigger Method	Control Mode
ORGP	In PR mode, during the process of homing if the DI is ON $\leftrightarrow$ OFF, the servo will regard this position as the homing origin. (Please refer to the setting of parameter P5-04)	Rising / Falling edge triggered	PR

Setting Value: 0x27			
DI Name	Function Description of Digital Input (DI)	Trigger Method	Control Mode
SHOM	In PR mode, when searching the origin is needed, it will activate the function of searching the origin when the DI is ON. (Please refer to the setting of parameter P5-04)	Rising edge triggered	PR

Setting Value: 0x2B			
DI Name	Function Description of Digital Input (DI)	Trigger Method	Control Mode
PT-PR	When selecting PT-PR dual mode or PT-PR-S multiple mode, source can be selected via this DI. If this DI is OFF, it is in PT mode; If the DI is ON, it is in PR mode.	Level triggered	Dual Mode

Setting Value: 0x36			
DI Name	Function Description of Digital Input (DI)	Trigger Method	Control Mode
CAM	E-Cam engaging control (Please refer to the setting of P5-88 U, Z value)	Rising / Falling edge triggered	PR

Setting Value: 0x37			
DI Name	Function Description of Digital Input (DI)	Trigger Method	Control Mode
JOGU	When this DI is ON, the motor will JOG in forward direction.	Level triggered	ALL

Setting Value: 0x38			
DI Name	Function Description of Digital Input (DI)	Trigger Method	Control Mode
JOGD	When this DI is on, the motor will JOG in reverse direction.	Level triggered	ALL



Setting Value: 0x39			
DI Name	Function Description of Digital Input (DI)	Trigger Method	Control Mode
EV1	Event trigger command #1 (Refer to the setting of P5-98, P5-99)	Rising /Falling edge triggered	PR

Setting Value: 0x3A			
DI Name	Function Description of Digital Input (DI)	Trigger Method	Control Mode
EV2	Event trigger command #2 (Refer to the setting of P5-98, P5-99)	Rising /Falling edge triggered	PR

Setting Value: 0x3B			
DI Name	Function Description of Digital Input (DI)	Trigger Method	Control Mode
EV3	Event trigger command #3 (It is provided after firmware version V1.008 sub04.)	Rising /Falling edge triggered	PR

Setting Value: 0x3C			
DI Name	Function Description of Digital Input (DI)	Trigger Method	Control Mode
EV4	Event trigger command #4 (It is provided after firmware version V1.008 sub04)	Rising /Falling edge triggered	PR

Setting Value: 0x43, 0x44			
DI Name	Function Description of Digital Input (DI)	Trigger Method	Control Mode
GNUM0 GNUM1	Gear Ratio Selection 0 (Numerator) Gear Ratio Selection 1 (Numerator) <div style="text-align: center; margin-top: 10px;"> <pre>                     graph LR                         Pulse --&gt; NumeratorBox                         subgraph NumeratorBox [GNUM0, GNUM1]                             N1[1st Numerator (N1) (P1-44)]                             N2[2nd Numerator (N2) (P2-60)]                             N3[3rd Numerator (N3) (P2-61)]                             N4[4th Numerator (N4) (P2-62)]                             Den[Denominator (P1-45)]                         end                         NumeratorBox --&gt; MF[Moving Filter (P1-68)]                         MF --&gt; SF[Smooth Filter (P1-08)]                         FB[Feed Back Pulse] --&gt; Sum(( ))                         SF --&gt; Sum                         Sum --&gt; PE[Pulse Error]                     </pre> </div>	Level triggered	PT

**Setting Value: 0x45**

DI Name	Function Description of Digital Input (DI)	Trigger Method	Control Mode
INHP	In position mode, when this DI is ON, the external pulse input command is not working. (Note: The function has to be set to DI8 so as to ensure the instantaneity of pulse prohibition)	Level triggered	PT

**Setting Value: 0x46**

DI Name	Function Description of Digital Input (DI)	Trigger Method	Control Mode
STOP	Motor stops	Rising edge triggered	PR

**Setting Value: 0x47**

DI Name	Function Description of Digital Input (DI)	Trigger Method	Control Mode
PFQS	This DI can be used to stop the emergency stop of deceleration time. The setting of deceleration time is identical to P5-03. When DI.PFQS is on, AL35F will occur. Then, motor starts to decelerate. When the speed reaches 0, AL3CF occurs and servo is off. Please turn on DI.ARST to servo on the drive again.	Rising edge triggered	PT,PR,T,S

**NOTE**

- 1 ) 11 ~ 17 Single control modes; 18~20 Dual control mode.
- 2 ) When P2-10 ~ P2-17 is set to 0, DI has no function.

**Table 8.2 Function Description of Digital Output (DO)**

Setting Value: 0x01			
DO Name	Function Description of Digital Output (DO)	Trigger Method	Control Mode
SRDY	When the controlled and main circuit power is applied to the drive, this DO is ON if no alarm occurs.	Level triggered	ALL

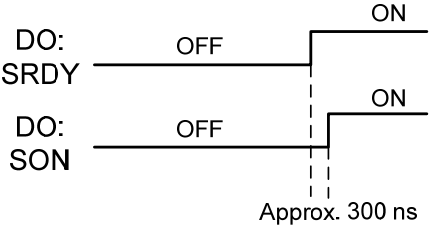
Setting Value: 0x02			
DO Name	Function Description of Digital Output (DO)	Trigger Method	Control Mode
SON	<p>When the servo is ON, this DO is ON if no alarm occurs.</p> <p>As soon as it applies to the power, when it is automatically Servo On, the time difference between DO:SRDY and DO:SON</p> 	Level triggered	ALL

Setting Value: 0x03			
DO Name	Function Description of Digital Output (DO)	Trigger Method	Control Mode
ZSPD	When the motor speed is slower than the setting speed of zero speed (P1-38), this DO is ON.	Level triggered	ALL

Setting Value: 0x04			
DO Name	Function Description of Digital Output (DO)	Trigger Method	Control Mode
TSPD	When the motor speed is faster than the target speed (P1-39), this DO is ON.	Level triggered	ALL

Setting Value: 0x05			
DO Name	Function Description of Digital Output (DO)	Trigger Method	Control Mode
TPOS	<p>In position mode, when the deviation pulse number is smaller than the position range (the setting value of P1-54), this DO is ON.</p> <p>When the drive is in PR mode, this DO is ON when the position error between target position and current position is smaller than the setting value (value of P1-54).</p>	Level triggered	PT, PR

Setting Value: 0x06			
DO Name	Function Description of Digital Output (DO)	Trigger Method	Control Mode
TQL	When it is in torque limit, this DO is ON.	Level triggered	ALL , except T, Tz

Setting Value: 0x07			
DO Name	Function Description of Digital Output (DO)	Trigger Method	Control Mode
ALRM	When the alarm occurs, this DO is ON. (Except DO: 0x11 (forward / reverse limit, communication error, under voltage))	Level triggered	ALL

Setting Value: 0x08			
DO Name	Function Description of Digital Output (DO)	Trigger Method	Control Mode
BRKR	<p>When the signal of brake control is output, adjust the setting of parameter P1-42 and P1-43.</p> <p>The diagram shows two digital signals, SON and BRKR, and a motor speed signal. SON and BRKR are both ON during a period labeled 'ON' between MBT1(P1-42) and MBT2(P1-43). Motor speed ramps up and then down, with ZSPD (P1-38) marked at the end of the ramp. Vertical dashed lines indicate the timing of MBT1 and MBT2.</p>	Level triggered	ALL

Setting Value: 0x09			
DO Name	Function Description of Digital Output (DO)	Trigger Method	Control Mode
HOME	<p>When homing is completed, it means the position coordinates system is available and this DO is ON.</p> <p>When applying to the power, this DO is OFF. When homing is completed, this DO is ON. During the operation, this DO is ON until the counter overflows (including command or feedback) and the DO becomes OFF.</p> <p>When PR triggers homing command, this DO becomes OFF. After homing, this DO becomes ON.</p>	Level triggered	PR

Setting Value: 0x0D		
DO Name	Function Description of Digital Output (DO)	Control Mode
ABSW	Warning of absolute encoder.	ALL

Setting Value: 0x0E		
DO Name	Function Description of Digital Output (DO)	Control Mode
IDXD	Indexing coordinates is valid.	PR

Setting Value: 0x10			
DO Name	Function Description of Digital Output (DO)	Trigger Method	Control Mode
OLW	<p>When reaching the overload setting, this DO is ON.</p> <p><math>t_{OL}</math> = Overload allowable time of the servo x Setting value of P1-56, when the overload accumulative time exceeds <math>t_{OL}</math>, it will output pre-overload warning (OLW). However, if the overload accumulative time exceeds the overload allowable time of the servo, it will output pre-overload error (ALRM).</p> <p>For example:            The setting value of pre-overload warning is 60% (P1-56=60).            When the output average load of the servo drive is 200%, if the output time exceeds 8 seconds, the servo drive will show the overload alarm (AL.006).</p> <p><math>t_{OL}</math> = The output average load of the servo exceeds 200% for 8 seconds x parameter setting value = 8sec x 60% = 4.8sec            Result: When the output average load of the servo drive exceeds 200% for 4.8 seconds, this DO is ON. If it exceeds for 8 seconds, then, DO.ALRM is ON.</p>	Level triggered	ALL

Setting Value: 0x11			
DO Name	Function Description of Digital Output (DO)	Trigger Method	Control Mode
WARN	Warning output (Forward / reverse limit, emergency stop, communication error, under voltage)	Level triggered	ALL

Setting Value: 0x12			
DO Name	Function Description of Digital Output (DO)	Trigger Method	Control Mode
OVF	Position Command /Feedback Overflows	Level triggered	PR

Setting Value: 0x13			
DO Name	Function Description of Digital Output (DO)	Trigger Method	Control Mode
SNL (SCWL)	Software limit (Reverse limit)	Level triggered	ALL

<b>Setting Value: 0x14</b>			
DO Name	Function Description of Digital Output (DO)	Trigger Method	Control Mode
SPL (SCCWL)	Software limit (Forward limit)	Level triggered	ALL

<b>Setting Value: 0x15</b>			
DO Name	Function Description of Digital Output (DO)	Trigger Method	Control Mode
Cmd_OK	Complete PR command and enter into PR mode, this DO is ON. When PR command is executing, this DO is OFF. After completing the command, this DO is ON. When the DO is ON, it means the command is completed, but not finishing motor positioning. Please refer to DO.TPOS.	Level triggered	PR

<b>Setting Value: 0x16</b>			
DO Name	Function Description of Digital Output (DO)	Trigger Method	Control Mode
CAP_OK	CAP procedure completed	Level triggered	ALL

<b>Setting Value: 0x17</b>			
DO Name	Function Description of Digital Output (DO)	Trigger Method	Control Mode
MC_OK	When DO.Cmd_OK and TPOS are both ON, this DO is ON. Refer to P1-48.	Level triggered	PR

<b>Setting Value: 0x18</b>			
DO Name	Function Description of Digital Output (DO)	Trigger Method	Control Mode
CAM_AREA	Master of E-Cam locates in setting area. A2L does not support E-Cam function.	Level triggered	PR

<b>Setting Value: 0x19</b>			
DO Name	Function Description of Digital Output (DO)	Trigger Method	Control Mode
SP_OK	Speed completed output: In speed mode, when the deviation between the speed feedback and the command is smaller than the setting value of P1-47, then this DO is ON.	Level triggered	S / Sz

<b>Setting Value: 0x2C</b>		
DO Name	Function Description of Digital Output (DO)	Control Mode
Zon1	When the value which is monitored by P0-09 is between P0-54 ~ P0-55, then this DO is ON.	ALL

**Setting Value: When DI.ABSE is ON, DO2 outputs ABSR signal, function set by P2-19 is disabled.**

DO Name	Function Description of Digital Output (DO)	Trigger Method	Control Mode
ABSR is always outputted by DO2	DO.ABSR is OFF means the Request sent by ABSQ has been received. DO.ABSR is ON means the data that is outputted by ABSD is valid. When DI.ABSE is ON, this DO is enabled. Please refer to diagram 12.4 for detailed description.	Level triggered	ALL

**Setting Value: When DI.ABSE is ON, DO3 outputs ABSD signal, function set by P2-20 is disabled.**

DO Name	Function Description of Digital Output (DO)	Trigger Method	Control Mode
ABSD is always outputted by DO3	Position data of ABS is outputted. The data is valid when ABSR is ON. When DI.ABSE is ON, this DO is enabled. Please refer to diagram 13.4 for detailed description.	Level triggered	ALL

**Setting Value: 0x30**

DO Name	Function Description of Digital Output (DO)	Trigger Method	Control Mode
SDO_0	Output the status of bit 00 of P4-06	Level triggered	ALL

**Setting Value: 0x31**

DO Name	Function Description of Digital Output (DO)	Trigger Method	Control Mode
SDO_1	Output the status of bit 01 of P4-06	Level triggered	ALL

**Setting Value: 0x32**

DO Name	Function Description of Digital Output (DO)	Trigger Method	Control Mode
SDO_2	Output the status of bit 02 of P4-06	Level triggered	ALL

<b>Setting Value: 0x33</b>			
DO Name	Function Description of Digital Output (DO)	Trigger Method	Control Mode
SDO_3	Output the status of bit 03 of P4-06	Level triggered	ALL

<b>Setting Value: 0x34</b>			
DO Name	Function Description of Digital Output (DO)	Trigger Method	Control Mode
SDO_4	Output the status of bit 04 of P4-06	Level triggered	ALL

<b>Setting Value: 0x35</b>			
DO Name	Function Description of Digital Output (DO)	Trigger Method	Control Mode
SDO_5	Output the status of bit 05 of P4-06	Level triggered	ALL

<b>Setting Value: 0x36</b>			
DO Name	Function Description of Digital Output (DO)	Trigger Method	Control Mode
SDO_6	Output the status of bit 06 of P4-06	Level triggered	ALL

<b>Setting Value: 0x37</b>			
DO Name	Function Description of Digital Output (DO)	Trigger Method	Control Mode
SDO_7	Output the status of bit 07 of P4-06	Level triggered	ALL

<b>Setting Value: 0x38</b>			
DO Name	Function Description of Digital Output (DO)	Trigger Method	Control Mode
SDO_8	Output the status of bit 08 of P4-06	Level triggered	ALL

<b>Setting Value: 0x39</b>			
DO Name	Function Description of Digital Output (DO)	Trigger Method	Control Mode
SDO_9	Output the status of bit 09 of P4-06	Level triggered	ALL



Setting Value: 0x3A			
DO Name	Function Description of Digital Output (DO)	Trigger Method	Control Mode
SDO_A	Output the status of bit 10 of P4-06	Level triggered	ALL

Setting Value: 0x3B			
DO Name	Function Description of Digital Output (DO)	Trigger Method	Control Mode
SDO_B	Output the status of bit 11 of P4-06	Level triggered	ALL

Setting Value: 0x3C			
DO Name	Function Description of Digital Output (DO)	Trigger Method	Control Mode
SDO_C	Output the status of bit 12 of P4-06	Level triggered	ALL

Setting Value: 0x3D			
DO Name	Function Description of Digital Output (DO)	Trigger Method	Control Mode
SDO_D	Output the status of bit 13 of P4-06	Level triggered	ALL

Setting Value: 0x3E			
DO Name	Function Description of Digital Output (DO)	Trigger Method	Control Mode
SDO_E	Output the status of bit 14 of P4-06	Level triggered	ALL

Setting Value: 0x3F			
DO Name	Function Description of Digital Output (DO)	Trigger Method	Control Mode
SDO_F	Output the status of bit 15 of P4-06	Level triggered	ALL

**NOTE**

1) When P2-18 ~ P2-22 is set to 0, DO has no function.

# Chapter 9 Communications

## 9.1 RS-485 & RS-232 Communication Hardware Interface

This servo drive supports the serial communication of RS-485 and RS-232. Communication function enables the servo drive to access and change parameters inside the system. However, RS-485 and RS-232 cannot be used at the same time. Parameter P3-05 can use RS-485 and RS-232 as the communication protocol. Followings are the wiring description.

### RS-232

■ Configuration

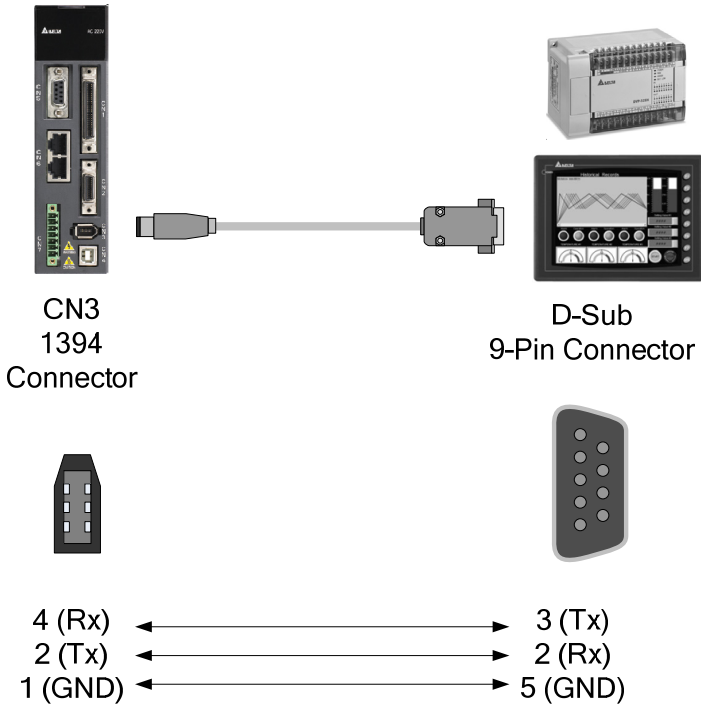

**NOTE**

- 1) 15-meter communication cable is suitable for less interference environment. If the transmission speed is over 38400bps, the length of communication cable should be shorter than 3 meters so as to ensure the accuracy of transmission.
- 2) Numbers shown in the above diagram represent the pin number of each connector.

## RS-485

### ■ Configuration

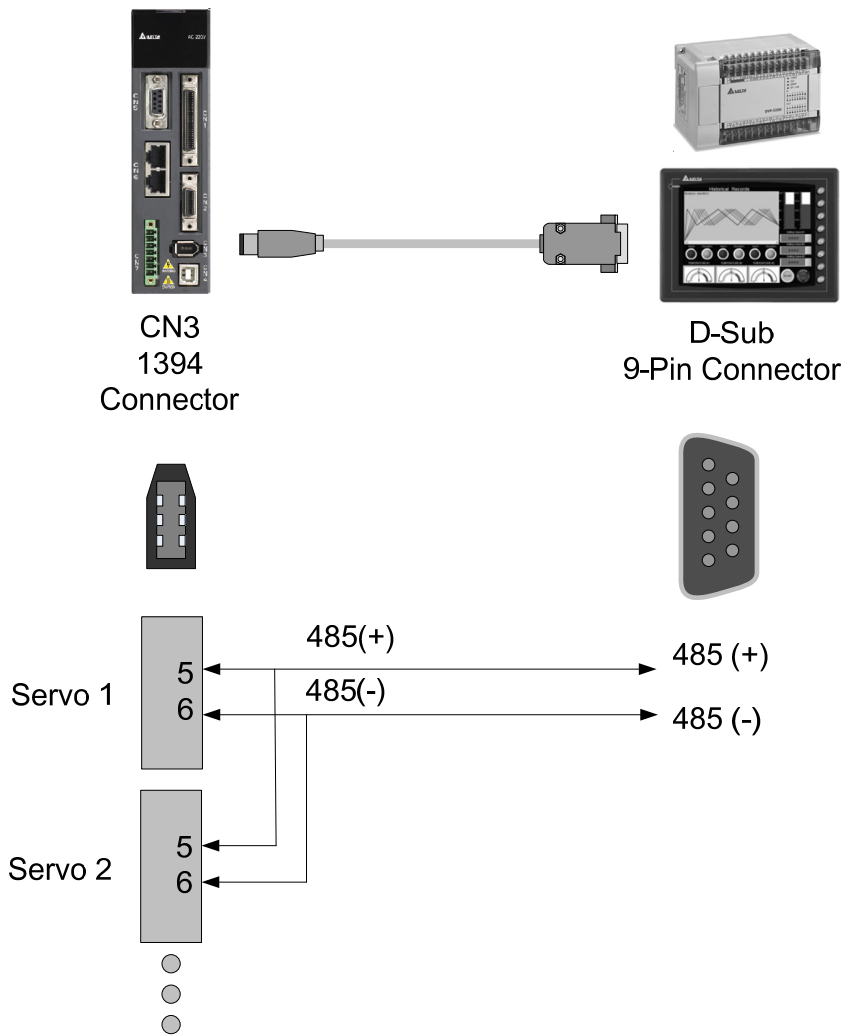

### NOTE

- 1) 100 meters of communication cable is suitable for less interference environment. If the transmission speed is over 38400bps, the length of communication cable should not longer than 15 meters so as to ensure the accuracy of transmission.
- 2) Numbers shown in the above diagram represent the pin number of each connector.
- 3) Please use the power supply unit whose direct current is over 12 volt.
- 4) Using RS-485 can connect up to 32 servo drives at the same time. REPEATER can be used to connect more servo drives. 127 is the maximum.
- 5) Please refer to Chapter 3.6 for CN3 Pin Definition.

## 9.2 RS-485 / RS-232 Communication Parameters Setting

The following four parameters, P3-00 (Address Setting), P3-01 (Transmission Speed), P3-02 (Communication Protocol) and P3-05 (Communication Mechanism), are essential and must be set for the communication of the servo drive. The rest, such as P3-03 (Communication Error Disposal), P3-04 (Communication Timeout), P3-06 (Control Switch of Digital Input), P3-07 (Communication Response Delay Time) and P3-08 (Monitor Mode) is optional. Please refer to Chapter 8 of this user manual.

P3-00●	ADR	Address Setting	Address: 0300H 0301H
Operational Interface :	Panel / Software	Communication	Related Section: 9.2
Default :	0x7F		
Control Mode :	ALL		
Unit :	-		
Range :	0x01 ~ 0x7F		
Data Size :	16-bit		
Format :	Hexadecimal		
Settings :	The communication address setting is divided into Y, X (hexadecimal):		

	0	0	Y	X
Range	-	-	0 ~ 7	0 ~ F

When using RS-232/RS-485 to communicate, one servo drive can only set one address. The duplicate address setting will cause abnormal communication.

This address represents the absolute address of the servo drive in communication network. It is also applicable to RS-232/485 and CAN bus.

When the communication address setting of MODBUS is set to 0xFF, the servo drive will automatically reply and receive data regardless of the address. However, P3-00 cannot be set to 0xFF.

<b>P3-01</b>	<b>BRT</b>	<b>Transmission Speed</b>	<b>Address: 0302H 0303H</b>
--------------	------------	---------------------------	---------------------------------

Operational Interface : Panel / Software      Communication      Related Section: 9.2

Default : 0x0203

Control Mode : ALL

Unit : bps

Range : 0x0000 ~ 0x0405

Data Size : 16-bit

Format : Hexadecimal

Settings : The setting of transmission speed is divided into Z, Y, X (hexadecimal):

	0	Z	Y	X
Communication Port	-	CAN	-	RS-232/485
Range	0	0~4	0	0~5

- Definition of X setting value
  - 0: 4800
  - 1: 9600
  - 2: 19200
  - 3: 38400
  - 4: 57600
  - 5: 115200
- Definition of Z setting value
  - 0: 125 Kbit/s
  - 1: 250 Kbit/s
  - 2: 500 Kbit/s
  - 3: 750 Kbit/s
  - 4: 1.0 Mbit/s



**NOTE**

- 1) If this parameter is set via CAN, only Z can be set and the others remain.
- 2) The communication speed of USB is 1.0 Mbit/s only and is unchangeable.

P3-02	PTL	Communication Protocol	Address: 0304H 0305H
Operational Interface :		Panel / Software	Communication
Default :		6	
Control Mode :		ALL	
Unit :		-	
Range :		0 ~ 0x8	
Data Size :		16-bit	
Format :		Hexadecimal	
Settings : The definition of the setting value is as the followings: 0: 7, N, 2 (MODBUS, ASCII) 1: 7, E, 1 (MODBUS, ASCII) 2: 7, O, 1 (MODBUS, ASCII) 3: 8, N, 2 (MODBUS, ASCII) 4: 8, E, 1 (MODBUS, ASCII) 5: 8, O, 1 (MODBUS, ASCII) 6: 8, N, 2 (MODBUS, RTU) 7: 8, E, 1 (MODBUS, RTU) 8: 8, O, 1 (MODBUS, RTU)			

P3-05	CMM	Communication Mechanism	Address: 030AH 030BH
Operational Interface :		Panel / Software	Communication
Default :		0	
Control Mode :		ALL	
Unit :		-	
Range :		0x00 ~ 0x01	
Data Size :		16-bit	
Format :		Hexadecimal	
Settings : Communication port can select one or more than one communications. <ul style="list-style-type: none"> <li>● Communication Interface</li> <li>0: RS232</li> <li>1: RS485</li> </ul>			

## 9.3 MODBUS Communication Protocol

There are two modes of MODBUS networks communication, ASCII (American Standard Code for information interchange) mode and RTU (Remote Terminal Unit) mode. Users could set the needed communication protocol via parameter P3-02. Apart from these two communication modes, this servo drive also supports function of 03H to access more than one data, 06H to write one character and 10H to write multiple characters. Please refer to the following descriptions.

### ■ Code Description

#### ASCII Mode:

The so-called ASCII mode is using American Standard Code for Information Interchange (ASCII) to transmit the data. Between two stations (Master and Slave) to transmit data 64H, the master will send '6' which represented by 36H of ASCII code and '4' represented by 34H of ASCII code.

ASCII code of digit 0 to 9 and characters A to F is as follows:

Character	'0'	'1'	'2'	'3'	'4'	'5'	'6'	'7'
ASCII code	30H	31H	32H	33H	34H	35H	36H	37H
Character	'8'	'9'	'A'	'B'	'C'	'D'	'E'	'F'
ASCII code	38H	39H	41H	42H	43H	44H	45H	46H

#### RTU Mode:

Every 8-bit of data is constituted by two 4-bits hexadecimal characters. If data 64H is transmitted between two stations, it will be transmitted directly, which is more efficient than ASCII mode.

### ■ Character Structure

Characters will be encoded into the following framing and transmitted in serial. The checking method of different bit is as the following.

10-bit character frame (For 7-bit character)

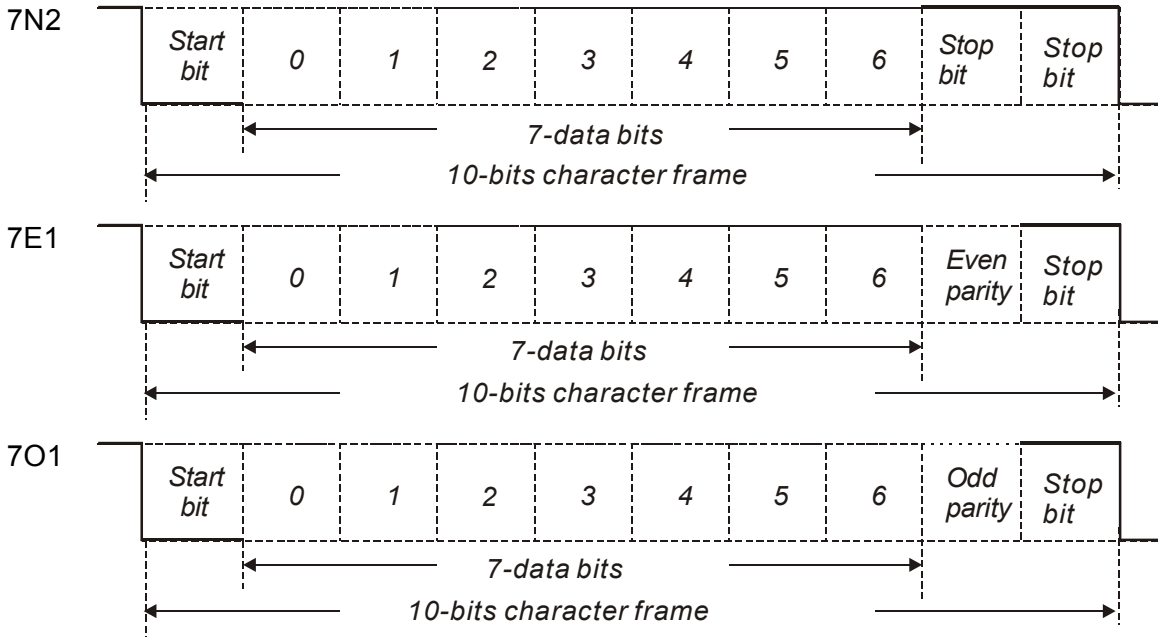

11-bit character frame (For 8-bit character)

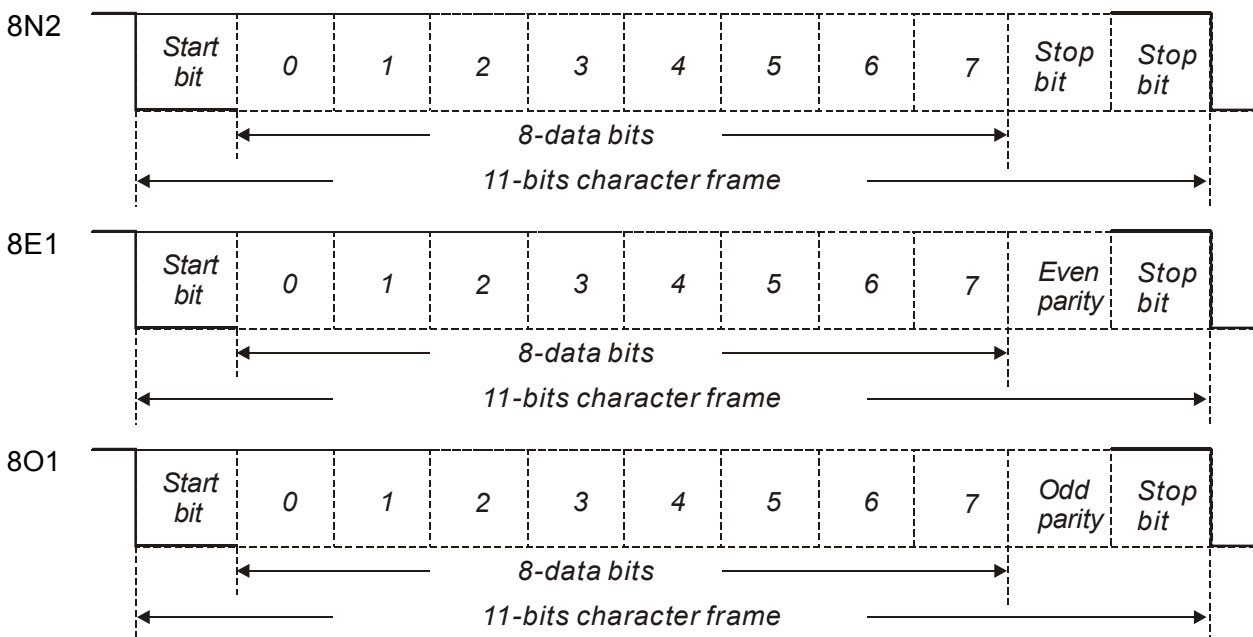



## ■ Communication Data Structure

### ASCII Mode:

Start	Start character ': ' (3AH)
Slave Address	Communication address: 1-byte consists of 2 ASCII codes
Function	Function code: 1-byte consists of 2 ASCII codes
Data (n-1)	Data content: n-word = 2n-byte includes 4n of ASCII code, $n \leq 10$
.....	
Data (0)	
LRC	Error checking: 1-byte consists of 2 ASCII codes
End 1	End code 1: (0DH)(CR)
End 0	End code 0: (0AH)(LF)

The start character of communication in ASCII mode is colon ' : ' (ASCII is 3AH), ADR is the ASCII code of two characters. The end code is CR (Carriage Return) and LF (Line Feed). And the communication address, function code, data content, error checking LRC (Longitudinal Redundancy Check), etc are between the start character and end code.

### RTU Mode:

Start	A silent interval of more than 10ms
Slave Address	Communication address: 1-byte
Function	Function code: 1-byte
Data (n-1)	Data content : n-word = 2n-byte · $n \leq 10$
.....	
Data (0)	
CRC	Error checking: 2-byte
End 1	A silent interval of more than 10ms

The start of communication in RTU (Remote Terminal Unit) mode is a silent interval. The end of it is another silent interval. The communication address, function code, data content, error checking CRC (Cyclical Redundancy Check), etc are between the start and the end.

Example 1: function code 03H, access multiple words:

The Master issues the command to the 1<sup>st</sup> Slave and reads the continuous 2 words starting from the start address 0200H. In response message from the Slave, the content of starting address 0200H is 00B1H and the content of the 2<sup>nd</sup> data address 0201H is 1F40H. The maximum allowable data in one single access is 10. The calculation of LRC and CRC will be described in next chapter.

### ASCII Mode:

#### Command message (Master):

Start	‘.’
Slave Address	‘0’
	‘1’
Function	‘0’
	‘3’
Starting data address	‘0’
	‘2’
	‘0’
	‘0’
Number of data (In Word)	‘0’
	‘0’
	‘0’
	‘2’
LRC Check	‘F’
	‘8’
End 1	(0DH)(CR)
End 0	(0AH)(LF)

#### Response message (Slave):

Start	‘.’
Slave Address	‘0’
	‘1’
Function	‘0’
	‘3’
Number of data (In Byte)	‘0’
	‘4’
Content of starting data address 0200H	‘0’
	‘0’
	‘B’
Content of second data address 0201H	‘1’
	‘F’
	‘4’
LRC Check	‘0’
	‘E’
End 1	(0DH)(CR)
End 0	(0AH)(LF)

**RTU Mode:****Command message (Master):**

Slave Address	01H
Function	03H
Starting data address	02H (High)
	00H (Low)
Number of data (In Word)	00H
	02H
CRC Check Low	C5H (Low)
CRC Check High	B3H (High)

**Response message (Slave):**

Slave Address	01H
Function	03H
Number of data (In Byte)	04H
Content of starting data address 0200H	00H (High)
	B1H (Low)
Content of second data address 0201H	1FH (High)
	40H (Low)
CRC Check Low	A3H (Low)
CRC Check High	D4H (High)

Please note:

Before and after the transmission in RTU mode, 10ms of silent interval is needed.

Example 2: function code 06H, write single word:

The Master issues command to the 1<sup>st</sup> Slave and writes data 0064H to address 0200H. The Slave sends the response message to the Master after the writing is completed. The calculation of LRC and CRC will be described in next chapter.

### ASCII Mode:

#### Command message (Master):

Start	‘.’
Slave Address	‘0’
	‘1’
Function	‘0’
	‘6’
Starting data address	‘0’
	‘2’
	‘0’
	‘0’
Data content	‘0’
	‘0’
	‘6’
	‘4’
LRC Check	‘9’
	‘3’
End 1	(0DH)(CR)
End 0	(0AH)(LF)

#### Response message (Slave):

Start	‘.’
Slave Address	‘0’
	‘1’
Function	‘0’
	‘6’
Starting data address	‘0’
	‘2’
	‘0’
	‘0’
Data content	‘0’
	‘0’
	‘6’
	‘4’
LRC Check	‘9’
	‘3’
End 1	(0DH)(CR)
End 0	(0AH)(LF)

### RTU Mode:

#### Command message (Master):

Address	01H
Slave Function	06H
Starting data address	02H (High)
	00H (Low)
Data content	00H (High)
	64H (Low)
CRC Check Low	89H (Low)
CRC Check High	99H (High)

#### Response message (Slave):

Address	01H
Slave Function	06H
Starting data address	02H (High)
	00H (Low)
Data content	00H (High)
	64H (Low)
CRC Check Low	89H (Low)
CRC Check High	99H (High)

Please note:

Before and after the transmission in RTU mode, 10ms of silent interval is needed.

Example 3: function code 10H, write multiple words:

The Master issues command to the 1<sup>st</sup> Slave and writes 0BB8H and 0000H to the starting address 0112H. That is to say, 0112H is written into 0BB8H and 0113H is written into 0000H. The maximum allowable data in one single access is 10. The Slave sends the response message to the Master after the writing is completed. The calculation of LRC and CRC will be described in next chapter.

### ASCII Mode:

#### Command message (Master):

Start	‘.’
Slave Address	‘0’
	‘1’
Function	‘1’
	‘0’
Starting data address	‘0’
	‘1’
	‘1’
	‘2’
Number of data (In Word)	‘0’
	‘0’
	‘0’
	‘2’
Number of data (In Byte)	‘0’
	‘4’
The first data content	‘0’
	‘B’
	‘B’
The second data content	‘8’
	‘0’
	‘0’
	‘0’
LRC Check	‘1’
	‘3’
End 1	(0DH)(CR)
End 0	(0AH)(LF)

#### Response message (Slave):

Start	‘.’
Slave Address	‘0’
	‘1’
Function	‘1’
	‘0’
Starting data address	‘0’
	‘1’
	‘1’
	‘2’
Number of data	‘0’
	‘0’
	‘0’
	‘2’
LRC Check	‘D’
	‘A’
End 1	(0DH)(CR)
End 0	(0AH)(LF)

**RTU Mode:****Command message (Master):**

Slave Address	01H
Function	10H
Starting data address	01H (High)
	12H (Low)
Number of data (In Word)	00H (High)
	02H (Low)
Number of data (In Byte)	04H
The first data content	0BH (High)
	B8H (Low)
The second data content	00H (High)
	00H (Low)
CRC Check Low	FCH (Low)
CRC Check High	EBH (High)

**Response message (Slave):**

Slave Address	01H
Function	10H
Starting data address	01H (High)
	12H (Low)
Number of data (In Word)	00H (High)
	02H (Low)
CRC Check Low	E0H (Low)
CRC Check High	31H (High)

Please note:

Before and after the transmission in RTU mode, 10ms of silent interval is needed.

## ■ LRC and CRC transmission Error Checking

The error checking in ASCII communication mode is LRC (Longitudinal Redundancy Check); CRC (Cyclical Redundancy Check) is for RTU communication mode. The algorithm of both is as the following.

LRC (ASCII mode):

Start	'.'
Slave address	'7'
	'F'
Function	'0'
	'3'
Starting data address	'0'
	'5'
	'C'
	'4'
Number of data	'0'
	'0'
	'0'
	'1'
LRC Check	'B'
	'4'
End 1	(0DH)(CR)
End 0	(0AH)(LF)

The LRC algorithm is: add all byte, round down the carry and take 2' s complement. For example,  $7FH + 03H + 05H + C4H + 00H + 01H = 14CH$ , round down carry 1 and take 4CH.

2's complement of 4CH is B4H.

**CRC (RTU Mode):**

The description of CRC is as the followings:

- Step 1: Load a 16-bits register of FFFFH, which is called **CRC** register.
- Step 2: (The low byte of CRC register) XOR (The first byte of command), and save the result in CRC register.
- Step 3: Right move one bit. Check the least significant bit (LSB) of CRC register. If the bit is 1, then (CRC register) XOR (A001H).
- Step 4: Return to Step 3 until Step 3 has been executed for 8 times. Go to Step 5.
- Step 5: Repeat the procedure from Step 2 to Step 4 until all byte is processing. Get the result of CRC value.

Description: After calculating CRC value, fill in the low word of CRC first in command message, and then fill in the high word of CRC. For example, if the result of CRC algorithm is 3794H, fill in 94H in low word and then 37H in high word.

ADR	01H
CMD	03H
Starting data address	01H (High)
	01H (Low)
Number of data (In Word)	00H (High)
	02H (Low)
CRC Check Low	94H (Low)
CRC Check High	37H (High)



**Example of CRC program:**

Produce CRC in C language. This function needs two parameters:

unsigned char\* data;

unsigned char length

The function returns the CRC value as a type of unsigned integer.

```

unsigned int crc_chk(unsigned char* data, unsigned char length) {
    int j;
    unsigned int reg_crc=0xFFFF;

    while( length-- ) {
        reg_crc^= *data++;
        for (j=0; j<8; j++ ) {
            if( reg_crc & 0x01 ) { /*LSB(bit 0 ) = 1 */
                reg_crc = (reg_crc >> 1)^0xA001;
            } else {
                reg_crc = (reg_crc>>1);
            }
        }
    }
    return reg_crc;
}

```

PC communication program example:

```

#include<stdio.h>
#include<dos.h>
#include<conio.h>
#include<process.h>
#define PORT 0x03F8      /* the address of COM 1 */
#define THR 0x0000
#define RDR 0x0000
#define BRDL 0x0000
#define IER 0x0001
#define BRDH 0x0001
#define LCR 0x0003
#define MCR 0x0004
#define LSR 0x0005
#define MSR 0x0006
unsigned char rdat[60];
/* read 2 data from address 0200H of ASD with address 1 */
unsigned char tdat[60]={':','0','1','0','3','0','2','0','0','0','0','0','2','F','8','\r','\n'};

```

```

void main() {
int I;
outportb(PORT+MCR,0x08);          /* interrupt enable */
outportb(PORT+IER,0x01);          /* interrupt as data in */
outportb(PORT+LCR,( inportb(PORT+LCR) | 0x80 ) );
/* the BRDL/BRDH can be access as LCR.b7 == 1 */
outportb(PORT+BRDL,12);
outportb(PORT+BRDH,0x00);
outportb(PORT+LCR,0x06);          /* set prorocol
                                   <7,E,1> = 1AH,          <7,O,1> = 0AH
                                   <8,N,2> = 07H          <8,E,1> = 1BH
                                   <8,O,1> = 0BH          */

for( I = 0; I<=16; I++ ) {
    while( !(inportb(PORT+LSR) & 0x20) ); /* wait until THR empty */
    outportb(PORT+THR,tdat[I]);          /* send data to THR */
}
I = 0;
while( !kbhit() ) {
    if( inportb(PORT+LSR)&0x01 ) { /* b0==1, read data ready */
        rdat[I++] = inportb(PORT+RDR); /* read data from RDR */
    }
}
}
}

```

## 9.4 Write-in and Read-out Communication Parameters

Please refer to Chapter 8, Parameters for all parameter details. And the descriptions of parameters which can be wrote or read through communication are as follows.

Parameters are divided into 8 groups, Group 0: Monitor Parameters, Group 1: Basic Parameters, Group 2: Extension Parameters, Group 3: Communication Parameters, Group 4: Diagnosis Parameters, Group 5: Motion Setting, Group 6 and Group 7: PR Definition.

### Write parameters via communication:

Parameters which can be written through communication include:

Group 0, except (P0-00~P0-01), (P0-08~P0-13) and (P0-46) Group 1 (P1-00~P1-76)

Group 2 (P2-00~P2-67)

Group 3 (P3-00~P3-11)

Group 4, except (P4-00~P4-04) and (P4-08~P4-09)

Group 5 (P5-00~P5-99), except P5-10, P5-16 and P5-76

Group 6 (P6-00~P6-99)

Group 7 (P7-00~P7-27)

### Please note that:

(P3-01) When change to a new communication speed, the next data will be written in a new transmission speed after setting the new value.

(P3-02) When change to the new communication protocol, the next data will be written with the new communication protocol after setting the new value.

(P4-05) JOG controls parameters of the servo. Please refer to Chapter 8, Parameters for the description.

(P4-06) Force to control output contact. This parameter is for DO (Digital Output) testing. Users can write 1, 2, 4, 8 and 16 to test DO1, DO2, DO3, DO4 and DO5 respectively. Please write 0 after the test so as to inform the servo drive that the test has been completed.

(P4-10) Adjustment function selection. Write 20 (= 14H in hexadecimal format) in parameter P2-08 first to enable the adjustment so as to change the value of P4-10.

(P4-11 ~ P4-21) This parameter is Offset Adjustment. Do not change the setting unless it is necessary. If it is necessary, please write 22 (= 16H, in hexadecimal format) in parameter P2-08 first to enable the function so as to change the value of (P4-11 ~ P4-21)

### Read parameters through communication:

Parameters can be read through communication include:

Group 0 (P0-00~P0-46)

Group 4 (P4-00~P4-23)

Group 1 (P1-00~P1-76)

Group 5 (P5-00~P5-99)

Group 2 (P2-00~P2-67)

Group 6 (P6-00~P6-99)

Group 3 (P3-00~P3-11)

Group 7 (P7-00~P7-27)

# Chapter 10 Troubleshooting

## 10.1 Alarm of Servo Drive

Display	Alarm Name	Alarm Description	Corresponding DO	Servo Status
<b>AL001</b>	Over current	The current of the main circuit is 1.5 times more than the instantaneous current of the motor.	ALM	Servo Off
<b>AL002</b>	Over voltage	The voltage of the main circuit is higher than the standard voltage.	ALM	Servo Off
<b>AL003</b>	Under voltage	The voltage of the main circuit is lower than the standard voltage.	WARN	Servo Off
<b>AL004</b>	Motor Combination Error	The drive corresponds to the wrong motor.	ALM	Servo Off
<b>AL005</b>	Regeneration Error	Regeneration control is in error.	ALM	Servo Off
<b>AL006</b>	Overload	The motor and the drive is overload.	ALM	Servo Off
<b>AL007</b>	Over speed	The control speed of the motor exceeds the normal speed.	ALM	Servo Off
<b>AL008</b>	Abnormal Pulse Command	The input frequency of the pulse command is over the allowable value of the hardware interface.	ALM	Servo Off
<b>AL009</b>	Excessive Deviation of Position Command	The deviation of position command exceeds the allowable setting value.	ALM	Servo Off
<b>AL011</b>	Encoder Error	The encoder produces abnormal pulse.	ALM	Servo Off
<b>AL012</b>	Adjustment Error	When executing electrical adjustment, the adjusted value exceeds the allowable value.	ALM	Servo Off
<b>AL013</b>	Emergency Stop	Press the emergency stop button.	WARN	Servo Off
<b>AL014</b>	Reverse Limit Error	Activate the reverse limit switch.	WARN	Servo On
<b>AL015</b>	Forward Limit Error	Activate the forward limit switch.	WARN	Servo On
<b>AL016</b>	IGBT Overheat	The temperature of IGBT is over high	ALM	Servo Off

Display	Alarm Name	Alarm Description	Corresponding DO	Servo Status
<b>AL017</b>	Abnormal EEPROM	It is in error when DSP accesses EEPROM.	ALM	Servo Off
<b>AL018</b>	Abnormal signal output	The encoder output exceeds the rated output frequency.	ALM	Servo Off
<b>AL019</b>	Serial Communication Error	RS-232/485 communication is in error	ALM	Servo Off
<b>AL020</b>	Serial Communication Time Out	RS-232/485 communication time out	WARN	Servo On
<b>AL022</b>	Main Circuit Power Lack Phase	Only one single phase is inputted in the main circuit power.	WARN	Servo Off
<b>AL023</b>	Early Warning for Overload	Early Warning for Overload	WARN	Servo On
<b>AL024</b>	Encoder initial magnetic field error	The magnetic field of the encoder U, V, W signal is in error.	ALM	Servo Off
<b>AL025</b>	The Internal of the Encoder is in Error	The internal memory of the encoder and the internal counter are in error.	ALM	Servo Off
<b>AL026</b>	Unreliable internal data of the encoder	The error of the internal data has been detected for three times continuously.	ALM	Servo Off
<b>AL027</b>	The Internal of the Motor is in Error	The internal reset of the encoder is in error.	ALM	Servo On
<b>AL028</b>	Encoder voltage error or the internal of the encoder is in error	Charging circuit of the servo drive is not removed and the battery voltage is higher than the specification (>3.8 V) or the encoder signal is in error.	ALM	Servo On
<b>AL029</b>	Gray code error	Absolute position is in error.	ALM	Servo On
<b>AL030</b>	Motor Crash Error	The motor crashes the equipment, reaches the torque of P1-57 and exceeds the time set by P1-58.	ALM	Servo Off
<b>AL031</b>	Incorrect wiring of the motor power line U, V, W, GND	Incorrect wiring of the motor power line U, V, W, GND or the connection between both is breakdown.	ALM	Servo Off
<b>AL034</b>	Internal communication of the encoder is in error	1. Internal communication error of the absolute encoder 2. Internal error of other type of encoder	ALM	Servo Off
<b>AL035</b>	Encoder	Encoder temperature exceeds the	ALM	Servo

Display	Alarm Name	Alarm Description	Corresponding DO	Servo Status
	temperature exceeds the protective range	protective range		Off
<b>AL040</b>	Excessive Deviation of Full Closed-loop Position Control	Excessive Deviation of Full Closed-loop Position Control	ALM	Servo Off
<b>AL041</b>	Communication of CN5 is breakdown	Communication of CN5 (encoder) is breakdown	ALM	Servo Off
<b>AL042</b>	Analog input voltage error	The analog voltage is over than the setting value of P1-83.	ALM	Servo Off
<b>AL044</b>	Warning of servo drive function overload	When the servo drive function overloads, it might bring the abnormality of motion control, such as PR or E-Cam.	WARN	Servo On
<b>AL045</b>	Wrong setting of E-gear ratio	The setting of E-gear ratio exceeds the range (1/50~25600). Thus, when re-power on the servo drive, an alarm occurs.	ALM	Servo off
<b>AL060</b>	The absolute position is lost	Due to battery undervoltage or the failure of power supply, the encoder lost the internal record.	WARN	Servo On
<b>AL061</b>	Encoder under voltage	The voltage of the absolute encoder is lower than the specification	WARN	Servo On
<b>AL062</b>	The multi-turn of absolute encoder overflows	The multi-turn of absolute encoder exceeds the maximum range: -32768 ~ +32767	WARN	Servo On
<b>AL067</b>	Encoder temperature warning	Encoder temperature exceeds the warning level. (But it is still within the protective range.)	WARN	N/A
<b>AL068</b>	Absolute data transmitted via I/O is in error	The sequence is wrong when reading the absolute position via DIO.	WARN	Servo On
<b>AL069</b>	Wrong motor type	Incremental motor is not allowed to activate the absolute function.	ALM	Servo Off
<b>AL06A</b>	The absolute coordinate has not been initialized	The possible causes might be: 1. The motor is used for the first time 2. The battery had run dry but has replaced a new one.	WARN	Servo On
<b>AL070</b>	Encoder does not complete the command which is issued by servo drive	Servo drive has not completely writing barcode into encoder or the encoder does not complete the command issued by servo drive.	WARN	Servo Off
<b>AL083</b>	Servo drive	When the output current from servo	ALM	Servo

Display	Alarm Name	Alarm Description	Corresponding DO	Servo Status
	outputs excessive current	drive exceeds the setting level, ALE083 will be triggered to protect IGBT. This could avoid IGBT to be burned out because of the excessive current.		Off
<b>AL085</b>	The absolute coordinate has not been initialized	The possible causes might be: 1. The motor is used for the first time 2. The battery had run dry but has replaced a new one.	WARN	Servo On
<b>AL095</b>	The servo drive does not connect to external regenerative resistor	The servo drive does not connect to external regenerative resistor *This alarm is only for 5.5 kW and 7.5 kW.	WARN	Servo On
<b>AL099</b>	DSP Firmware Upgrade	EEPROM has not been reset after upgrading the firmware. The fault can be cleared when firstly set P2-08 to 30. Then set P2-08 to 28. And re-power on the drive.	ALM	Servo Off

## 10.2 Alarm of CANopen Communication

Display	Alarm Name	Alarm Description	Corrective Actions	Corresponding DO	Servo Status
<b>AL111</b>	CANopen SDO receives buffer overflow	SDO Rx Buffer overflow (receives more than two SDOs within 1 millisecond)	NMT: Reset node or 0x6040.Fault Reset	ALM	Servo On
<b>AL112</b>	CANopen PDO receives buffer overflow	PDO Rx Buffer overflow (receives more than two same PDOs of the COBID within 1 millisecond)	Same as above	ALM	Servo On
<b>AL121</b>	Index error occurs when accessing CANopen PDO	The specified Index in the message does not exist.	Same as above	ALM	Servo On
<b>AL122</b>	Sub-Index error occurs when accessing CANopen PDO	The specified Sub-Index in the message does not exist.	Same as above	ALM	Servo On
<b>AL123</b>	Data Size error occurs when accessing CANopen PDO	The data length in the message does not match to the specified object.	Same as above	ALM	Servo On
<b>AL124</b>	Data range error occurs when accessing CANopen PDO	The data value in the message is over the range of the specified object.	Same as above	ALM	Servo On
<b>AL125</b>	CANopen PDO is read-only and write-protected	The specified object in the message is write-protected.	Same as above	ALM	Servo On
<b>AL126</b>	CANopen PDO is not allowed in PDO	The specified object in the message does not support PDO	Same as above	ALM	Servo On
<b>AL127</b>	CANopen PDO is write-protected when Servo On	The specified object in the message is write-protected when Servo ON	Same as above	ALM	Servo On
<b>AL128</b>	Error occurs when reading CANopen PDO via EEPROM	An error occurs when loading the default value via ROM at start-up. All objects of CAN returns to the default value automatically.	Same as above	ALM	Servo On



Display	Alarm Name	Alarm Description	Corrective Actions	Corresponding DO	Servo Status
<b>AL129</b>	Error occurs when writing CANopen PDO via EEPROM	An error occurs when saving the current value into ROM.	Same as above	ALM	Servo On
<b>AL130</b>	The accessing address of EEPROM is out of range when using CANopen PDO.	The quantity of the data inside ROM is over the planned space. It is probably because the software has been updated. The data inside ROM is stored by the old version. Thus, it cannot be used.	Same as above	ALM	Servo On
<b>AL131</b>	CRC of EEPROM calculation error occurs when using CANopen PDO	It indicates that the data stored in ROM has been damaged. All objects of CAN will return to the default setting automatically.	Same as above	ALM	Servo On
<b>AL132</b>	Enter the incorrect password when using CANopen PDO	When entering parameters via CAN, the parameters are password-protected. Users have to decode the password first.	Same as above	ALM	Servo On
<b>AL170</b>	Heartbeat or NodeGuarding error	Heartbeat or NodeGuarding error	Same as above	WARN	On
<b>AL180</b>	Heartbeat or NodeGuarding error	Heartbeat or NodeGuarding error	Same as above	ALM	On
<b>AL185</b>	Abnormal CAN Bus hardware	The communication of CAN Bus is breakdown or Error Rx/Tx Counter is over 128.	NMT: Reset node or re-servo on	ALM	Servo On
<b>AL186</b>	CAN Bus off	CAN data transmission error	-	ALM	On
<b>AL130</b>	The accessing address of EEPROM is out of range when using CANopen PDO.	The quantity of the data inside ROM is over the planned space. It is probably because the software has been updated. The data inside ROM is stored by the old version. Thus, it cannot be used.	Same as above	ALM	Servo On

### 10.3 Alarm of Motion Control

Display	Alarm Name	Alarm Description	Corrective Actions	Corresponding DO	Servo Status
<b>AL201</b>	An error occurs when loading CANopen data	An error occurs when loading data via EEPROM.	DI.ARST, CANopen 0x1011 Restore default parameter	WARN	Servo On
<b>AL207</b>	Parameter group of PR#8 is out of range	The group of PR#8 command source, P_Grp exceeds the range.	DI.ARST, CANopen 0x1011 Restore default parameter	WARN	Servo On
<b>AL209</b>	The parameter number of PR#8 is out of range	Parameter number P_Idx of PR#8 command exceeds the range.	DI.ARST, CANopen 0x1011 Restore default parameter	WARN	Servo On
<b>AL213</b>	The parameter setting of PR#8 is wrong	Write parameters via PR #8: the value is over the range. Please refer to Chapter 7 for detailed description.	DI.Alm Reset or P0-01= 0	WARN	Servo On
<b>AL215</b>	Write parameters: read-only	Write parameters via PR procedure: the parameter is read-only	DI.Alm Reset or P0-01= 0	WARN	Servo On
<b>AL217</b>	Write parameters: parameter locked	Write parameters via PR procedure: it is write-protected when the servo is ON or the input data is unreasonable.	Correct the PR command and parameter	WARN	Servo On
<b>AL231</b>	The setting of monitor item of PR#8 is out of range	The setting of monitor item of PR#8, Sys_Var exceeds the range.	DI.ARST, CANopen 0x1011 Restore default parameter	WARN	Servo On
<b>AL235</b>	PR command overflows	Feedback position counter overflows and executes the absolute positioning command.	NMT: Reset node or 0x6040.Fault Reset	WARN	Servo On

Display	Alarm Name	Alarm Description	Corrective Actions	Corresponding DO	Servo Status
<b>AL237</b>	Indexing coordinate is undefined	When executing indexing function, if the index positioning command is directly executing before defining the start point of index coordinate, the alarm will therefore occur.	DI.Alm Reset or write 0 into P0-01	WARN	Servo On
<b>AL261 ~ AL277</b>	Reserved				
<b>AL283</b>	Forward Software Limit	The value of position command is bigger than forward software limit (P5-08)	The fault will be cleared automatically when the motor operates backwards.	WARN	Servo On
<b>AL285</b>	Reverse Software Limit	The value of position command is smaller than reverse software limit (P5-09)	The fault will be cleared automatically when the motor operates backwards.	WARN	Servo On
<b>AL289</b>	Feedback position counter overflows	Feedback position counter overflows.	NMT: Reset node or 0x6040.Fault Reset	WARN	Servo On
<b>AL291</b>	Servo OFF error	Servo OFF when the motion path is incomplete.	Same as above	WARN	Servo On
<b>AL301</b>	CANopen fails to synchronize	CANopen IP mode fails to synchronize with the controller.	Same as above	WARN	Servo On
<b>AL302</b>	The synchronized signal of CANopen is sent too fast	The synchronized signal, SYNC of CANopen is sent too fast.	Same as above	WARN	Servo On

Display	Alarm Name	Alarm Description	Corrective Actions	Corresponding DO	Servo Status
<b>AL303</b>	The synchronized signal of CANopen is sent too slow	The synchronized signal, SYNC of CANopen has not been received in time.	Same as above	WARN	Servo On
<b>AL304</b>	CANopen IP command is failed	Command cannot be issued in CANopen IP mode.	Same as above	WARN	Servo On
<b>AL305</b>	SYNC Period is in error	CANopen 301 Obj 0x1006 Data Error !	Same as above	WARN	Servo On
<b>AL380</b>	Position Deviation Alarm	Please refer to the description of parameter P1-48. After DO.MC_OK ON, DO.MC_OK becomes OFF because DO.TPOS turns OFF.	DI.Alm Reset or P0-01= 0	WARN	Servo On
<b>AL400</b>	Index coordinates error	The setting value of P2-52 is set too small and cause index coordinates error	Adjust the value of P2-52 to the appropriate one	ALM	Off
<b>AL401</b>	NMT Reset command is received when Servo On	NMT Reset command is received when Servo On	NMT:Reset node or 0x6040.Fault Reset	ALM	Off
<b>AL404</b>	Value of PR special filter setting is too big	The setting value of P1-22 causes inner position error overflows	Re-adjust the value of P1-22 until it is appropriate	ALM	Off
<b>AL555</b>	System Failure	DSP processing error	N/A		Do not Switch

**NOTE**

If the alarm occurs and is different from the alarm showed in **Alarm of Servo Drive**, **Alarm of CANopen Communication** and **Alarm of Motion Control**, please contact with distributors or technical personnel.

## 10.4 Causes and Corrective Actions

### Alarm Display

#### AL001 : Over current

Causes	Checking Method	Corrective Actions
The drive output is short-circuit	Check if the wiring between the motor and the drive is correct and see if the wire is short-circuited.	Eliminate short-circuit and avoid metal conductor being exposed.
The motor wiring is in error.	Check if the wiring steps are correct when connecting the motor to the drive.	Rewiring by following the wiring description from the user manual.
IGBT is abnormal	The temperature of the heat sink is abnormal	Send the drive back to the distributors or contact with Delta
The control parameter setting is in error.	Check if the setting value exceeds the default setting	Setting back to the default setting and then gradually adjust the value.
Unreasonable command	Check if the command doing reasonable acceleration time.	Less steep command used or filter applying to smooth command.

#### AL002 : Over voltage

Causes	Checking Method	Corrective Actions
The input voltage of the main circuit is higher than the rated allowable voltage.	Use the voltmeter to see if the input voltage of the main circuit is within the rated allowable voltage value. (please refer to Chapter 12.1)	Apply to the correct power supply or serial voltage regulator.
Wrong power input (incorrect power system)	Use the voltmeter to see if the power system matches the specification.	Apply to the correct power supply or serial adaptor.
The hardware of the servo drive is damaged.	Use the voltmeter to see if the input voltage of the main circuit is within the rated allowable voltage value but still shows the error.	Send the drive back to the distributors or contact with Delta.

#### AL003 : Under voltage

Causes	Checking Method	Corrective Actions
The input voltage of the main circuit is lower than the rated allowable voltage.	Check if the input voltage wiring of the main circuit is normal.	Re-confirm the voltage wiring.
No power supply for the main circuit.	Use the voltmeter to see if the voltage of the main circuit is normal.	Check the power switch
Wrong power input (incorrect power system)	Use the voltmeter to see if the power system matches the specification.	Apply to the correct power supply or serial adaptor.

**AL004 : Motor Combination Error**

Causes	Checking Method	Corrective Actions
The encoder is damaged.	The encoder is abnormal.	Change the motor
The encoder is loose.	Check the encoder connector.	Install the motor again.
Motor Combination Error	Connect to the right motor.	Change the motor

**AL005 : Regeneration Error**

Causes	Checking Method	Corrective Actions
The regenerative resistor is unconnected or too low	Check the connection of regenerative resistor.	Reconnect the regenerative resistor or calculate the value of the regenerative resistor.
Parameter P1-53 is not set to zero when the regenerative resistor is not in use.	Check if parameter P1-53 of regenerative resistor is set to zero.	Set parameter P1-53 of regenerative resistor to zero when it is not applying.
Wrong parameter setting	Check the setting value of parameter P1-52 and P1-53.	Correctly reset the setting.

**AL006 : Overload**

Causes	Checking Method	Corrective Actions
Over the rated loading of the drive and continuously excessive using	Set parameter P0-02 to 11 and see if the average torque [%] is over 100% all the time.	Increase the motor capacity or reduce the load.
The setting of the control system parameter is inappropriate.	1. Check if there is any mechanical vibration. 2. Check if the acceleration / deceleration constant are set too fast.	1. Adjust the gain value of the control circuit. 2. Slow down the acceleration / deceleration setting time.
Wrong wiring of the motor and the encoder.	Check the wiring of U, V, W and the encoder.	Correct wiring
The encoder of the motor is defective.	Send the drive back to the distributors or contact with Delta.	

**AL007 : Overspeed**

Causes	Checking Method	Corrective Actions
Unreasonable command	Use the scope to check if the signal of analog voltage is abnormal.	Less steep command used or filter applying to smooth command.
Inappropriate parameter setting	Check if the setting of parameter P2-34 is too small (the condition of over-speed warning).	Correctly set parameter P2-34 (the condition of over-speed warning).

**AL008 : Abnormal Pulse Command**

Causes	Checking Method	Corrective Actions
The pulse command frequency is higher than the rated input frequency.	Use the scope to check if the input frequency is over the rated input frequency.	Correctly set the input pulse frequency.

**AL009 : Excessive Deviation of Position Command**

Causes	Checking Method	Corrective Actions
Parameter P2-35 is set too small	Check the setting value of parameter P2-35 (The warning condition of excessive position deviation)	Increase the setting value of P2-35 (The warning condition of excessive position deviation)
The setting of the gain value is too small.	Check if the setting value is appropriate	Correctly adjust the gain value
The torque limit is too low.	Check the torque limit value	Correctly adjust the torque limit value
Excessive external load	Check the external load	Reduce the external load or evaluate the motor capacity again
Improper setting of E-gear ratio	Make sure if the proportion of P1-44 and P1-45 is appropriate.	Correctly setup E-gear ratio

**AL011 : Encoder Error**

Causes	Checking Method	Corrective Actions
Wrong wiring of the encoder	Check if the wiring follows the suggested wiring of the user manual.	Correct wiring
The encoder is loose	Check the drive connector of CN2 and encoder	Install the encoder again
Bad connection of the encoder	Check if the connection between CN2 of the drive and the encoder of the servo motor is loose	Reconnect the wiring
The encoder is damaged	Check if the motor is damaged	Change the motor

**AL012 : Adjustment Error**

Causes	Checking Method	Corrective Actions
The analog input contact is incorrectly set back to zero	Measure if the voltage of the analog input contact is the same as the ground voltage	Correctly ground the analog input contact
The detection device is damaged	Reset the power supply	If the error still occurs after reset, send the drive back to the distributors or contact with Delta.

**AL013 : Emergency Stop**

Causes	Checking Method	Corrective Actions
Press the emergency stop button	Check if the emergency stop button is enabled.	Activate emergency stop

**AL014 : Reverse Limit Error**

Causes	Checking Method	Corrective Actions
Reverse limit switch is activated.	Check if the limit switch is enabled.	Enable the reverse limit switch
The servo system is unstable.	Check the control parameter and inertia ratio	Re-adjust the parameter or evaluate the motor capacity.

**AL015 : Forward Limit Error**

Causes	Checking Method	Corrective Actions
Forward limit switch is activated.	Check if the limit switch is enabled.	Enable the forward limit switch
The servo system is unstable.	Check the control parameter and inertia ratio	Re-adjust the parameter or evaluate the motor capacity.

**AL016 : IGBT Overheat**

Causes	Checking Method	Corrective Actions
Over the rated loading of the drive and continuously excessive using	Check if it is overloading or the motor current is too high.	Increase the motor capacity or reduce the load.
The drive output is short-circuit	Check the drive output wiring	Correct wiring

**AL017 : Abnormal EEPROM**

Causes	Checking Method	Corrective Actions
It is in error when DSP accesses EEPROM.	Press the SHIFT Key on the panel and it shows EXGAB. X = 1, 2, 3 G = group code of the parameter AB = hexadecimal of the parameter If it shows E320A, it means it is parameter P2-10; If it shows E3610, it means it is parameter P6-16. Please check the parameter.	The fault occurs when applying to the power. It means one of the parameters is over the reasonable range. Please re-power on after adjusting.  The fault occurs in normal operation. It means it is in error when writing the parameter. The alarm can be cleared by DI.ARST.
Abnormal hidden parameter	Press the SHIFT Key on the panel and it shows E100X	The fault occurs in parameter reset. The setting of the drive is wrong. Please set the correct type of the drive.
Data in ROM is damaged.	Press the SHIFT Key on the panel and it shows E0001	The fault occurs when it is servo-on. Usually it is because the data in ROM is damaged or there is no data in ROM. Please send the drive back to the distributors or contact with Delta.



**AL018 : Abnormal Signal Output**

Causes	Checking Method	Corrective Actions
The encoder is in error and cause the abnormal signal output	Check the fault records (P4-00~P4-05). See if the alarm exists with the encoder error (AL011, AL024, AL025, AL026)	Conduct the corrective actions of AL.011, AL.024, AL.025, AL.026
The output pulse exceeds the hardware allowable range.	Check if the following conditions produce: P1-76 < Motor Speed or $\frac{\text{Motor Speed}}{60} \times P1 - 46 \times 4 > 19.8 \times 10^6$	Correctly set parameter P1-76 and P1-46: P1-76 > Motor Speed or $\frac{\text{Motor Speed}}{60} \times P1 - 46 \times 4 < 19.8 \times 10^6$

**AL019 : Serial Communication Error**

Causes	Checking Method	Corrective Actions
Improper setting of the communication parameter	Check the setting value of communication parameter	Correctly set the parameter value
Incorrect communication address	Check the communication address	Correctly set the communication address
Incorrect communication value	Check the accessing value	Correctly set the value

**AL020 : Serial Communication Time Out**

Causes	Checking Method	Corrective Actions
Improper setting of the time-out parameter	Check the parameter setting	Correctly set the value
The drive hasn't received the communication command for a long time.	Check if the communication cable is loose or broken.	Correct wiring

**AL022 : Main circuit power leak phase**

Causes	Checking Method	Corrective Actions
The main circuit power is abnormal	Check if RST power cable is loose or does not connect to the power. This alarm occurs when no power connects to 3-phase for under 1.5 kW (included) servo drive. No power connects to single phase for 2 kW (included or above) servo drive, this alarm occurs.	Make sure it applies to the power. If issue persists, please send the drive back to the distributors or contact with Delta.

**AL023 : Early warning for overload**

Causes	Checking Method	Corrective Actions
Early warning for overload	<ol style="list-style-type: none"> <li>1. Check if it is used in overload condition.</li> <li>2. Check if the value of parameter P1-56 is set to small.</li> </ol>	<ol style="list-style-type: none"> <li>1. Please refer to the corrective actions of AL006.</li> <li>2. Please increase the setting value of parameter P1-56. Or set the value over 100 and deactivate the overload warning function.</li> </ol>

**AL024 : Encoder initial magnetic field error**

Causes	Checking Method	Corrective Actions
The initial magnetic field of the encoder is in error (Signal, U, V, W of the encoder magnetic field is in error.)	<ol style="list-style-type: none"> <li>1. Check if the servo motor is properly grounded.</li> <li>2. Check if the encoder cable separates from the power supply or the high-current circuit to avoid the interference.</li> <li>3. Check if the shielding cables are used in the wiring of the encoder.</li> </ol>	If issue persists, please send the drive back to the distributors or contact with Delta.

**AL025 : The internal of the encoder is in error**

Causes	Checking Method	Corrective Actions
The internal of the encoder is in error. (The internal memory and the internal counter are in error)	<ol style="list-style-type: none"> <li>1. Check if the servo is properly grounded.</li> <li>2. Check if the encoder cable separates from the power supply or the high-current circuit to avoid the interference.</li> <li>3. Check if the shielding cables are used in the wiring of the encoder.</li> </ol>	<ol style="list-style-type: none"> <li>1. Please connect the UVW connector (color green) to the heat sink of the servo drive.</li> <li>2. Please check if the encoder cable separates from the power supply or the high-current circuit.</li> <li>3. Please use shielding mesh.</li> <li>4. If issue persists, please send the drive back to the distributors or contact with Delta.</li> </ol>
When power on, the motor operates because of mechanical inertia or other causes	When power on, please make sure the motor shaft stands still and will not operate.	When power on, please make sure the motor shaft stands still and will not operate.

**AL026 : Unreliable internal data of the encoder**

Causes	Checking Method	Corrective Actions
The encoder is in error. (Errors occur in the internal data for three times continuously)	<ol style="list-style-type: none"> <li>1. Check if the servo is properly grounded.</li> <li>2. Check if the encoder cable separates from the power supply or the high-current circuit to avoid the interference.</li> <li>3. Check if the shielding cables are used in the wiring of the encoder.</li> </ol>	<ol style="list-style-type: none"> <li>1. Please connect the UVW connector (color green) to the heat sink of the servo drive.</li> <li>2. Please check if the encoder cable separates from the power supply or the high-current circuit.</li> <li>3. Please use shielding mesh.</li> <li>4. If issue persists, please send the drive back to the distributors or contact with Delta.</li> </ol>

**AL027 : The internal of the motor is in error**

Causes	Checking Method	Corrective Actions
The internal reset of the encoder is in error.	<ol style="list-style-type: none"> <li>1. Check if the servo is properly grounded.</li> <li>2. Check if the encoder cable separates from the power supply or the high-current circuit to avoid the interference.</li> <li>3. Check if the shielding cables are used in the wiring of the encoder.</li> </ol>	<ol style="list-style-type: none"> <li>1. Please connect the UVW connector (color green) to the heat sink of the servo drive.</li> <li>2. Please check if the encoder cable separates from the power supply or the high-current circuit.</li> <li>3. Please use shielding mesh.</li> <li>4. If the situation is not improving, please send the drive back to the distributors or contact with Delta.</li> </ol>

**AL028 : Encoder voltage error or the internal of the encoder is in error**

Causes	Checking Method	Corrective Actions
Battery voltage is too high	<ol style="list-style-type: none"> <li>1. Check if the charging circuit exists in the servo drive.</li> <li>2. Check if the battery is correctly installed</li> </ol>	According to the procedure of Over voltage to check. When corrective actions are done, AL.028 will be cleared automatically.
The internal encoder is in error.	<ol style="list-style-type: none"> <li>1. Check if it is the absolute type encoder.</li> <li>2. Check if the servo is properly grounded.</li> <li>3. Check if the encoder cable separates from the power supply or the high-current circuit to avoid the interference.</li> <li>4. Check if the shielding cables are used in the wiring of the encoder.</li> </ol>	<ol style="list-style-type: none"> <li>1. If the situation is not improving, please send the drive back to the distributors or contact with Delta.</li> <li>2. Please connect the UVW connector (color green) to the heat sink of the servo drive.</li> <li>3. Please check if the encoder cable separates from the power supply or the high-current circuit.</li> <li>4. Please use shielding mesh. If the situation is not improving, please send the drive back to the distributors or contact with Delta.</li> </ol>

**AL029 : Gray code error**

Causes	Checking Method	Corrective Actions
Absolute position is in error	Re-power on to operate the motor and check if the alarm will occur again.	If the alarm occurs again, please change the encoder.

**AL030 : Motor Crash Error**

Causes	Checking Method	Corrective Actions
Motor Crash Error	<ol style="list-style-type: none"> <li>1. Check if P1-57 is enabled.</li> <li>2. Check if P1-57 is set too small and the time of P1-58 is set too short.</li> </ol>	<ol style="list-style-type: none"> <li>1. If it is enabled by mistake, please set P1-57 to zero.</li> <li>2. According to the actual torque setting, if the value is set too small, the alarm will be triggered by mistake. However, if the value is set too big, it will lose</li> </ol>

		the function of protection.
--	--	-----------------------------

**AL031 : Incorrect wiring of the motor power line U, V, W**

Causes	Checking Method	Corrective Actions
The wiring of U, V, W of the motor is incorrect connected or the connection is breakdown. (Function of connection detection can be enabled or disabled via P2-65 Bit 9. Its default setting is to disable the function.)	Check if U, V, W of the motor is incorrect connected or the connection is breakdown.	Follow the user manual to correctly wire U, V, and W and make sure it is grounded.

**AL034 : Internal communication of the encoder is in error**

Causes	Checking Method	Corrective Actions
Internal communication of the encoder is in error	<ol style="list-style-type: none"> <li>1. Internal communication error of the absolute encoder</li> <li>2. Internal error of other type of encoder</li> </ol>	Conduct the wiring of the battery again and re-power on after that.

**AL035 : Encoder temperature exceeds the protective range**

Causes	Checking Method	Corrective Actions
Encoder temperature exceeds the protective range, above 105°C	Check the setting: Set the value of P0-02 to 120 to display the temperature.	<ol style="list-style-type: none"> <li>1. Improve heat dissipation or reduce the loading of operation. The temperature should be lower than 100°C.</li> <li>2. If the encoder's temperature is higher than the motor's (more than 30 degree). Please send the motor back to the distributors.</li> </ol>

**AL040 : Excessive deviation of full closed-loop position control**

Causes	Checking Method	Corrective Actions
Excessive deviation of full closed-loop position control	<ol style="list-style-type: none"> <li>1. Check if P1-73 is set too small.</li> <li>2. Check if the connector is loose or there is any connection problem of other mechanism.</li> </ol>	<ol style="list-style-type: none"> <li>1. Increase the value of P1-73.</li> <li>2. Check if the connection is well connected.</li> </ol>

**AL041 : Communication of linear scale is breakdown**

Causes	Checking Method	Corrective Actions
The communication of linear scale is breakdown	Check the communication of linear scale.	Check the communication of linear scale again.

**AL042 : Analog input voltage error**

Causes	Checking Method	Corrective Actions
The analog input voltage is higher than the value of P1-83.	Check if analog input voltage is too high.	Check all analog input voltages. Check if there is any problem about the sources of analog speed commands.

**AL044 : Warning of servo drive function overload**

Causes	Checking Method	Corrective Actions
Warning of servo drive function overload	N/A	Set P2-66 Bit4 to 1 can disable the display of this alarm.

**AL045 : Wrong setting of E-gear ratio**

Causes	Checking Method	Corrective Actions
Setting of E-gear ratio is wrong when power on the servo drive	Check if the setting of E-gear ratio is within the range (1/50~25600).	Modify the range of E-gear ratio and repower on the servo drive.

**AL060 : The absolute position is lost**

Causes	Checking Method	Corrective Actions
Battery undervoltage	Check if the voltage of the battery is lower than 2.8V.	After change the battery, conduct homing procedure again. Please refer to the description of absolute coordinate initialization in Chapter 12.
Change the battery when the power is OFF which is controlled by the servo drive	Do no change or remove the battery when the power is OFF which is controlled by the servo drive.	Conduct homing procedure again. Please refer to the description of absolute coordinate initialization in Chapter 12.
After activating the absolute function, the absolute coordinate initialization has not been completed.	<ol style="list-style-type: none"> <li>1. Install the battery.</li> <li>2. Check the wiring between the battery pack and the power cable of the servo drive.</li> <li>3. Check the wiring of the encoder.</li> </ol>	Conduct homing procedure. Please refer to the description of absolute coordinate initialization in Chapter 12.
Bad connection of the battery power circuit	<ol style="list-style-type: none"> <li>1. Check the wiring of the encoder.</li> <li>2. Check the wiring between the battery pack and the power cable of the servo drive.</li> </ol>	Connect or repair the wiring of the battery so as to supply the power to the encoder. Conduct homing procedure again. Please refer to the description of absolute coordinate initialization in Chapter 12.

**AL061 : Encoder under voltage**

Causes	Checking Method	Corrective Actions
Battery under voltage	<ol style="list-style-type: none"> <li>1. Check if the voltage of the battery on the panel is lower than 3.1 V (tentative specification).</li> <li>2. Measure if the voltage of the battery is lower than 3.1 V (tentative specification).</li> </ol>	Do not change the battery when the power is ON which is controlled by the servo drive. After change the battery, AL061 will be cleared automatically.

**AL062 : The multi-turn of absolute encoder overflows**

Causes	Checking Method	Corrective Actions
The operation distance exceeds the range the absolute encoder is able to record	Check if the operation distance exceeds the range, -32768 ~ +32767, the absolute encoder is able to record.	Conduct homing procedure again. Please refer to the description of absolute coordinate initialization in Chapter 12.

**AL067 : Encoder temperature warning**

Causes	Checking Method	Corrective Actions
Encoder temperature exceeds the warning level. (But it is still within the protective range 85 ~100°C.)	Check the setting: Set the value of P0-02 to 120 to display the temperature.	<ol style="list-style-type: none"> <li>1. Improve heat dissipation or reduce the loading of operation. The temperature should be lower than 100°C.</li> <li>2. If the encoder's temperature is higher than the motor's (more than 30 degree). Please send the motor back to the distributors.</li> </ol>

**AL068 : Absolute data transmitted via I/O is in error**

Causes	Checking Method	Corrective Actions
Sequence error	<ol style="list-style-type: none"> <li>1. Switch OFF DI ABSQ should wait until DO ABSR is OFF.</li> <li>2. Switch ON ABSQ should wait until DO ABSR is ON.</li> </ol>	Correct the reading sequence of I/O
Reading time out	Check if the time between switching ON DO ABSR and switching ON ABSQ exceeds 200ms.	After switching ON DO ABSR (the absolute position data is ready), read DO ABSD and switch ON DI ABSQ within 200ms so that to inform the servo drive data reading is completed.

**AL069 : Wrong motor type**

Causes	Checking Method	Corrective Actions
Incremental motor is not allowed to activate the absolute function	<ol style="list-style-type: none"> <li>1. Check if the motor is incremental or absolute encoder.</li> <li>2. Check parameter P2-69.</li> </ol>	If the user desires to use absolute function, please choose absolute motor. If not, please set parameter P2-69 to 0.

**AL06A : The absolute coordinate has not been initialized**

Causes	Checking Method	Corrective Actions
The motor is used for the first time or the battery had run dry but has replaced a new one.	Check if the absolute coordinate has been initialized.	Initialize the absolute coordinate.

**AL070 : Encoder does not complete the command which is issued by servo drive**

Causes	Checking Method	Corrective Actions
Servo drive has not completely written barcode into encoder or the encoder does not complete the command issued by servo drive.	Check if the wiring is correct or there is any loose connection.	Correct the wiring.

**AL083 : Servo Drive Outputs Excessive Current**

Causes	Checking Method	Corrective Actions
UVW cable is short-circuited	Check the configuration of motor power cable and connector cable. See if the metal wire is exposed or AWG is worn and causes short circuit of UVW cable.	Replace by new UVW cable and avoid the metal conductor being exposed so as to eliminate short-circuit.
Wrong motor wiring	<ol style="list-style-type: none"> <li>1. If applying non-standard power cable recommended by Delta, please check if the wiring sequence of UVW cable is correct.</li> <li>2. Check if there is any problem of lack phase when connecting UVW from servo to motor (unconnected or wrong connection)</li> </ol>	Please refer to the description of wiring in Chapter 3 and conduct the wiring again.
Analog signal (GND) from servo drive is interfered	Check if the GND of analog signal is misconnected to other signal.	Please refer to Chapter 3 and conduct the wiring again. GND of analog signal cannot be grounded with other signals.

**AL085 : Regeneration Error**

Causes	Checking Method	Corrective Actions
Choose wrong regenerative resistor or does not connect to external regenerative resistor	Check the connection of regenerative resistor.	Calculate the value of the regenerative resistor again and correctly set the value of P1-52 and P1-53. If issue persists, please send the drive back to the distributors or contact with Delta.
Parameter P1-53 is not set to zero when the regenerative resistor is not in use.	Check if parameter P1-53 of regenerative resistor is set to zero.	Set parameter P1-53 of regenerative resistor to zero when it is not applying.
Wrong parameter setting	Check the setting value of parameter P1-52 and P1-53.	Correctly reset the value of P1-52 and P1-53.

**AL095 : The servo drive does not connect to external regenerative resistor**

Causes	Checking Method	Corrective Actions
The input of regenerative resistor capacity is over 0 and the servo drive does not connect to external regenerative resistor	<ol style="list-style-type: none"> <li>1. Check if it is connected to regenerative resistor.</li> <li>2. Check if the setting value of P1-53 is 0.</li> </ol>	<ol style="list-style-type: none"> <li>1. If wish to apply regenerative brake, please connect to external regenerative resistor. Then, check if the setting of P1-53 is correct.</li> <li>2. If not applying to regenerative brake, please set P1-53 to 0.</li> <li>3. If issue persists after conducting the above two steps, please send the drive back to distributors or contact with Delta.</li> </ol>

**AL099 : DSP firmware upgrade**

Causes	Checking Method	Corrective Actions
Upgrade DSP firmware	Check if the firmware is upgraded.	Firstly set P2-08 to 30. Then set P2-08 to 28, the alarm will be cleared when re-power on.

**AL111 : CANopen SDO receives overflow**

Causes	Checking Method	Corrective Actions
SDO Rx Buffer overflow (receives more than two SDOs within 1ms)	Check if the servo drive receives (sends) more than one SDO within 1ms.	NMT: Reset node or 0x6040.Fault Reset

**AL112 : CANopen PDO receives overflow**

Causes	Checking Method	Corrective Actions
PDO Rx Buffer overflow (receives more than two PDOs of COBID within one millisecond)	Check if the servo drive receives (sends) more than one PDO of COBID within 1ms.	NMT: Reset node or 0x6040.Fault Reset



**AL121 : Index error occurs when accessing CANopen PDO**

Causes	Checking Method	Corrective Actions
The specified Index in the message does not exist.	Check if the Entry Index of PDO Mapping is modified when PDO is receiving or sending	NMT: Reset node or 0x6040.Fault Reset

**AL122 : Sub-Index error occurs when accessing CANopen PDO**

Causes	Checking Method	Corrective Actions
The specified Sub-Index in the message does not exist.	Check if the Entry Sub-index of PDO Mapping is modified when PDO is receiving or sending.	NMT: Reset node or 0x6040.Fault Reset

**AL123 : Data Size error occurs when accessing CANopen PDO**

Causes	Checking Method	Corrective Actions
The data length in the message does not match to the specified object.	Check if the data length of Entry of PDO Mapping is modified when PDO is receiving or sending.	NMT: Reset node or 0x6040.Fault Reset

**AL124 : Data range error occurs when accessing CANopen PDO**

Causes	Checking Method	Corrective Actions
The data value in the message is over the range of the specified object.	Check if the written range is wrong when PDO is receiving or sending.	NMT: Reset node or 0x6040.Fault Reset

**AL125 : CANopen PDO is read-only and write-protected**

Causes	Checking Method	Corrective Actions
The specified object in the message is write-protected.	Check if the specified object is read-only when PDO is receiving or sending.	NMT: Reset node or 0x6040.Fault Reset

**AL126 : CANopen PDO is not allowed in PDO**

Causes	Checking Method	Corrective Actions
The specified object in the message does not support PDO.	Check if the specified object allows PDO Mapping when PDO is receiving or sending.	NMT: Reset node or 0x6040.Fault Reset

**AL127 : CANopen PDO is write-protected when Servo On**

Causes	Checking Method	Corrective Actions
The specified object in the message is write-protected when Servo ON	Check that when PDO is receiving or sending, if the specified object is write-protected when Servo On.	NMT: Reset node or 0x6040.Fault Reset

**AL128 : Error occurs when reading CANopen PDO via EEPROM**

Causes	Checking Method	Corrective Actions
An error occurs when loading the default value via ROM at start-up. All objects of CAN returns to the default value automatically.	When PDO is receiving or sending, check if the error occurs because the specified object reads EEPROM.	NMT: Reset node or 0x6040.Fault Reset

**AL129 : Error occurs when writing CANopen PDO via EEPROM**

Causes	Checking Method	Corrective Actions
An error occurs when saving the current value into ROM.	When PDO is receiving or sending, check if the error occurs because the specified object is wrote into EEPROM	NMT: Reset node or 0x6040.Fault Reset

**AL130 : The accessing address of EEPROM is out of range when using CANopen PDO**

Causes	Checking Method	Corrective Actions
The quantity of the data inside ROM is over the planned space. It is probably because the software has been updated. The data inside ROM is stored by the old version. Thus, it cannot be used.	Check that when PDO is receiving or sending, if the specified object enables EEPROM address exceeds the limit.	NMT: Reset node or 0x6040.Fault Reset

**AL131 : CRC of EEPROM calculation error occurs when using CANopen PDO**

Causes	Checking Method	Corrective Actions
It means the data stored in ROM is damaged. All CANopen objects automatically returns to the default value.	Check if the specified object would cause CRC calculation error in EEPROM when PDO is receiving or sending.	NMT: Reset node or 0x6040.Fault Reset

**AL132 : Enter the incorrect password when using CANopen PDO**

Causes	Checking Method	Corrective Actions
When entering parameters via CAN, parameters are password-protected. Users have to decode the password first.	Check if the specified object enters the wrong password when PDO is receiving or sending.	NMT: Reset node or 0x6040.Fault Reset

**AL170 : CANopen Heartbeat or NodeGuarding error**

Causes	Checking Method	Corrective Actions
CANopen communication breaks	Check if CANopen communication and connection is normal.	NMT:Reset node or 0x6040.Fault Reset

**AL180 : CANopen Heartbeat or NodeGuarding error**

Causes	Checking Method	Corrective Actions
CANopen communication breaks	Check if CANopen communication and connection is normal.	NMT:Reset node or 0x6040.Fault Reset

**AL185 : Abnormal CAN Bus hardware**

Causes	Checking Method	Corrective Actions
Abnormal CAN Bus hardware	<ol style="list-style-type: none"> <li>1. Check if the communication cable of CAN Bus is good.</li> <li>2. Check if the communication quality is good. (It is suggested to use common grounding and shielded cable)</li> </ol>	NMT: Reset node or re-servo on

**AL186 : Bus off**

Causes	Checking Method	Corrective Actions
CAN Bus transfer error	Check if the communication is correctly connected or if there is any interference	Change the communication cable or clear the noise
	The number of slave station is excessive and the communication cycle period is too short.	Lengthen the communication cycle period

**AL201 : An error occurs when loading CANopen data**

Causes	Checking Method	Corrective Actions
An error occurs when loading CANopen data	<ol style="list-style-type: none"> <li>1. If the alarm is cleared when re-servo on, it means the data error occurs instantaneously when accessing in the previous time.</li> <li>2. If the error still exists after re-servo on, it means the data in EEPROM is damaged. It has to enter the correct value again. The method is as the followings: <ol style="list-style-type: none"> <li>a. If the user desires to enter the default value, it can set P2-08 to 30, 28 or CANopen object as 0x1011.</li> <li>b. If the user desires to enter the current value, it can set CANopen object to 0x1010. (Please refer to CANopen description.)</li> </ol> </li> </ol>	DI.ARST, CANopen 0x1011 Restore default parameter

**AL207 : Parameter group of PR#8 is out of the range**

Causes	Checking Method	Corrective Actions
The parameter group of command source exceeds the range	Writing parameter via PR procedure: The parameter group of command source exceeds the	DI.Alm Reset or write 0 into P0-01

	range	
--	-------	--

**AL209 : Parameter number of PR#8 is out of the range**

Causes	Checking Method	Corrective Actions
The parameter number of command source exceeds the range	Writing parameter via PR procedure: The parameter number of command source exceeds the range	DI.Alm Reset or write 0 into P0-01

**AL213 ~ AL217 : An error occurs when writing parameter via PR**

Causes	Checking Method	Corrective Actions
PR commands TYPE 8 Error occurs when writing parameters	<b>AL213</b> : parameter exceeds the range	DI.Alm Reset or P0-01 = 0
	<b>AL215</b> : the parameter is read-only	
	<b>AL217</b> : Servo On or invalid value	Re-adjust PR command and parameters

**AL231 : The setting of monitor item of PR#8 is out of the range**

Causes	Checking Method	Corrective Actions
The monitor item of the command source exceeds the range	Writing parameter via PR procedure: The monitor item number of command source exceeds the range	DI.Alm Reset or write 0 into P0-01

**AL235 : PR command overflows**

Causes	Checking Method	Corrective Actions
PR command error	<p>Incremental type: PR mode continuously operates in one direction and causes feedback register (FB_PUU) overflows. And the coordinate system cannot reflect the correct position. If issuing the absolute positioning command at this time, the error will occur.</p> <p>Absolute type: The error occurs in following situations:</p> <ol style="list-style-type: none"> <li>1. Feedback register (FB_PUU) overflows</li> <li>2. After P1.01.Z is modified, the system neither returns to the original point nor conducts homing procedure.</li> <li>3. It does not conduct homing procedure after the E-gear ratio is modified (P1-44 and P1-45).</li> <li>4. Returning to the original point is</li> </ol>	Conduct homing procedure

	<p>triggered and the homing procedure is not complete.</p> <p>5. AL.060 and AL.062 occur.</p>	
--	---	--

**AL237 : Indexing coordinate is undefined**

Causes	Checking Method	Corrective Actions
When executing indexing function, if the index positioning command is directly executing before defining the start point of index coordinate, the alarm will therefore occur.	Indexing coordinate is undefined and then execute index positioning command.	<ol style="list-style-type: none"> <li>1. Before executing indexing function, please conduct homing first so as to avoid this alarm.</li> <li>2. When the alarm occurs, please use DI:Alm Reset or write 0 into P0-01 to clear the alarm.</li> <li>3. The alarm can be cleared when it is Servo ON.</li> </ol>

**AL283 : Forward Software Limit**

Causes	Checking Method	Corrective Actions
Forward software limit	Forward Software Limit is determined by the position command, not the actual feedback position. It is because the command will arrive first and then the feedback. When the protection function is activated, the actual position might not over the limit. Therefore, setting an appropriate decelerating time could satisfy the demand. Please refer to the description of parameter P5-03.	NMT: Reset node or 0x6040.Fault Reset

**AL285 : Reverse Software Limit**

Causes	Checking Method	Corrective Actions
Reverse software limit	Reverse Software Limit is determined by the position command, not the actual feedback position. It is because the command will arrive first and then the feedback. When the protection function is activated, the actual position might not over the limit. Therefore, setting an appropriate decelerating time could satisfy the demand. Please refer to the description of parameter P5-03.	NMT: Reset node or 0x6040.Fault Reset

**AL289 : Feedback position counter overflows**

Causes	Checking Method	Corrective Actions
Feedback position counter overflows	This alarm will not occur at the moment. If it does, please contact the distributors.	NMT: Reset node or 0x6040.Fault Reset

**AL291 : Servo Off error**

Causes	Checking Method	Corrective Actions
Servo Off error	<ol style="list-style-type: none"> <li>1. Check if the wiring of DI.SERVO ON is correct</li> <li>2. Check if the controller servo on the drive too early.</li> </ol>	NMT: Reset node or 0x6040.Fault Reset

**AL301 : CANopen fails to synchronize**

Causes	Checking Method	Corrective Actions
CANopen fails to synchronize	<ol style="list-style-type: none"> <li>1. Check if the communication quality of the circuit is bad.</li> <li>2. Check if the controller sends SYNC signal successfully.</li> <li>3. Check if the setting of P3-09 is reasonable. (It is better to use the default value)</li> </ol>	NMT: Reset node or 0x6040.Fault Reset

**AL302 : The synchronized signal of CANopen is sent too fast**

Causes	Checking Method	Corrective Actions
The synchronized signal of CANopen is sent too fast	<ol style="list-style-type: none"> <li>1. Check if synchronized cycle 0x1006 is the same as the setting of controller.</li> <li>2. Check if the setting of P3-09 is reasonable. (It is better to use the default value)</li> <li>3. Check if the order of controller is incorrect.</li> </ol>	NMT: Reset node or 0x6040.Fault Reset

**AL303 : The synchronized signal of CANopen is sent too slow**

Causes	Checking Method	Corrective Actions
The synchronized signal of CANopen is sent too slow	<ol style="list-style-type: none"> <li>1. Check if the communication quality of the circuit is bad.</li> <li>2. Check if synchronized cycle 0x1006 is the same as the setting of controller.</li> <li>3. Check if the setting of P3-09 is reasonable. (It is better to use the default value)</li> <li>4. Check if the order of controller is incorrect.</li> </ol>	NMT: Reset node or 0x6040.Fault Reset

**AL304 : CANopen IP command fails**

Causes	Checking Method	Corrective Actions
CANopen IP command fails	The calculating time of IP mode takes too long. Please disable USB monitoring function.	NMT: Reset node or 0x6040.Fault Reset

**AL305 : SYNC Period is in error**

Causes	Checking Method	Corrective Actions
SYNC Period is in error	Examine the content of 0x1006. If it is smaller than or equals to 0, the alarm will occur.	NMT: Reset node or 0x6040. Fault Reset

**AL380 : Position Deviation Alarm**

Causes	Checking Method	Corrective Actions
DO.MC_OK is ON and becomes OFF.	Please refer to the description of parameter P1-48. After DO.MC_OK ON, DO.MC_OK becomes OFF because DO.TPOS turns OFF. The position of the motor might be deviated by the external force after positioning. This alarm can be cleared by P1-48.Y=0.	DI.Alm Reset or P0-01= 0

**AL400 : Index coordinates error**

Causes	Checking Method	Corrective Actions
Setting of P2-52 is wrong	Check if the setting of P2-52 is within the range. If the setting value is too small, it would cause index coordinates error.	Re-adjust the value of P5-52 until it is appropriate.

**AL401 : Receives NMT reset command when Servo On**

Causes	Checking Method	Corrective Actions
Receives NMT reset command when Servo On	Check if the servo drive receives NMT reset command when Servo On	NMT: Reset node or 0x6040. Fault Reset

**AL404 : Value of PR special filter setting is too big**

Causes	Checking Method	Corrective Actions
Inner position error overflows	The setting value of P1-22 causes inner position error overflows	Re-adjust the value of P1-22 until it is appropriate.

**AL555 : System Failure**

Causes	Checking Method	Corrective Actions
DSP processing error	N/A	If AL555 occurs, do not do anything and send the drive back to the distributors or contact with Delta.

## 10.5 Corrective Actions after the Alarm Occurs

<b>AL001</b>	: Over current	Turn DI.ARST on to clear the alarm
<b>AL002</b>	: Over voltage	Turn DI.ARST on to clear the alarm
<b>AL003</b>	: Undervoltage	The alarm can be cleared after the voltage returns to normal.
<b>AL004</b>	: The magnetic field of the motor is abnormal	The alarm can be cleared after re-power on.
<b>AL005</b>	: Regeneration error	Turn DI.ARST on to clear the alarm
<b>AL006</b>	: Overload	Turn DI.ARST on to clear the alarm
<b>AL007</b>	: Excessive speed deviation	Turn DI.ARST on to clear the alarm
<b>AL008</b>	: Abnormal pulse command	Turn DI.ARST on to clear the alarm
<b>AL009</b>	: Excessive deviation of position control	Turn DI.ARST on to clear the alarm
<b>AL011</b>	: Encoder error	The alarm can be cleared after re-power on.
<b>AL012</b>	: Adjustment error	The alarm can be cleared when removing CN1 wiring and execute auto adjustment.
<b>AL013</b>	: Emergency stop	The alarm can be cleared automatically after turning DI.EMGS off
<b>AL014</b>	: Reverse limit error	Turn DI.ARST on or Servo Off to clear the alarm. The alarm also can be cleared when the motor operates backwards.
<b>AL015</b>	: Forward limit error	Turn DI.ARST on or Servo Off to clear the alarm. The alarm also can be cleared when the motor operates backwards.
<b>AL016</b>	: The temperature of IGBT is abnormal	Turn DI.ARST on to clear the alarm
<b>AL017</b>	: Abnormal EEPROM	If the alarm occurs, then parameter reset is a must. And re-servo on again. If it happens during the operation, please turn DI.ARST on to clear the alarm.
<b>AL018</b>	: Abnormal signal output	Turn DI.ARST on to clear the alarm
<b>AL019</b>	: Serial communication error	Turn DI.ARST on to clear the alarm
<b>AL020</b>	: Serial communication timeout	Turn DI.ARST on to clear the alarm
<b>AL022</b>	: Main circuit power leak phase	Turn DI.ARST on to clear the alarm



<b>AL023</b>	: Early warning for overload	Turn DI.ARST on to clear the alarm
<b>AL024</b>	: Encoder initial magnetic field error	The alarm can be cleared after re-power on.
<b>AL025</b>	: The internal of the encoder is in error	The alarm can be cleared after re-power on.
<b>AL026</b>	: The encoder is in error	The alarm can be cleared after re-power on.
<b>AL027</b>	: Encoder reset error	The alarm can be cleared after re-power on.
<b>AL028</b>	: The encoder is over voltage or the internal of the encoder is in error	The alarm can be cleared after re-power on.
<b>AL029</b>	: Gray code error	The alarm can be cleared after re-power on.
<b>AL030</b>	: Motor crash error	Turn DI.ARST on to clear the alarm
<b>AL031</b>	: Incorrect wiring of the motor power line U, V, W, GND	The alarm can be cleared after re-power on.
<b>AL034</b>	: Internal communication of the encoder is in error	The alarm can be cleared after re-power on.
<b>AL035</b>	: Encoder temperature exceeds the protective range	The temperature sensor of motor shall below 100°C. And the alarm can be cleared after re-power on.
<b>AL040</b>	: Excessive deviation of full closed-loop position control	Turn DI.ARST on to clear the alarm.
<b>AL041</b>	: The communication of linear scale is breakdown	Turn DI.ARST on to clear the alarm.
<b>AL042</b>	: Analog input voltage error	Turn DI.ARST on to clear the alarm.
<b>AL044</b>	: Warning of servo drive function overload	Set P2-66 Bit4 to 1 and then re-power on the servo drive.
<b>AL045</b>	: Wrong setting of E-gear ratio	The alarm can be cleared after correctly setting up the parameter.
<b>AL060</b>	: The absolute position is lost	The alarm can be cleared after re-power on.
<b>AL061</b>	: Encoder under voltage	Change the battery and AL.061 will be cleared automatically.
<b>AL062</b>	: The multi-turn if absolute encoder overflows	The alarm can be cleared after re-power on.
<b>AL067</b>	: Encoder temperature warning	Turn DI.ARST on to clear the alarm.
<b>AL068</b>	: Absolute data transmitted via I/O is in error	The alarm can be cleared after re-power on.
<b>AL069</b>	: Wrong motor type	Set P2-69 to 0 and then re-power on the servo drive.

<b>AL06A</b>	: The absolute coordinate has not been initialized	The alarm can be cleared after initializing the absolute coordinate.
<b>AL070</b>	: Encoder does not complete the command which is issued by servo drive	The alarm can be cleared after re-power on.
<b>AL083</b>	: Servo drive outputs excessive current	Turn DI.ARST on to clear the alarm.
<b>AL085</b>	: The absolute coordinate has not been initialized	Turn DI.ARST on to clear the alarm.
<b>AL095</b>	: The servo drive does not connect to external regenerative resistor	Turn DI.ARST on to clear the alarm.
<b>AL099</b>	: DSP firmware upgrade	Firstly set P2-08 to 30. Then set it to 28. And the alarm will be cleared after re-power on.
<b>AL111</b>	: CANopen SDO receives buffer overflow	NMT: Reset node or 0x6040.Fault Reset
<b>AL112</b>	: CANopen PDO receives buffer overflow	NMT: Reset node or 0x6040.Fault Reset
<b>AL121</b>	: Index error occurs when accessing CANopen PDO	NMT: Reset node or 0x6040.Fault Reset
<b>AL122</b>	: Sub-Index error occurs when accessing CANopen PDO	NMT: Reset node or 0x6040.Fault Reset
<b>AL123</b>	: Data Size error occurs when accessing CANopen PDO	NMT: Reset node or 0x6040.Fault Reset
<b>AL124</b>	: Data range error occurs when accessing CANopen PDO	NMT: Reset node or 0x6040.Fault Reset
<b>AL125</b>	: CANopen PDO is read-only and write-protected.	NMT: Reset node or 0x6040.Fault Reset
<b>AL126</b>	: CANopen PDO is not allowed in PDO	NMT: Reset node or 0x6040.Fault Reset
<b>AL127</b>	: CANopen PDO is write-protected when Servo On	NMT: Reset node or 0x6040.Fault Reset
<b>AL128</b>	: Error occurs when reading CANopen PDO via EEPROM	NMT: Reset node or 0x6040.Fault Reset
<b>AL129</b>	: Error occurs when writing CANopen PDO via EEPROM	NMT: Reset node or 0x6040.Fault Reset
<b>AL130</b>	: The accessing address of EEPROM is out of range when using CANopen PDO	NMT: Reset node or 0x6040.Fault Reset
<b>AL131</b>	: CRC of EEPROM calculation error occurs when using CANopen PDO	NMT: Reset node or 0x6040.Fault Reset

<b>AL132</b>	: Enter the incorrect password when using CANopen PDO	NMT: Reset node or 0x6040.Fault Reset
<b>AL170</b>	: Heartbeat or NodeGuarding error	NMT: Reset node or 0x6040.Fault Reset
<b>AL180</b>	: Heartbeat or NodeGuarding error	NMT: Reset node or 0x6040.Fault Reset
<b>AL185</b>	: Abnormal CAN Bus hardware	NMT: Reset node or re-servo on
<b>AL186</b>	: CAN bus off	NMT: Reset node or 0x6040.Fault Reset
<b>AL201</b>	: An error occurs when loading CANopen data	Turn DI.ARST on to clear the alarm. CANopen 0x1011 Restore default parameter
<b>AL207</b>	: Parameter group of PR#8 is out of range	1. Turn DI.ARST on to clear the alarm. 2. Set P0-01 to 0.
<b>AL209</b>	: Parameter number of PR#8 is out of range	1. Turn DI.ARST on to clear the alarm. 2. Set P0-01 to 0.
<b>AL213</b>	: An error occurs when writing parameter via PR : exceeds the range	DI.Alm Reset or P0-01 = 0
<b>AL215</b>	: An error occurs when writing parameter via PR : read-only	DI.Alm Reset or P0-01 = 0
<b>AL217</b>	: An error occurs when writing parameter via PR : parameter locked	Re-adjust PR command and parameter
<b>AL231</b>	: The setting of monitor item of PR#8 is out of range	1. Turn DI.ARST on to clear the alarm. 2. Set P0-01 to 0.
<b>AL235</b>	: PR command overflows	NMT: Reset node or 0x6040.Fault Reset
<b>AL237</b>	: Indexing coordinate is undefined	1. Turn DI.ARST on to clear the alarm. 2. Set P0-01 to 0.
<b>AL283</b>	: Forward Software Limit	NMT: Reset node or 0x6040.Fault Reset
<b>AL285</b>	: Reverse Software Limit	NMT: Reset node or 0x6040.Fault Reset
<b>AL289</b>	: Feedback position counter overflows	NMT: Reset node or 0x6040.Fault Reset
<b>AL291</b>	: Servo Off error	NMT: Reset node or 0x6040.Fault Reset

<b>AL301</b>	: CANopen fails to synchronize	NMT: Reset node or 0x6040.Fault Reset
<b>AL302</b>	: The synchronized signal of CANopen is sent too fast	NMT: Reset node or 0x6040.Fault Reset
<b>AL303</b>	: The synchronized signal of CANopen is sent too slow	NMT: Reset node or 0x6040.Fault Reset
<b>AL304</b>	: CANopen IP command is failed	NMT: Reset node or 0x6040.Fault Reset
<b>AL305</b>	: SYNC Period is in error	NMT: Reset node or 0x6040.Fault Reset
<b>AL380</b>	: Position Deviation Alarm	DI.Alm Reset or P0-01 = 0
<b>AL400</b>	: Index coordinates error	Turn DI.ARST on to clear the alarm.
<b>AL401</b>	: NMT Reset command is received when Servo On	Turn DI.ARST on to clear the alarm.
<b>AL404</b>	: Value of PR special filter setting is too big	Turn DI.ARST on to clear the alarm.
<b>AL555</b>	: System Failure	N/A

(This page is intentionally left blank.)

# Chapter 11 Specifications

## 11.1 Specifications of Servo Drives

### 11.1.1 ASDA-A2 220 V Series

ASDA-A2 Series		100 W	200 W	400 W	750 W	1 kW	1.5 kW	2 kW	3k W	4.5 kW	5.5 kW	7.5 kW	11 kW	15 kW	
		01	02	04	07	10	15	20	30	45	55	75	1B	1F	
Power	Phase / Voltage	Single-phase / Three-phase 220 VAC						Three-phase 220 VAC							
	Permissible Voltage	Single-phase / Three-phase 200 ~ 230 VAC, -15% ~ 10%						Three-phase 200 ~ 230 VAC, -15% ~ 10%							
	Input Current (3PH) Unit: Arms	0.39	1.11	1.86	3.66	4.68	5.9	8.76	9.83	17.5	19.4	26.3	48	63	
	Input Current (1PH) Unit: Arms	0.69	1.92	3.22	6.78	8.88	10.3	-	-	-	-	-	-	-	
	Continuous Output Current Unit: Arms	0.9	1.55	2.6	5.1	7.3	8.3	13.4	19.4	32.5	40	47.5	54.4	70	
Cooling method		Natural cooling				Fan Cooling									
Encoder Resolution (Servo Drive Resolution)		Incremental type: 20-bit; Absolute type: 17-bit													
Main Circuit Control		SVPWM (Space Vector Pulse Width Modulation) Control													
Control Mode		Auto / Manual													
Regenerative Resistor		None	Built-in						External						
Position Control Mode	Max. Input Pulse Frequency	Line driver: 500 Kpps / 4 Mpps; Open collector: 200 Kpps													
	Pulse Type	Pulse + Direction, A phase + B phase, CCW pulse + CW pulse													
	Command Source	External pulse (DMCNET mode is not included) / Register													
	Smoothing Strategy	Low-pass and P-curve filter													
	E-gear ratio	E-gear ratio N/M multiple ( $1/50 < N/M < 25600$ ) N: 1 ~ 32767, M: 1:32767													
	Torque Limit	Parameter settings													
	Feed Forward Compensation	Parameters settings													
Speed Control Mode	Analog Command Input (DMCNET mode is not included)	Voltage Range	0 ~ ±10 V <sub>DC</sub>												
		Input Resistance	10 KΩ												
		Time Constant	2.2 us												
	Speed Control Range	1 : 5000						1 : 3000			1 : 2000				
	Command Source	External analog command (DMCNET mode is not included) / Register													
	Smoothing Strategy	Low-pass and S-curve filter													
	Torque Limit	Via parameter settings or analog input													
Bandwidth	Maximum 1 kHz														

Speed Accuracy <sup>*2</sup>		0.01% or less at 0 to 100% load fluctuation
		0.01% or less at $\pm 10\%$ power fluctuation
		0.01% or less at 0°C to 50°C ambient temperature fluctuation
Torque Control Mode	Analog Command Input	Voltage Range 0 ~ $\pm 10$ V <sub>DC</sub>
		Input Resistance 10 K $\Omega$
		Time Constant 2.2 $\mu$ s
	Command Source	External analog command (DMCNET mode is not included) / Register
	Smoothing Strategy	Low-pass filter
	Speed Limit	Via parameter settings or analog input (DMCNET mode is not included)
	Analog Monitor Output	Monitor signal can set by parameters (Output voltage range: $\pm 8$ V)
Digital Input/Output	Input	Servo on, Fault reset, Gain switch, Pulse clear, Zero clamp, Command input reverse control, Internal position command trigger, Torque limit, Speed limit, Internal position command selection, Motor stop, Speed command selection, Speed / position mode switching, Speed / torque mode switching, Torque / position mode switching, PT / PR command switching, Emergency stop, Positive / negative limit, Original point, Forward / reverse operation torque limit, Homing activated, E-CAM engage, Forward / reverse JOG input, Event trigger, E-gear N selection, Pulse input prohibition <small>*DMCNET mode is not included for the DI mentioned above. When applying DMCNET mode, it is suggested to use communication for DI input. Its DI only supports emergency stop, forward/reverse limit and homing.</small>
	Output	A, B, Z Line Driver output Servo on, Servo ready, Zero speed, Target speed reached, Target position reached, torque limiting, Servo alarm, Brake control, Homing completed, Early warning for overload, Servo warning, Position command overflows, Software negative limit (reverse direction), Software positive limit (forward direction), Internal position command completed, Capture procedure completed, Servo procedure completed, Master position area of E-CAM
Protective Function	Over current, Overvoltage, Under voltage, Overheat, Regeneration error, Overload, Excessive speed deviation, Excessive position deviation, Encoder error, Adjustment error, Emergency stop, Negative / positive limit error, Excessive deviation of full-closed loop control, Serial communication error, Rst leak phase, Serial communication timeout, Short-circuit protection of terminal U, V, W and CN1, CN2, CN3	
Communication Interface	RS-232 / RS-485 / CANopen / USB / DMCNET	
Environment	Installation Site	Indoors (avoid the direct sunlight), no corrosive fog (avoid fume, flammable gas and dust)
	Altitude	Altitude 1000 m or lower above sea level
	Atmospheric pressure	86 kPa to 106 kPa
	Operating Temperature	0°C ~ 55°C (If operating temperature is above 45°C, forced cooling will be required)
	Storage Temperature	-20°C to 65°C
	Humidity	Under 0 to 90% (non-condensing)
	Vibrating	9.80665m/s <sup>2</sup> (1 G) less than 20 Hz, 5.88m/s <sup>2</sup> (0.6 G) 20 to 50 Hz
	IP Rating	IP20
	Power System	TN System <sup>*3</sup>
	Approvals	IEC/EN 61800-5-1, UL 508C, C-tick   



## Note:

- \*1 When it is in rated load, the speed ratio is: the minimum speed (smooth operation) /rated speed.
- \*2 When the command is the rated speed, the velocity correction ratio is: (rotational speed with no load – rotational speed with full load) / rated speed.
- \*3 TN system: The neutral point of the power system connects to the ground directly. The exposed metal components connect to the ground via the protective earth conductor.
- 4 Please refer to section 11.4 for overload features.



## 11.1.2 ASDA-A2 400 V Series

ASDA-A2 Series		750 W	1 kW	1.5 kW	2 kW	3 kW	4.5 kW	5.5 kW	7.5 kW
		07	10	15	20	30	45	55	75
Power	Input Voltage	24 VDC, $\pm 10\%$							
	Input Current	0.89 A			1.18 A			1.66 A	
	Input Power	21.4 W			28.2 W			39.85 W	
Main Circuit Power		Three-phase, 380 ~ 480 VAC, $\pm 10\%$							
Input Current (3PH) Unit: Arms		2.22	3.02	4.24	5.65	8.01	11.9	14.1	17.27
Continuous Output Current Unit: Arms		3.07	3.52	5.02	6.66	11.9	20	22.37	30
Cooling method		Fan Cooling							
Encoder Resolution (Servo Drive Resolution)		Incremental type: 20-bit; Absolute type: 17-bit							
Main Circuit Control		SVPWM (Space Vector Pulse Width Modulation) Control							
Control Modes		Auto / Manual							
Regenerative Resistor		Built-in			External				
Position Control Mode	Max. Input Pulse Frequency (DMCNET is not included)	Line driver: 500 Kpps / 4 Mpps; Open collector: 200 Kpps							
	Pulse Type (DMCNET is not included)	Pulse + Direction, A phase + B phase, CCW pulse + CW pulse							
	Command Source	External pulse train (DMCNET is not included) / Internal parameters							
	Smoothing Strategy	Low-pass and P-curve filter							
	E-gear ratio	E-gear ratio: N/M multiple ( $1/50 < N/M < 25600$ ) N: 1 ~ 32767 / M: 1:32767							
	Torque Limit	Parameter settings							
	Feed Forward Compensation	Parameters settings							
Speed Control Mode	Analog Command Input	Voltage Range	0 ~ $\pm 10$ V <sub>DC</sub>						
		Input Resistance	10 K $\Omega$						
		Time Constant	2.2 $\mu$ s						
	Speed Control Range <sup>*1</sup>	1 : 5000					1 : 3000		
	Command Source	External analog command (DMCNET is not included) / Register							
	Smoothing Strategy	Low-pass and S-curve filter							
	Torque Limit	Via parameter settings or analog input							
	Bandwidth	Maximum 1 kHz							
Speed Accuracy <sup>*2</sup>	0.01% or less at 0 to 100% load fluctuation								
	0.01% or less at $\pm 10\%$ power fluctuation								
	0.01% or less at 0°C to 50°C ambient temperature fluctuation								
Analog Command Input	Voltage Range	0 ~ $\pm 10$ V <sub>DC</sub>							

	(DMCNET is not included)	Input Resistance	10 K $\Omega$
		Time Constant	2.2 us
	Command Source		External analog command (DMCNET is not included) / Register
	Smoothing Strategy		Low-pass filter
	Speed Limit		Via parameter settings or analog input (DMCNET is not included)
Analog Monitor Output			Monitor signal can set by parameters (Output voltage range: $\pm 8$ V)
Digital Input/Output	Input		Servo on, Fault reset, Gain switching, Pulse clear, Zero speed CLAMP, Command input reverse control, Command triggered, Torque limit., Speed limit, Position command selection, Motor stop, Speed command selection, Position / Speed mode switching, Speed / Torque mode switching, Torque / Position mode switching, PT / PR command switching, Emergency stop, Forward / Reverse inhibit limit, Original point for homing, Forward / Reverse operation torque limit, Homing activated, E-Cam engage, Forward / Reverse JOG input, Event trigger PR command, Electronic gear ratio (Numerator) selection and Pulse inhibit input *DMCNET mode is not included for the DI mentioned above. When applying DMCNET mode, it is suggested to use communication for DI input. Its DI only supports emergency stop, forward/reverse limit and homing.
	Output		A, B, Z Line Driver output Servo on, Servo ready, Zero speed, Target speed reached, Target position reached, torque limiting, Servo alarm, Brake control, Homing completed, Early warning for overload, Servo warning, Position command overflows, Software negative limit (reverse direction), Software positive limit (forward direction), Internal position command completed, Capture procedure completed, Servo procedure completed, Master position area of E-CAM
Protective Function			Over current, Overvoltage, Under voltage, Overheat, Regeneration error, Overload, Excessive speed deviation, Excessive position deviation, Encoder error, Adjustment error, Emergency stop, Negative / positive limit error, Excessive deviation of full-closed loop control, Serial communication error, Rst leak phase, Serial communication timeout, Short-circuit protection of terminal U, V, W and CN1, CN2, CN3
Communication Interface			RS-232 / RS-485 / CANopen / USB
Environment	Installation Site		Indoor (avoid the direct sunlight), no corrosive fog (avoid fume, flammable gas and dust)
	Altitude		Altitude 1000m or lower above sea level
	Atmospheric pressure		86 kPa to 106 kPa
	Operating Temperature ( $^{\circ}$ C)		0 $^{\circ}$ C ~ 55 $^{\circ}$ C (If operating temperature is above 45 $^{\circ}$ C, forced air circulation will be required)
	Storage Temperature ( $^{\circ}$ C)		-20 $^{\circ}$ C to 65 $^{\circ}$ C
	Humidity		0 to 90% (non-condensing)
	Vibrating		9.80665m/s <sup>2</sup> (1 G) less than 20 Hz, 5.88m/s <sup>2</sup> (0.6 G) 20 to 50 Hz
	IP Rating		IP20
	Power System		TN System <sup>*3</sup>
	Approvals		IEC/EN 61800-5-1, UL 508C, C-tick   

## Note:

- \*1 When it is in rated load, the speed ratio is: the minimum speed (smooth operation) /rated speed.
- \*2 When the command is the rated speed, the velocity correction ratio is: (rotational speed with no load – rotational speed with full load) / rated speed.
- \*3 TN system: The neutral point of the power system connects to the ground directly. The exposed metal components connect to the ground via the protective earth conductor.
- 4 Please refer to section 11.6 for overload features.

## 11.2 Specifications of Servo Motors (ECMA Series)

### 11.2.1 ECMA 220 V Series

#### Low Inertia Series

ECMA Series	C104	C $\Delta$ 04	C $\Delta$ 06		C $\Delta$ 08		C $\Delta$ 09	
	0F	01	02	04□S	04	07	07	10
Rated power (kW)	0.05	0.1	0.2	0.4	0.4	0.75	0.75	1.0
Rated torque (N-m) *1	0.159	0.32	0.64	1.27	1.27	2.39	2.39	3.18
Max. torque (N-m)	0.477	0.96	1.92	3.82	3.82	7.16	7.14	8.78
Rated speed (r/min)	3000						3000	
Max. speed (r/min)	5000						3000	
Rated current (A)	0.69	0.90	1.55	2.60	2.60	5.10	3.66	4.25
Max. instantaneous current (A)	2.05	2.70	4.65	7.80	7.80	15.3	11.0	12.37
Power rating (kW/s)	12.27	27.7	22.4	57.6	24.0	50.4	29.6	38.6
Rotor inertia ( $\times 10^{-4}$ kg.m <sup>2</sup> )	0.0206	0.037	0.177	0.277	0.68	1.13	1.93	2.62
Mechanical constant (ms)	1.2	0.75	0.80	0.53	0.74	0.63	1.72	1.20
Torque constant-KT (N-m/A)	0.23	0.36	0.41	0.49	0.49	0.47	0.65	0.75
Voltage constant-KE (mV/(r/min))	9.8	13.6	16.0	17.4	18.5	17.2	24.2	27.5
Armature resistance (Ohm)	12.7	9.30	2.79	1.55	0.93	0.42	1.34	0.897
Armature inductance (mH)	26.0	24.0	12.07	6.71	7.39	3.53	7.55	5.7
Electric constant (ms)	2.05	2.58	4.30	4.30	7.96	8.36	5.66	6.35
Insulation class	Class A (UL), Class B (CE)							
Insulation resistance	> 100 M $\Omega$ , DC 500 V							
Insulation strength	1.8k Vac, 1 sec							
Weight (kg) (without brake)	0.42	0.5	1.2	1.6	2.1	3.0	2.9	3.8
Weight (kg) (with brake)	--	0.8	1.5	2.0	2.9	3.8	3.69	5.5
Radial max. loading (N)	78.4	78.4	196	196	245	245	245	245
Axial max. loading (N)	39.2	39.2	68	68	98	98	98	98
Power rating (kW/s) (with brake)	--	25.6	21.3	53.8	22.1	48.4	29.3	37.9
Rotor inertia ( $\times 10^{-4}$ kg.m <sup>2</sup> ) (with brake)	--	0.04	0.19	0.30	0.73	1.18	1.95	2.67
Mechanical constant (ms) (with brake)	--	0.81	0.85	0.57	0.78	0.65	1.74	1.22
Brake holding torque [Nt-m (min)] *2	--	0.3	1.3	1.3	2.5	2.5	2.5	2.5

ECMA Series	C104	CΔ 04	CΔ 06		CΔ 08		CΔ 09	
	0F	01	02	04□S	04	07	07	10
Brake power consumption (at 20°C) [W]	--	7.3	6.5	6.5	8.2	8.2	8.2	8.2
Brake release time [ms (Max)]	--	5	10	10	10	10	10	10
Brake pull-in time [ms (Max)]	--	25	70	70	70	70	70	70
Vibration grade (μm)	15							
Operating temperature (°C)	0°C to 40°C							
Storage temperature (°C)	-10°C to 80°C							
Operating humidity	20% to 90% RH (non-condensing)							
Storage humidity	20% to 90% RH (non-condensing)							
Vibration capacity	2.5 G							
IP Rating	IP65 (when waterproof connectors are used, or when an oil seal is used to be fitted to the rotating shaft (an oil seal model is used))							
Approvals								

## Note:

- \*1 The rated torque is the continuous permissible torque between 0~40°C operating temperature which is suitable for the following heat sink dimension.  
 ECMA-\_\_04 / 06 / 08 : 250 mm x 250 mm x 6 mm  
 ECMA-\_\_10 : 300 mm x 300 mm x 12 mm  
 ECMA-\_\_13 : 400 mm x 400 mm x 20 mm  
 ECMA-\_\_18 : 550 mm x 550 mm x 30 mm  
 ECMA-\_\_22 : 650 mm x 650 mm x 35mm  
 Material: Aluminum – F40, F60, F80, F100, F130, F180, F220
- \*2 The built-in brake of the servo motor is for remaining the item in stop status. Do not use it to decelerate or as the dynamic brake.

ECMA Series	CΔ10		CΔ13
	10	20	30
Rated power (kW)	1.0	2.0	3.0
Rated torque (N-m) <sup>*1</sup>	3.18	6.37	9.55
Max. torque (N-m)	9.54	19.11	28.65
Rated speed (r/min)	3000		3000
Max. speed (r/min)	5000		4500
Rated current (A)	7.30	12.05	17.2
Max. instantaneous current (A)	21.9	36.15	47.5
Power rating (kW/s)	38.1	90.6	71.8
Rotor inertia ( $\times 10^{-4}$ kg.m <sup>2</sup> )	2.65	4.45	12.7
Mechanical constant (ms)	0.74	0.61	1.11
Torque constant-KT (N-m/A)	0.44	0.53	0.557
Voltage constant-KE (mV/(r/min))	16.8	19.2	20.98
Armature resistance (Ohm)	0.20	0.13	0.0976
Armature inductance (mH)	1.81	1.50	1.21
Electric constant (ms)	9.30	11.4	12.4
Insulation class	Class A (UL), Class B (CE)		
Insulation resistance	>100 MΩ, DC 500 V		
Insulation strength	1.8k Vac, 1 sec		
Weight (kg) (without brake)	4.3	6.2	7.8
Weight (kg) (with brake)	4.7	7.2	9.2
Radial max. loading (N)	490	490	490
Axial max. loading (N)	98	98	98
Power rating (kW/s) (with brake)	30.4	82.0	65.1
Rotor inertia ( $\times 10^{-4}$ kg.m <sup>2</sup> ) (with brake)	3.33	4.95	14.0
Mechanical constant (ms) (with brake)	0.93	0.66	1.22
Brake holding torque [Nt-m (min)] <sup>*2</sup>	8.0	8.0	10.0
Brake power consumption (at 20°C) [W]	18.7	18.7	19.0
Brake release time [ms (Max)]	10	10	10
Brake pull-in time [ms (Max)]	70	70	70
Vibration grade (μm)	15		

ECMA Series	CΔ10		CΔ13
	10	20	30
Operating temperature (°C)	0°C to 40°C		
Storage temperature (°C)	-10°C to 80°C		
Operating humidity	20% to 90% RH (non-condensing)		
Storage humidity	20% to 90% RH (non-condensing)		
Vibration capacity	2.5 G		
IP Rating	IP65 (use the waterproof connector and shaft seal installation (or oil seal model))		
Approvals			

## Note:

- \*1 The rated torque is the continuous permissible torque between 0~40°C operating temperature which is suitable for the following heat sink dimension.  
 ECMA-\_\_04 / 06 / 08 : 250 mm x 250 mm x 6 mm  
 ECMA-\_\_10 : 300 mm x 300 mm x 12 mm  
 ECMA-\_\_13 : 400 mm x 400 mm x 20 mm  
 ECMA-\_\_18 : 550 mm x 550 mm x 30 mm  
 ECMA-\_\_22 : 650 mm x 650 mm x 35 mm  
 Material: Aluminum – F40, F60, F80, F100, F130, F180, F220
- \*2 The built-in brake of the servo motor is for remaining the item in stop status. Do not use it to decelerate or as the dynamic brake.

## Medium / High Inertia Series

ECMA Series	EΔ 13				EΔ 18			GΔ 13		
	05	10	15	20	20	30	35	03	06	09
Rated power (kW)	0.5	1.0	1.5	2.0	2.0	3.0	3.5	0.3	0.6	0.9
Rated torque (N-m) <sup>*1</sup>	2.39	4.77	7.16	9.55	9.55	14.32	16.71	2.86	5.73	8.59
Max. torque (N-m)	7.16	14.3	21.48	28.65	28.65	42.97	50.13	8.59	17.19	21.48
Rated speed (r/min)	2000							1000		
Max. speed (r/min)	3000							2000		
Rated current (A)	2.9	5.6	8.3	11.01	11.22	16.1	19.2	2.5	4.8	7.5
Max. instantaneous current (A)	8.7	16.8	24.9	33.03	33.66	48.3	57.6	7.5	14.4	22.5
Power rating (kW/s)	7.0	27.1	45.9	62.5	26.3	37.3	50.8	10.0	39.0	66.0
Rotor inertia (× 10 <sup>-4</sup> kg.m <sup>2</sup> )	8.17	8.41	11.18	14.59	34.68	54.95	54.95	8.17	8.41	11.18
Mechanical constant (ms)	1.91	1.51	1.10	0.96	1.62	1.06	1.08	1.84	1.40	1.06
Torque constant-KT (N-m/A)	0.83	0.85	0.87	0.87	0.85	0.89	0.87	1.15	1.19	1.15
Voltage constant-KE (mV/(r/min))	30.9	31.9	31.8	31.8	31.4	32.0	32.0	42.5	43.8	41.6
Armature resistance (Ohm)	0.57	0.47	0.26	0.174	0.119	0.052	0.052	1.06	0.82	0.43
Armature inductance (mH)	7.39	5.99	4.01	2.76	2.84	1.38	1.38	14.29	11.12	6.97
Electric constant (ms)	12.96	12.88	15.31	15.86	23.87	26.39	26.39	13.50	13.50	16.06
Insulation class	Class A (UL), Class B (CE)									
Insulation resistance	>100 MΩ, DC 500 V									
Insulation strength	1.8k Vac, 1 sec									
Weight (kg) (without brake)	6.8	7.0	7.5	7.8	13.5	18.5	18.5	6.8	7.0	7.5
Weight (kg) (with brake)	8.2	8.4	8.9	9.2	17.5	22.5	22.5	8.2	8.4	8.9
Radial max. loading (N)	490	490	490	490	1176	1470	490	490	490	490
Axial max. loading (N)	98	98	98	98	490	490	98	98	98	98
Power rating (kW/s) (with brake)	6.4	24.9	43.1	57.4	24.1	35.9	48.9	9.2	35.9	62.1
Rotor inertia (× 10 <sup>-4</sup> kg.m <sup>2</sup> ) (with brake)	8.94	9.14	11.90	15.88	37.86	57.06	57.06	8.94	9.14	11.9
Mechanical constant (ms) (with brake)	2.07	1.64	1.19	1.05	1.77	1.10	1.12	2.0	1.51	1.13
Brake holding torque [Nt-m (min)] <sup>*2</sup>	10.0	10.0	10.0	10.0	25.0	25.0	25.0	10.0	10.0	10.0
Brake power consumption (at 20°C) [W]	19.0	19.0	19.0	19.0	20.4	20.4	20.4	19.0	19.0	19.0



ECMA Series	EΔ 13				EΔ 18			GΔ 13		
	05	10	15	20	20	30	35	03	06	09
Brake release time [ms (Max)]	10	10	10	10	10	10	10	10	10	10
Brake pull-in time [ms (Max)]	70	70	70	70	70	70	70	70	70	70
Vibration grade (μm)	15									
Operating temperature (°C)	0°C to 40°C									
Storage temperature (°C)	-10°C to 80°C									
Operating humidity	20% to 90% RH (non-condensing)									
Storage humidity	20% to 90% RH (non-condensing)									
Vibration capacity	2.5 G									
IP Rating	IP65 (use the waterproof connector and shaft seal installation (or oil seal) model)									
Approvals										

## Note:

- \*1 The rated torque is the continuous permissible torque between 0~40°C operating temperature which is suitable for the following heat sink dimension.  
 ECMA-\_\_04 / 06 / 08 : 250 mm x 250 mm x 6 mm  
 ECMA-\_\_10 : 300 mm x 300 mm x 12 mm  
 ECMA-\_\_13 : 400 mm x 400 mm x 20 mm  
 ECMA-\_\_18 : 550 mm x 550 mm x 30 mm  
 ECMA-\_\_22 : 650 mm x 650 mm x 35 mm  
 Material: Aluminum – F40, F60, F80, F100, F130, F180, F220
- \*2 The built-in brake of the servo motor is for remaining the item in stop status. Do not use it to decelerate or as the dynamic brake.

## Medium-High / High Inertia Series

ECMA Series	FΔ 13				FΔ 18				F122	
	05	08	13	18	30	45	55	75	1B	1F
Rated power (kW)	0.5	0.85	1.3	1.8	3.0	4.5	5.5	7.5	11	15
Rated torque (N-m) <sup>*1</sup>	3.18	5.41	8.34	11.48	19.10	28.65	35.01	47.74	70	95.4
Max. torque (N-m)	8.92	13.8	23.3	28.7	57.29	71.62	87.53	119.36	175	224.0
Rated speed (r/min)	1500									
Max. speed (r/min)	3000								2000	
Rated current (A)	3.9	7.1	12.6	13.0	19.4	32.5	40.0	47.5	51.8	67.0
Max. instantaneous current (A)	12.1	19.4	38.6	36.0	58.2	81.3	100.0	118.8	129.5	162.0
Power rating (kW/s)	9.8	21.52	34.78	52.93	66.4	105.5	122.9	159.7	144.9	201.8
Rotor inertia ( $\times 10^{-4}$ kg.m <sup>2</sup> )	10.3	13.6	20.0	24.9	54.95	77.75	99.78	142.7	338	451
Mechanical constant (ms)	2.8	2.43	1.62	1.7	1.28	0.92	0.96	0.63	1.38	1.23
Torque constant-KT (N-m/A)	0.82	0.76	0.66	0.88	0.98	0.88	0.88	1.01	1.37	1.42
Voltage constant-KE (mV/(r/min))	29.5	29.2	24.2	32.2	35.0	32.0	31.0	35.5	49.0	50.0
Motor resistance (Ohm)	0.624	0.38	0.124	0.185	0.077	0.032	0.025	0.015	0.026	0.0184
Motor inductance (mH)	7.0	4.77	1.7	2.6	1.27	0.89	0.60	0.40	0.65	0.48
Electric constant (ms)	11.22	12.55	13.71	14.05	16.5	27.8	24.0	26.7	24.79	26.09
Insulation class	Class A (UL), Class B (CE)									
Insulation resistance	>100 MΩ, DC 500 V									
Insulation strength	1.8k Vac, 1 sec									
Weight (kg) (without brake)	6.3	8.6	9.4	10.5	18.5	23.5	30.5	40.5	56.4	75.0
Weight (kg) (with brake)	7.7	10.0	10.8	11.9	22.5	29.0	36.0	46.0	68.4	87.0
Radial max. loading (N)	490	490	490	490	1470	1470	1764	1764	3300	3300
Axial max. loading (N)	98	98	98	98	490	490	588	588	1100	1100
Power rating (kW/s) (with brake)	8.8	19.78	32.66	50.3	63.9	101.8	119.4	156.6	141.4	197.1
Rotor inertia ( $\times 10^{-4}$ kg.m <sup>2</sup> ) (with brake)	11.5	14.8	21.3	26.2	57.06	80.65	102.70	145.55	346.5	461.8
Mechanical constant (ms) (with brake)	3.12	2.65	1.73	1.79	1.33	0.96	0.99	0.64	1.41	1.25
Brake holding torque [Nt-m (min)] <sup>*2</sup>	10.0	10.0	10.0	10.0	25.0	55.0	55.0	55.0	115	115
Brake power consumption (at 20°C) [W]	19.0	19.0	19.0	19.0	20.4	19.9	19.9	19.9	28.8	28.8
Brake release time [ms (Max)]	10	10	10	10	10	10	10	10	10	10

ECMA Series	FΔ 13				FΔ 18				F122	
	05	08	13	18	30	45	55	75	1B	1F
Brake pull-in time [ms (Max)]	70	70	70	70	70	70	70	70	70	70
Vibration grade (μm)	15									
Operating temperature (°C)	0°C to 40°C									
Storage temperature (°C)	-10°C to 80°C									
Operating humidity	20% to 90% RH (non-condensing)									
Storage humidity	20% to 90% RH (non-condensing)									
Vibration capacity	2.5 G									
IP Rating	IP65 (use the waterproof connector and shaft seal installation (or oil seal) model)									
Approvals										

## Note:

- \*1 The rated torque is the continuous permissible torque between 0~40°C operating temperature which is suitable for the following heat sink dimension.  
 ECMA-\_\_04 / 06 / 08 : 250 mm x 250 mm x 6 mm  
 ECMA-\_\_10 : 300 mm x 300 mm x 12 mm  
 ECMA-\_\_13 : 400 mm x 400 mm x 20 mm  
 ECMA-\_\_18 : 550 mm x 550 mm x 30 mm  
 ECMA-\_\_22 : 650 mm x 650 mm x 35 mm  
 Material: Aluminum – F40, F60, F80, F100, F130, F180, F220
- \*2 The built-in brake of the servo motor is for remaining the item in stop status. Do not use it to decelerate or as the dynamic brake.
- 3 If desire to reach the max. torque limit of motor 250%, it is suggest to use the servo drive with higher watt.

## High Inertia Series

ECMA	C△06	C△08
	04□H	07□H
Rated power (kW)	0.4	0.75
Rated torque (N-m) <sup>*1</sup>	1.27	2.39
Max. torque (N-m)	3.82	7.16
Rated speed (r/min)	3000	3000
Max. speed (r/min)	5000	5000
Rated current (A)	2.6	5.1
Max. instantaneous current (A)	7.8	15.3
Max. power per second (kW/s)	21.7	19.63
Rotor inertia ( $\times 10^{-4}$ kg.m <sup>2</sup> )	0.743	2.91
Mechanical constant (ms)	1.42	1.6
Torque constant – KT (N-m/A)	0.49	0.47
Voltage constant – KE (mV/(r/min))	17.4	17.2
Armature resistance (Ohm)	1.55	0.42
Armature inductance (mH)	6.71	3.53
Electric constant (ms)	4.3	8.36
Insulation class	Class A (UL), Class B (CE)	
Insulation resistance	> 100MΩ, DC 500V	
Insulation strength	1.8k Vac, 1 sec	
Weight – without brake (kg)	1.8	3.4
Weight – with brake (kg)	2.2	3.9
Radial max. loading (N)	196	245
Axial max. loading (N)	68	98
Max. power per second (kW/s) (with brake)	21.48	19.3
Rotor inertia ( $\times 10^{-4}$ kg.m <sup>2</sup> ) (with brake)	0.751	2.96
Mechanical constant (ms) (with brake)	1.43	1.62
Brake holding torque [Nt-m (min)] <sup>*2</sup>	1.3	2.5
Brake power consumption (at 20°C) [W]	6.5	8.2
Brake release time [ms (Max)]	10	10
Brake pull-in time [ms (Max)]	70	70
Vibration grade (μm)	15	
Operating temperature (°C)	0°C ~ 40°C	

ECMA	C△06	C△08
	04□H	07□H
Storage temperature (°C)	-10°C ~ 80°C	
Operating humidity	20 ~ 90%RH (non-condensing)	
Storage humidity	20 ~ 90%RH (non-condensing)	
Vibration capacity	2.5G	
IP Rating	IP65 (use the waterproof connector and shaft seal installation (or oil seal))	
Approvals		

## Note:

- \*1 The rated torque is the continuous permissible torque between 0~40°C operating temperature which is suitable for the following heat sink dimension.  
 ECMA-\_\_04 / 06 / 08 : 250 mm x 250 mm x 6 mm  
 ECMA-\_\_10 : 300 mm x 300 mm x 12 mm  
 ECMA-\_\_13 : 400 mm x 400 mm x 20 mm  
 ECMA-\_\_18 : 550 mm x 550 mm x 30 mm  
 ECMA-\_\_22 : 650 mm x 650 mm x 35 mm  
 Material: Aluminum – F40, F60, F80, F100, F130, F180, F220
- \*2 The built-in brake of the servo motor is for remaining the item in stop status. Do not use it to decelerate or as the dynamic brake.
- 3 If desire to reach the max. torque limit of motor 250%, it is suggest to use the servo drive with higher watt.

## 11.2.2 ECMA 400V Series

### Low Inertia Series

ECMA Series	J△06	J△08	J△09		J△10		J△13
	04	07	07	10	10	20	30
Rated power (kW)	0.4	0.75	0.75	1	1.0	2.0	3.0
Rated torque (N-m) <sup>*1</sup>	1.27	2.39	2.39	3.18	3.18	6.37	9.55
Max. torque (N-m)	3.82	7.16	7.14	8.78	9.54	19.1	28.65
Rated speed (r/min)	3000		3000		3000		3000
Maximum speed (r/min)	5000		3000		5000		4500
Rated current (A)	1.62	3.07	2.16	2.4	4.15	7.09	9.8
Max. instantaneous current (A)	4.85	9.5	6.37	7.17	12.46	21.28	29.99
Power rating (kW/s)	58.2	50.4	29.6	38.6	38.2	91.2	71.8
Rotor inertia ( $\times 10^{-4}$ kg.m <sup>2</sup> )	0.277	1.13	1.93	2.62	2.65	4.45	12.7
Mechanical constant (ms)	0.47	0.66	1.56	1.06	0.77	0.58	0.99
Torque constant-KT (N-m/A)	0.79	0.78	1.12	1.29	0.77	0.9	0.97
Voltage constant-KE (mV/(r/min))	30.6	28.24	42	50.9	29.0	34.4	37.3
Armature resistance (Ohm)	3.95	1.22	3.62	2.58	0.617	0.388	0.269
Armature inductance (mH)	21.3	10.68	21.2	15.28	6.03	4.62	3.55
Electric constant (ms)	5.39	8.75	5.85	5.93	9.77	11.9	13.2
Insulation class	Class A (UL), Class B (CE)						
Insulation resistance	>100 MΩ, DC 500 V						
Insulation strength	2.3k Vac, 1 sec						
Weight (kg) (without brake)	1.6	3.0	2.9	3.8	4.3	6.2	7.8
Weight (kg) (with brake)	2.0	3.8	-	-	4.7	7.2	9.2
Radial max. loading (N)	19.6	245	245	245	490	490	490
Axial max. loading (N)	68	98	98	98	98	98	98
Power rating (kW/s) (with brake)	53.8	48.4	29.3	37.9	30.4	82	65.1
Rotor inertia ( $\times 10^{-4}$ kg.m <sup>2</sup> ) (with brake)	0.3	1.18	1.95	2.67	3.33	4.95	14.0
Mechanical constant (ms) (with brake)	0.52	0.65	1.57	1.08	0.96	0.65	1.09
Brake holding torque [Nt-m (min)] <sup>*2</sup>	1.3	2.5	2.5	2.5	8	8	10.0
Brake power consumption (at 20°C) [W]	6.5	8.5	8.2	8.2	18.5	18.5	19.0

ECMA Series	J△06	J△08	J△09		J△10		J△13
	04	07	07	10	10	20	30
Brake release time [ms (Max)]	10	10	10	10	10	10	10
Brake pull-in time [ms (Max)]	70	70	70	70	70	70	70
Vibration grade (μm)	15						
Operating temperature (°C)	0°C to 40°C						
Storage temperature (°C)	-10°C to 80°C						
Operating humidity	20% to 90% RH (non-condensing)						
Storage humidity	20% to 90% RH (non-condensing)						
Vibration capacity	2.5 G						
IP Rating	IP65 (use the waterproof connector and shaft seal installation (or oil seal) model)						
Approvals							

## Note:

- \*1 The rated torque is the continuous permissible torque between 0~40°C operating temperature which is suitable for the following heat sink dimension.  
 ECMA-\_\_08 : 250 mm x 250 mm x 6 mm  
 ECMA-\_\_13 : 400 mm x 400 mm x 20 mm  
 ECMA-\_\_18 : 550 mm x 550 mm x 30 mm  
 Material: Aluminum – F80, F130, F180
- \*2 The built-in brake of the servo motor is for remaining the item in stop status. Do not use it to decelerate or as the dynamic brake.

## Medium Inertia Series

ECMA Series	K△13				K△18
	05	10	15	20	20
Rated power (kW)	0.5	1.0	1.5	2.0	2.0
Rated torque (N-m) <sup>*1</sup>	2.39	4.77	7.16	9.55	9.55
Max. torque (N-m)	7.16	14.32	21.48	28.65	28.65
Rated speed (r/min)	2000				
Maximum speed (r/min)	3000				
Rated current (A)	1.7	3.52	5.02	6.66	6.6
Max. instantaneous current (A)	5.2	10.56	15.06	19.98	19.88
Power rating (kW/s)	6.99	27.1	45.9	62.5	26.3
Rotor inertia (× 10 <sup>-4</sup> kg.m <sup>2</sup> )	8.17	8.41	11.18	14.59	34.68
Mechanical constant (ms)	2.08	1.80	1.24	1.04	1.74
Torque constant-KT (N-m/A)	1.41	1.35	1.43	1.43	1.45
Voltage constant-KE (mV/(r/min))	51.5	53.2	55.0	55.0	54.0
Armature resistance (Ohm)	1.76	1.47	0.83	0.57	0.376
Armature inductance (mH)	22.4	17.79	11.67	8.29	7.87
Electric constant (ms)	12.73	12.04	14.04	14.39	20.9
Insulation class	Class A (UL), Class B (CE)				
Insulation resistance	>100 MΩ, DC 500 V				
Insulation strength	2.3k Vac, 1 sec				
Weight (kg) (without brake)	6.8	7.0	7.5	7.8	13.5
Weight (kg) (with brake)	8.2	8.4	8.9	9.2	17.5
Radial max. loading (N)	490	490	490	490	1176
Axial max. loading (N)	98	98	98	98	490
Power rating (kW/s) (with brake)	6.39	24.9	43.1	59.7	24.1
Rotor inertia (× 10 <sup>-4</sup> kg.m <sup>2</sup> ) (with brake)	8.94	9.14	11.90	15.88	37.86
Mechanical constant (ms) (with brake)	2.28	1.96	1.32	1.13	1.9
Brake holding torque [Nt-m (min)] <sup>*2</sup>	10.0	10.0	10.0	10.0	25.0
Brake power consumption (at 20°C) [W]	19.0	19.0	19.0	19.0	20.4
Brake release time [ms (Max)]	10	10	10	10	10



ECMA Series	K△13				K△18
	05	10	15	20	20
Brake pull-in time [ms (Max)]	70	70	70	70	70
Vibration grade (μm)	15				
Operating temperature (°C)	0°C ~ 40°C				
Storage temperature (°C)	-10°C~80°C				
Operating humidity	20% to 90% RH (non-condensing)				
Storage humidity	20% to 90% RH (non-condensing)				
Vibration capacity	2.5G				
IP Rating	IP65(use the waterproof connector and shaft seal installation (or oil seal) model)				
Approvals					

## Note:

- \*1 The rated torque is the continuous permissible torque between 0~40°C operating temperature which is suitable for the following heat sink dimension.  
 ECMA-\_\_08 : 250 mm x 250 mm x 6 mm  
 ECMA-\_\_13 : 400 mm x 400 mm x 20 mm  
 ECMA-\_\_18 : 550 mm x 550 mm x 30 mm  
 Material: Aluminum – F80, F130, F180
- \*2 The built-in brake of the servo motor is for remaining the item in stop status. Do not use it to decelerate or as the dynamic brake.

## Medium-High Inertia Series

ECMA Series	LΔ 18			
	30	45	55	75
Rated power (kW)	3.0	4.5	5.5	7.5
Rated torque (N-m) <sup>*1</sup>	19.10	28.65	35.0	47.74
Max. torque (N-m)	57.29	71.62	87.53	119.36
Rated speed (r/min)	1500			
Max. speed (r/min)	3000			
Rated current (A)	11.53	20.8	22.37	27.3
Max. instantaneous current (A)	34.6	52.0	56.0	68.3
Power rating (kW/s)	66.4	105.5	122.9	159.7
Rotor inertia ( $\times 10^{-4}$ kg.m <sup>2</sup> )	54.95	77.75	99.78	142.7
Mechanical constant (ms)	1.11	0.94	0.88	0.77
Torque constant-KT (N-m/A)	1.66	1.38	1.56	1.75
Voltage constant-KE (mV/(r/min))	64.4	53.0	58.9	66.4
Motor resistance (Ohm)	0.21	0.09	0.07	0.06
Motor inductance (mH)	4.94	2.36	2.2	1.7
Electric constant (ms)	23.97	28.07	27.6	28.29
Insulation class	-			
Insulation resistance	>100 MΩ, DC 500 V			
Insulation strength	2.3k Vac, 1 sec			
Weight (kg) (without brake)	18.5	23.5	30.5	40.5
Weight (kg) (with brake)	22.5	29	36	46
Radial max. loading (N)	1470	1470	1764	1764
Axial max. loading (N)	490	490	588	588
Power rating (kW/s) (with brake)	63.9	101.8	119.4	156.6
Rotor inertia ( $\times 10^{-4}$ kg.m <sup>2</sup> ) (with brake)	57.06	80.65	102.70	145.5
Mechanical constant (ms) (with brake)	1.16	0.95	0.91	0.79
Brake holding torque [Nt-m (min)]	25.0	55.0	55.0	55.0
Brake power consumption (at 20°C) [W]	20.4	19.9	19.9	19.9
Brake release time [ms (Max)]	10	10	10	10
Brake pull-in time [ms (Max)]	70	70	70	70
Vibration grade (μm)	15			

ECMA Series	LΔ 18			
	30	45	55	75
Operating temperature (°C)	0°C to 40°C			
Storage temperature (°C)	-10°C to 80°C			
Operating humidity	20% to 90% RH (non-condensing)			
Storage humidity	20% to 90% RH (non-condensing)			
Vibration capacity	2.5 G			
IP Rating	IP65 (use the waterproof connector and shaft seal installation (or oil seal) model)			
Approvals				

## Note:

- \*1 The rated torque is the continuous permissible torque between 0~40°C operating temperature which is suitable for the following heat sink dimension.  
 ECMA-\_\_08 : 250 mm x 250 mm x 6 mm  
 ECMA-\_\_13 : 400 mm x 400 mm x 20 mm  
 ECMA-\_\_18 : 550 mm x 550 mm x 30 mm  
 ECMA-\_\_22: 650 mm x 650 mm x 35 mm  
 Material type: Aluminum – F80, F130, F180, F220
- \*2 The built-in brake of the servo motor is for remaining the item in stop status. Do not use it to decelerate or as the dynamic brake.

## High Inertia Series

ECMA Series	L $\Delta$ 13			M $\Delta$ 13
	05	08	13	09
Rated power (kW)	0.5	0.85	1.3	0.9
Rated torque (N-m) <sup>*1</sup>	3.18	5.39	8.34	8.59
Max. torque (N-m)	8.92	13.8	23.3	21.48
Rated speed (r/min)	1500			1000
Max. speed (r/min)	3000			2000
Rated current (A)	2.1	3.4	5.02	4.4
Max. constant current (A)	6.1	8.85	15	13.1
Power rating (kW/s)	7.72	17.0	29.47	66
Rotor inertia ( $\times 10^{-4}$ kg.m <sup>2</sup> )	13.1	17.1	23.6	11.18
Mechanical constant (ms)	2.3	1.76	1.44	1.21
Torque constant-KT (N-m/A)	1.5	1.59	1.66	1.95
Voltage constant-KE (mV/(r/min))	55.5	58.9	61.1	71.7
Armature resistance (Ohm)	1.41	0.92	0.59	1.45
Armature inductance (mH)	20	14.1	9.54	23.3
Electrical constant (ms)	14.1	15.33	16.17	16.07
Insulation class	Class A (UL), Class B (CE)			
Insulation resistance	> 100 M $\Omega$ , DC 500 V			
Insulation strength	2.3k Vac, 1 sec			
Weight (kg) (without brake)	6.8	8.6	10.7	7.5
Weight (kg) (with brake)	-	10	--	8.9
Radial max. loading (N)	490	490	490	490
Axial max. loading (N)	98	98	98	98
Power rating (kW/s) (with brake)	7.02	14.82	27.82	--
Rotor inertia ( $\times 10^{-4}$ kg.m <sup>2</sup> ) (with brake)	14.4	19.6	25	--
Mechanical time constant (ms) (with brake)	2.54	2.02	1.52	--
Brake holding torque [Nt-m (min)] <sup>*2</sup>	10.0	10.0	10.0	--
Brake power consumption (at 20°C)[W]	19.0	19.0	19.0	--
Brake release time [ms (Max)]	10	10	10	--
Brake pull-in time [ms (Max)]	70	70	70	--
Vibration grade ( $\mu$ m)	15			
Operating temperature (°C)	0°C ~ 40°C			
Storage temperature (°C)	-10°C ~ 80°C			

ECMA Series	LΔ 13			MΔ 13
	05	08	13	09
Operating humidity	20 ~ 90%RH (non-condensing)			
Storage humidity	20 ~ 90%RH (non-condensing)			
Vibration capacity	2.5 G			
IP Rating	IP65 (use the waterproof connector and shaft seal installation (or oil seal) model)			
Approvals				

Note:

\*1 The rated torque is the continuous permissible torque between 0~40°C operating temperature which is suitable for the following heat sink dimension.

ECMA-\_\_ 08 : 250 mm x 250 mm x 6 mm

ECMA-\_\_ 13 : 400 mm x 400 mm x 20 mm

ECMA-\_\_ 18 : 550 mm x 550 mm x 30 mm

ECMA-\_\_ 22 : 650 mm x 650 mm x 35 mm

Material type: Aluminum –F80, F130, F180, F220

\*2 The built-in brake of the servo motor is for remaining the item in stop status. Do not use it to decelerate or as the dynamic brake.

3 Model of ECMA-L11308 is applying for UL approval.

# 11.3 Torque Features (T-N Curves)

## 11.3.1 220 V Series

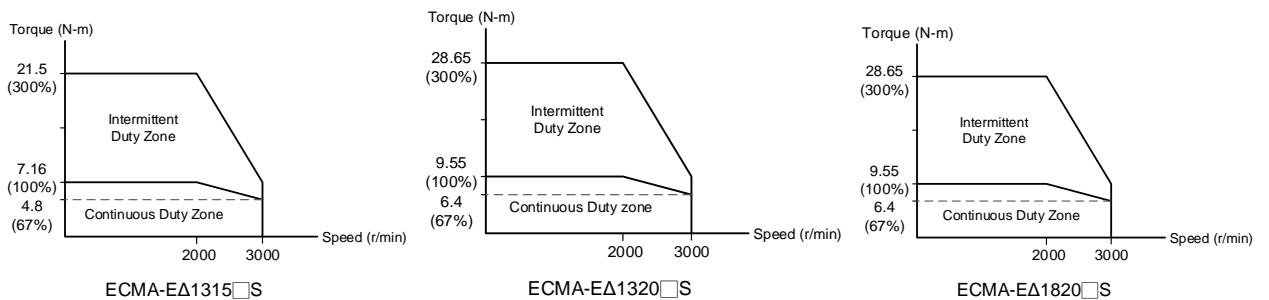
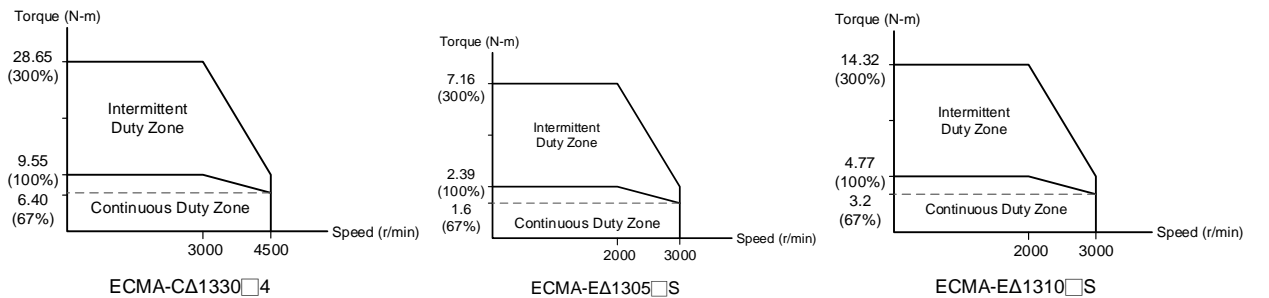
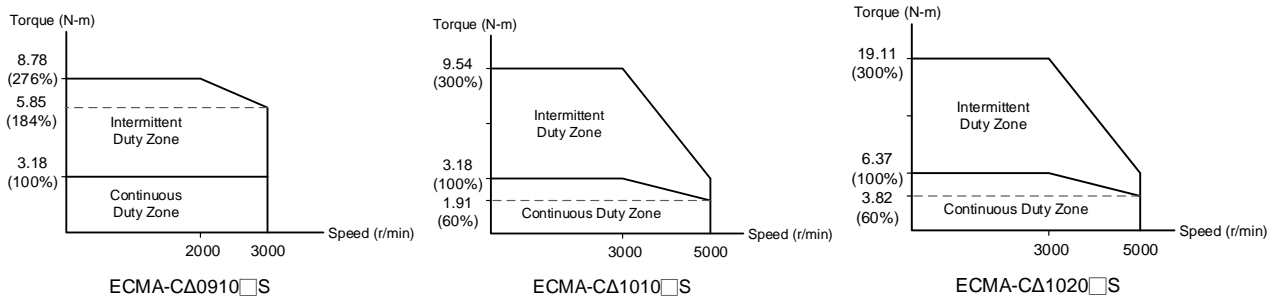
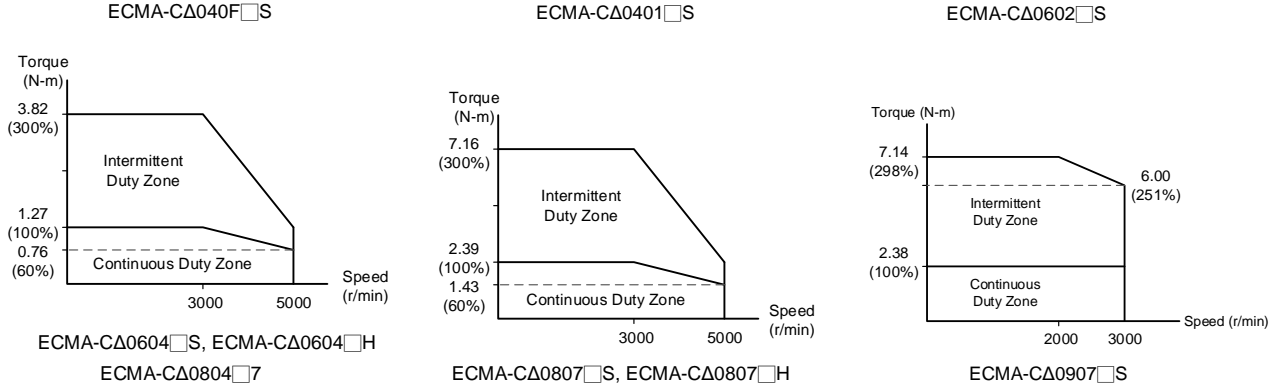
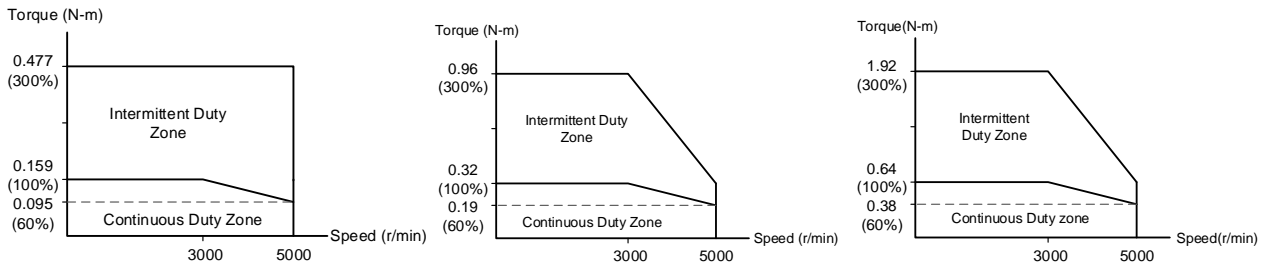

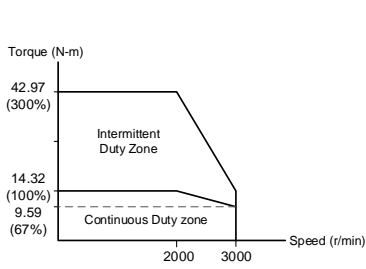

ECMA-EΔ1830□S

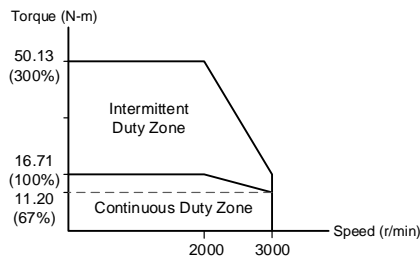

ECMA-EΔ1835□S

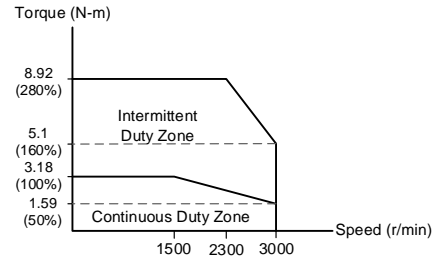

ECMA-FΔ1305□S

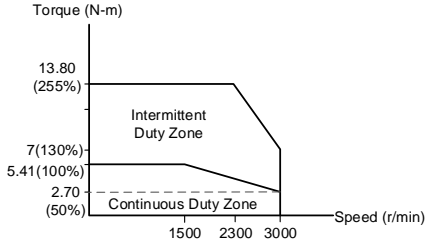

ECMA-FΔ1308□S

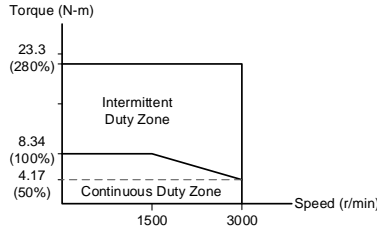

ECMA-FΔ1313□S

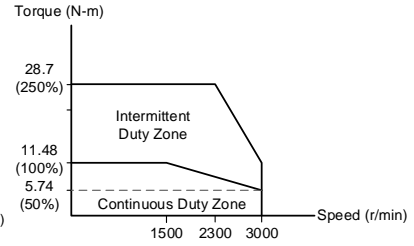

ECMA-FΔ1318□S

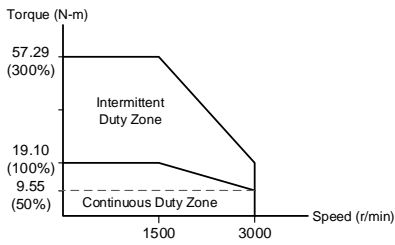

ECMA-FΔ1830□S

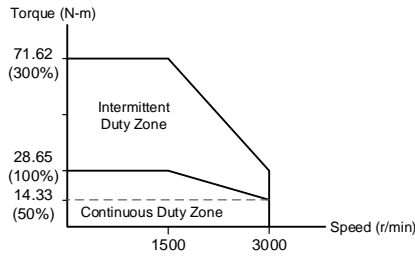

ECMA-FΔ1845□S

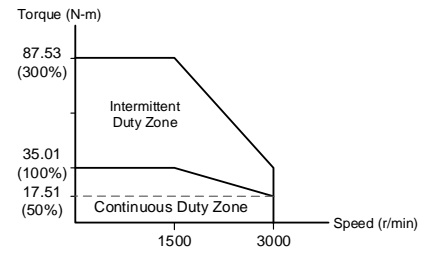

ECMA-FΔ1855□S

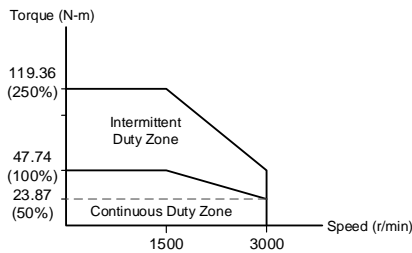

ECMA-FΔ1875□S

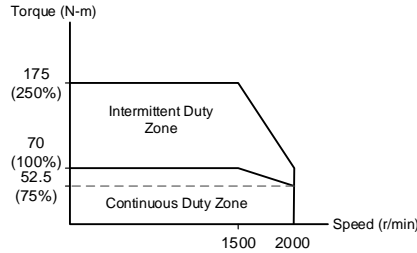

ECMA-F1221B□3

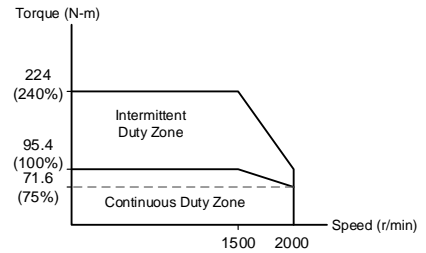

ECMA-F1221F□S

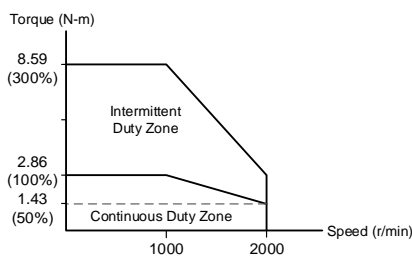

ECMA-GΔ1303□S

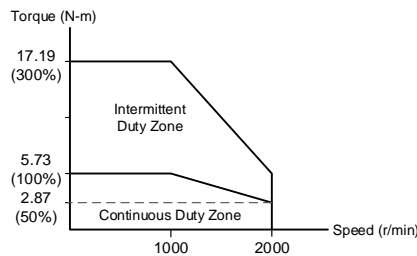

ECMA-GΔ1306□S

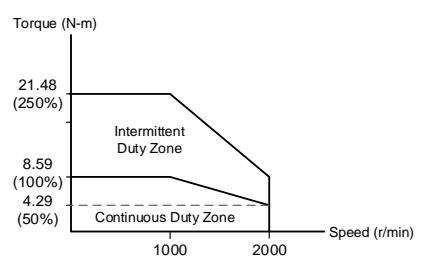

ECMA-GΔ1309□S

### 11.3.2 400 V Series

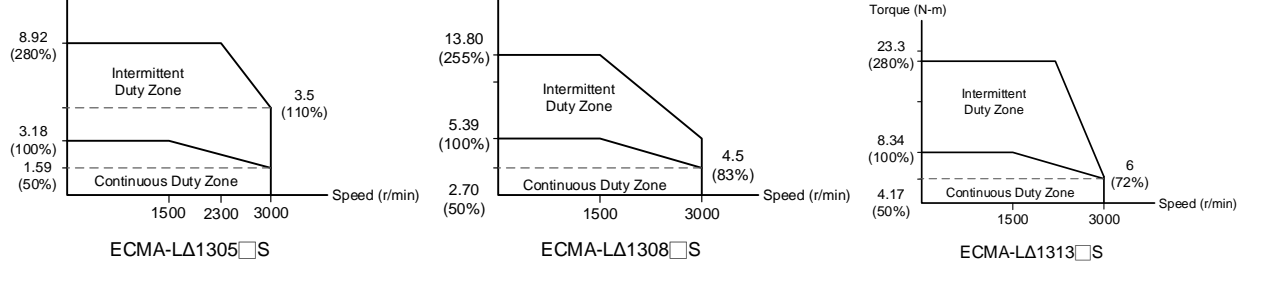
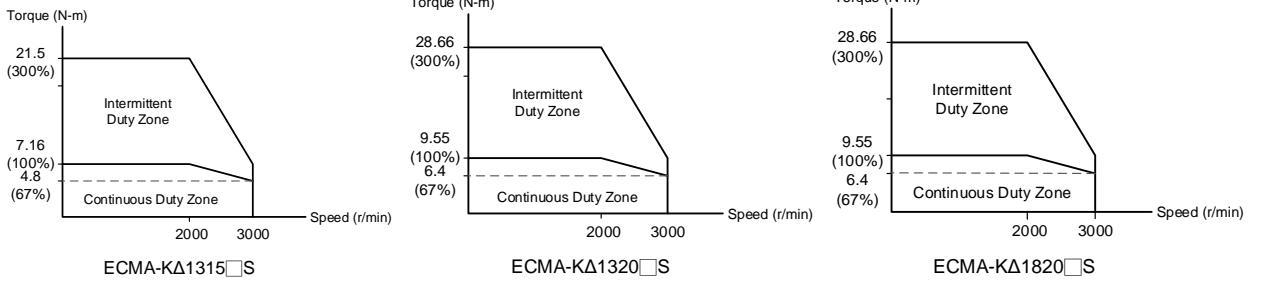
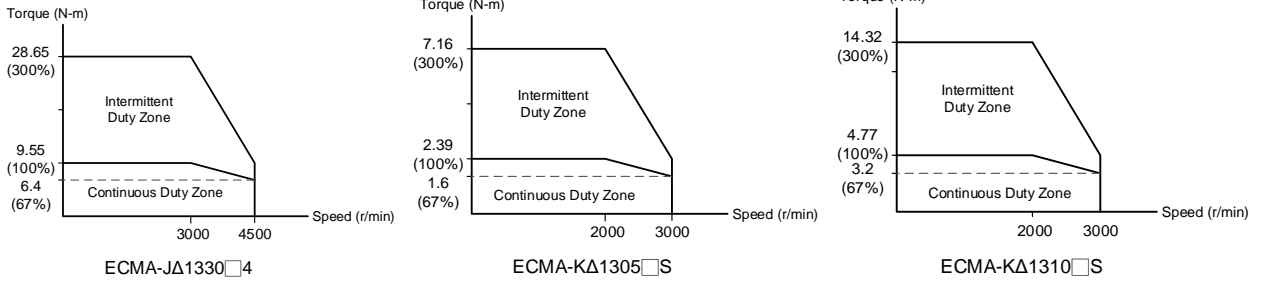
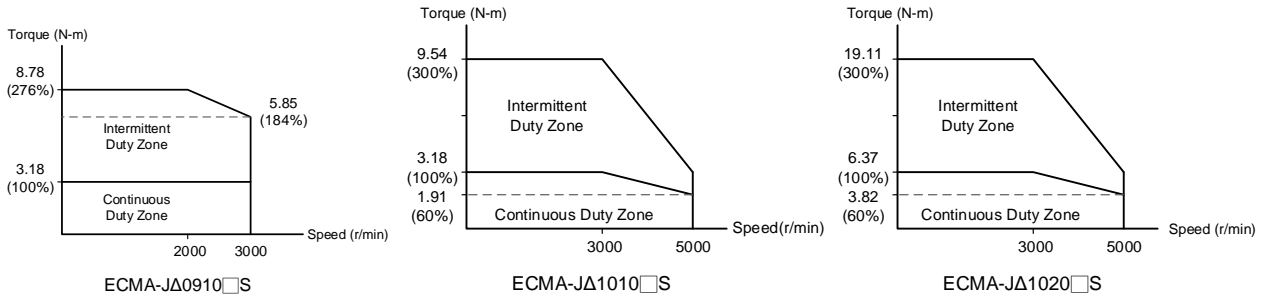
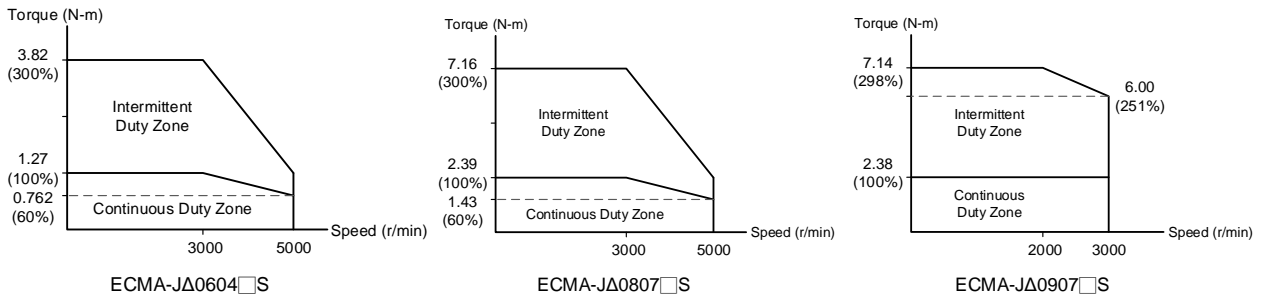



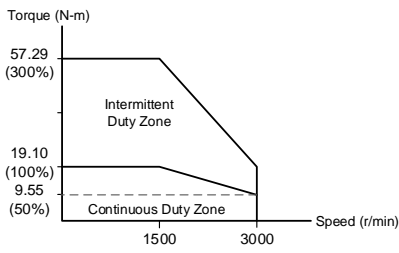

ECMA-LΔ1830□S

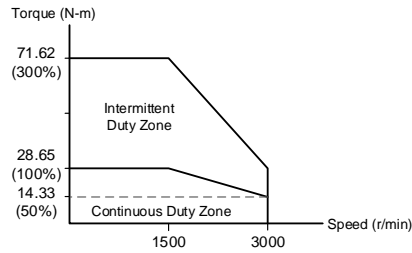

ECMA-LΔ1845□S

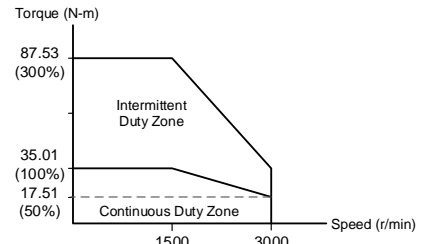

ECMA-LΔ1855□S

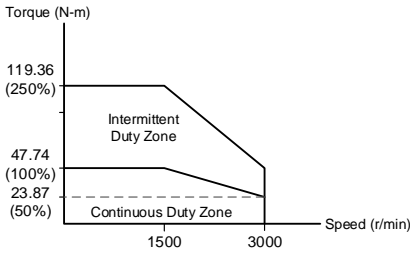

ECMA-LΔ1875□S

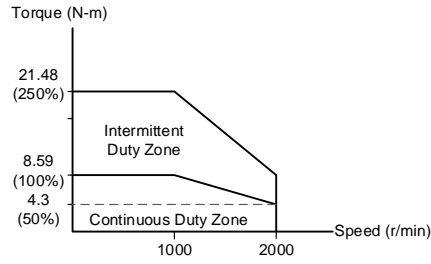

ECMA-MΔ1309□S

## 11.4 Overload Features

### Definition of overload protection

The overload protection is to prevent the motor in overheat status.

### Cause of overload

- 1) When the motor operates over the rated torque, the operation time is too long
- 2) The inertia ratio is set too big and frequently accelerate / decelerate
- 3) Connection error between the power cable and encoder wiring
- 4) Servo gain setting error and cause resonance of the motor
- 5) The motor with brake operates without releasing the brake

### The graph of load and operating time

#### Low Inertia Series (ECMA C1, J1 Series)

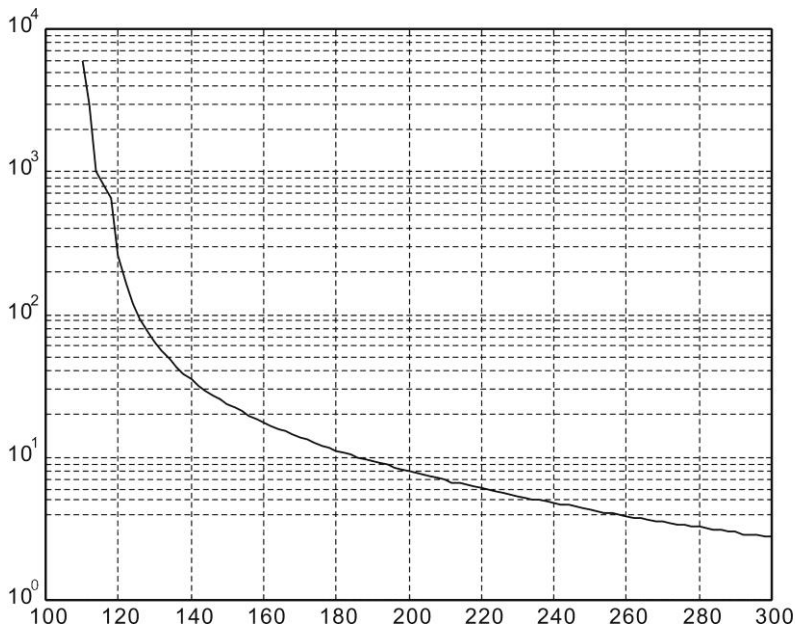

Load	Operating Time
120%	263.8s
140%	35.2s
160%	17.6s
180%	11.2s
200%	8s
220%	6.1s
240%	4.8s
260%	3.9s
280%	3.3s
300%	2.8s

**Medium and Medium-High Inertia Series (ECMA E1, F1, K1 and L1 Series)**

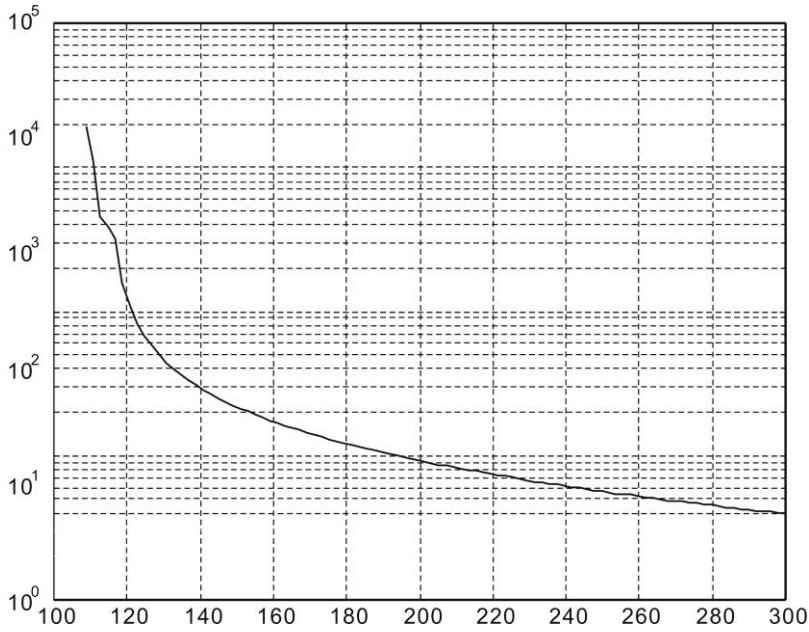

Load	Operating Time
120%	527.6s
140%	70.4s
160%	35.2s
180%	22.4s
200%	16s
220%	12.2s
240%	9.6s
260%	7.8s
280%	6.6s
300%	5.6s

**High Inertia Series (ECMA G1 Series)**

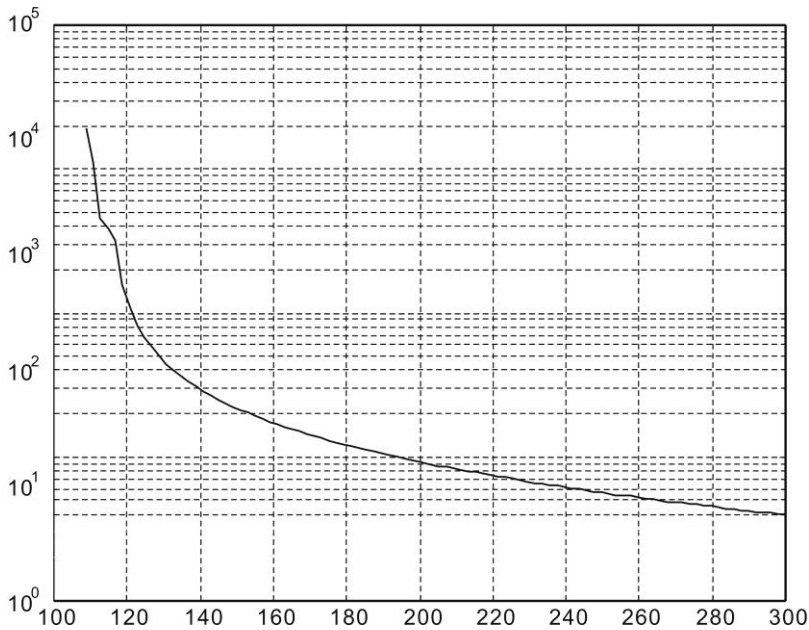

Load	Operating Time
120%	527.6s
140%	70.4s
160%	35.2s
180%	22.4s
200%	16s
220%	12.2s
240%	9.6s
260%	7.8s
280%	6.6s
300%	5.6s

## 11.5 Dimensions of Servo Drive

### 11.5.1 220 V Series

ASD-A2-0121; ASD-A2-0221; ASD-A2-0421 (100 W ~ 400 W)

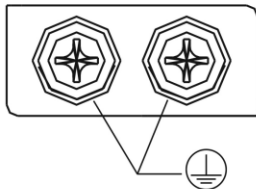
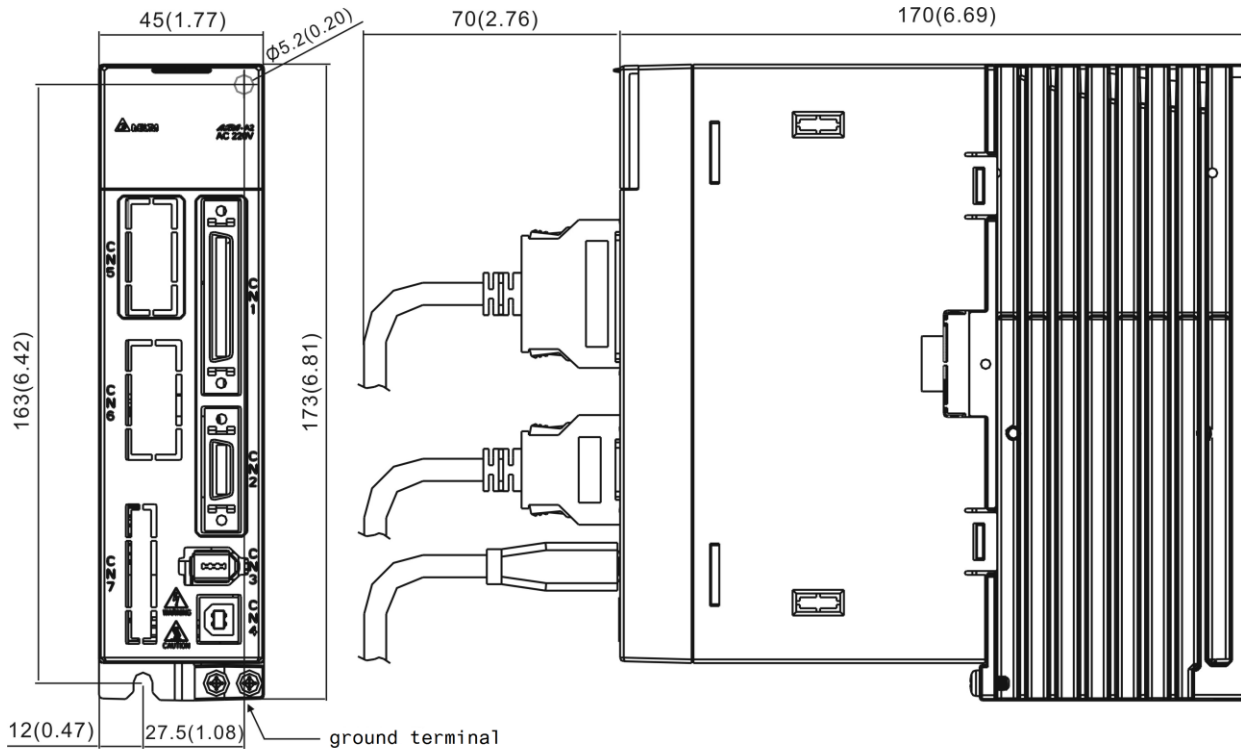

screw: M4 x 0.7  
tightening torque: 14 (kgf-cm)

Weight
1.5 (3.3)



- 1) Dimensions are in millimeters (inches); Weights are in kilograms (kg) and (pounds (lbs)).
- 2) Dimensions and weights of the servo drive may be revised without prior notice.

**ASD-A2-0721; ASD-A2-1021; ASD-A2-1521 (750 W ~ 1.5 kW)**

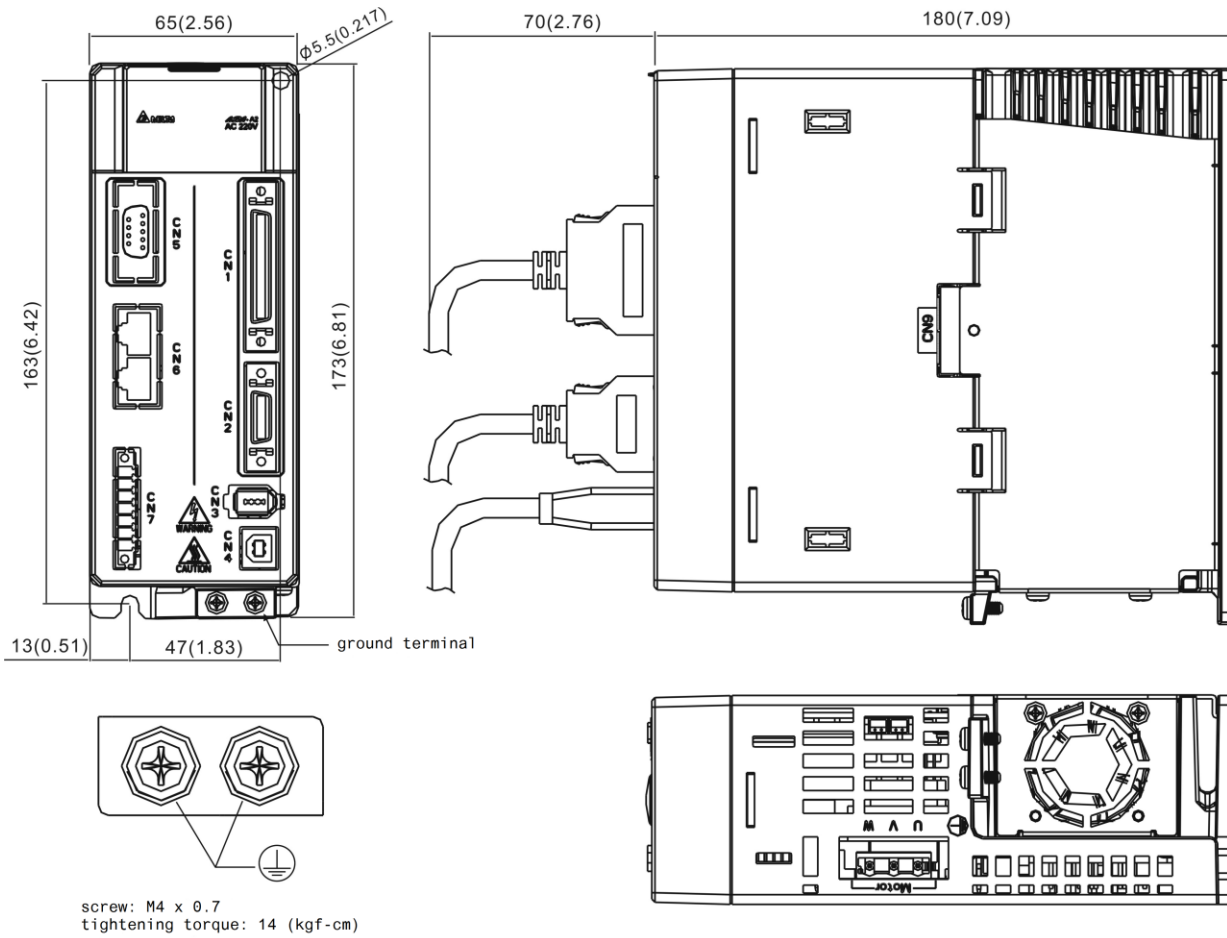

Weight
2.0 (4.4)



- 1) Dimensions are in millimeters (inches); Weights are in kilograms (kg) and (pounds (lbs)).
- 2) Dimensions and weights of the servo drive may be revised without prior notice.

**ASD-A2-2023; ASD-A2-3023 (2 kW ~ 3 kW)**

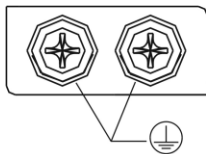
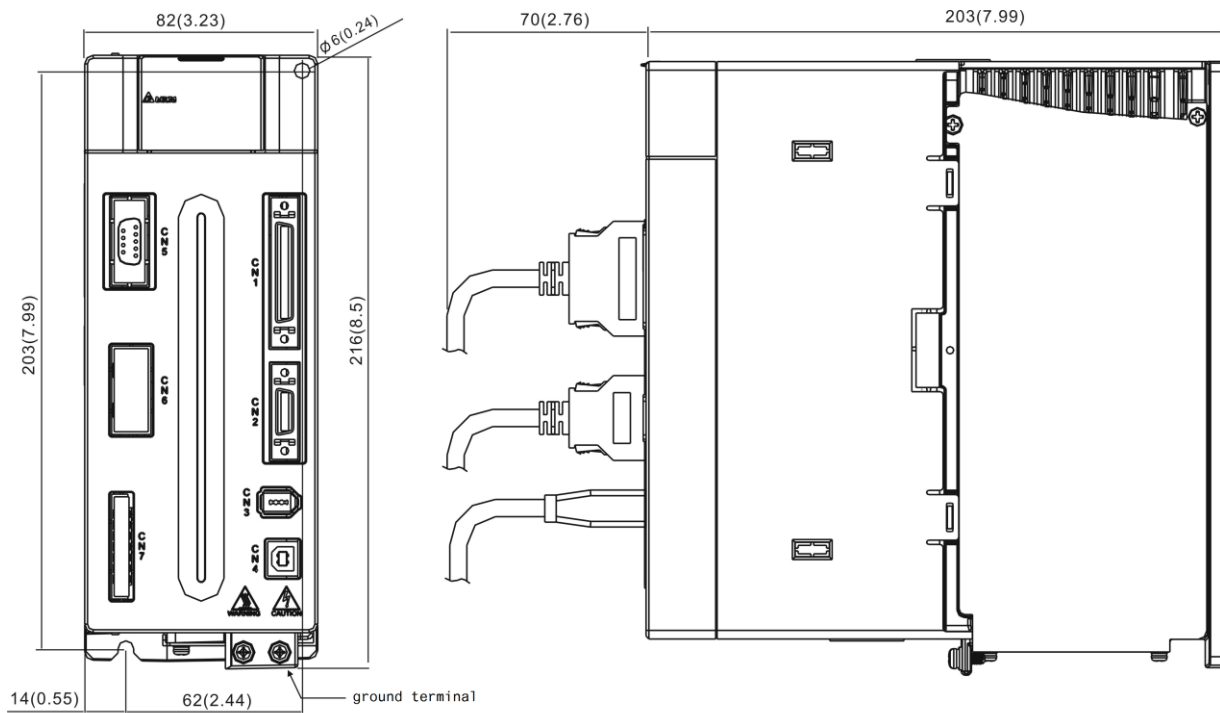

screw: M4 x 0.7  
tightening torque: 14 (kgf-cm)

<b>Weight</b>
2.89 (6.36)



- 1) Dimensions are in millimeters (inches); Weights are in kilograms (kg) and (pounds (lbs)).
- 2) Dimensions and weights of the servo drive may be revised without prior notice.

**ASD-A2-4523 (4.5 kW)**

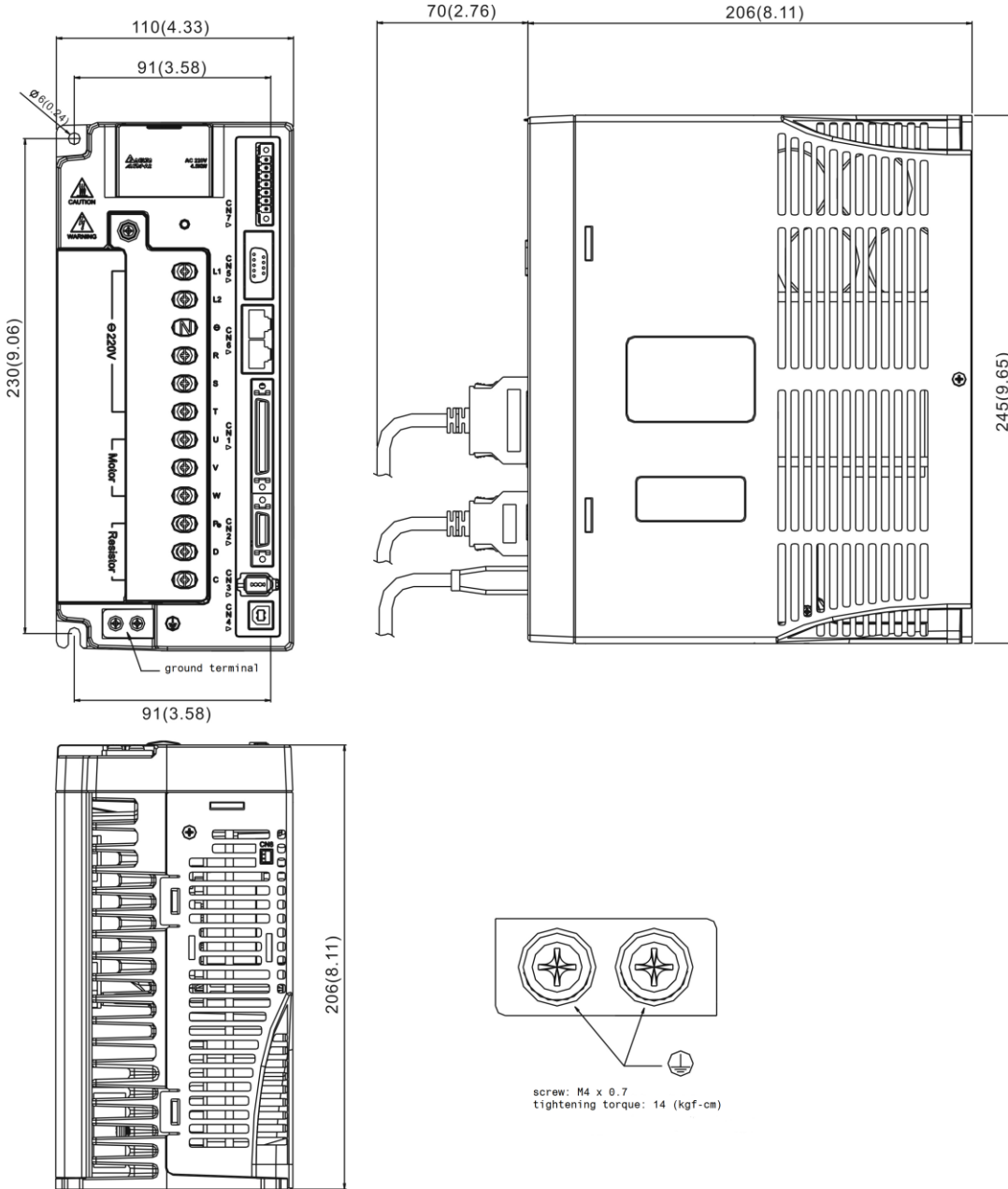

Weight
4.4 (10.0)



- 1) Dimensions are in millimeters (inches); Weights are in kilograms (kg) and (pounds (lbs)).
- 2) Dimensions and weights of the servo drive may be revised without prior notice.

**ASD-A2-5523 (5.5 kW)**

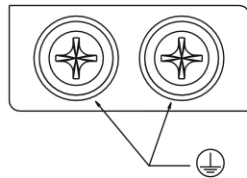
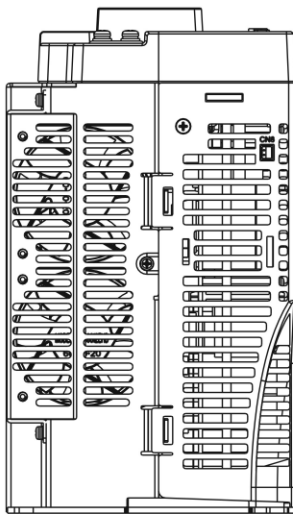
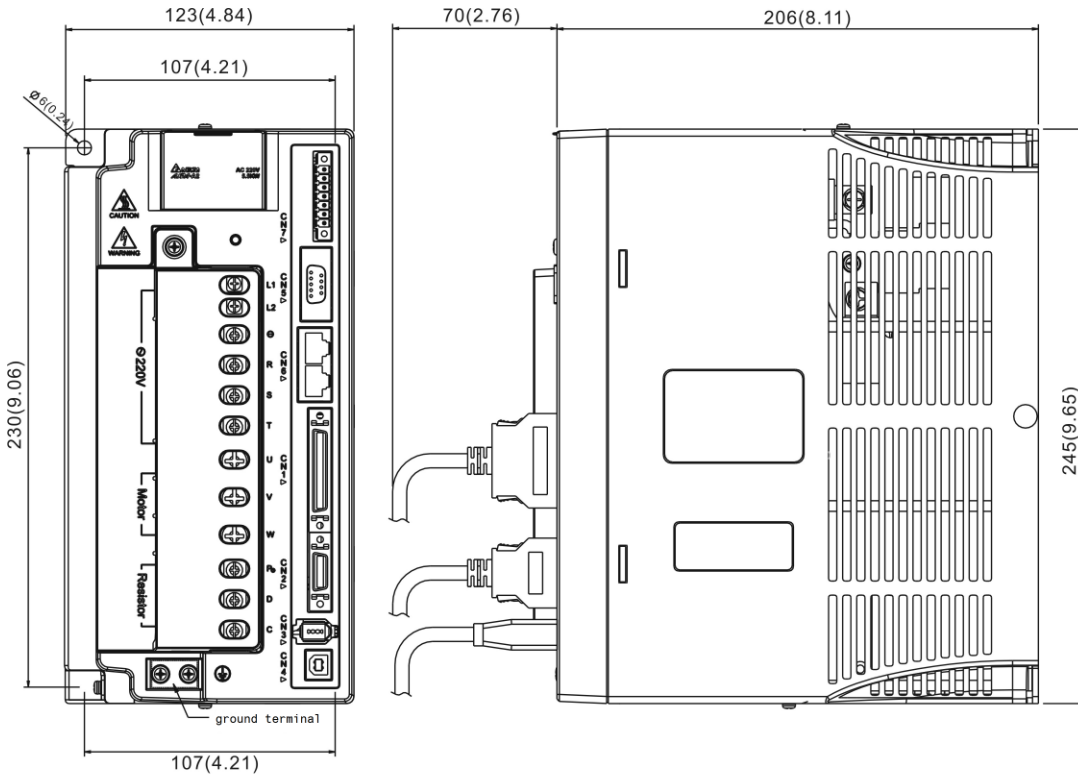

screw: M4 x 0.7  
tightening torque: 14 (kgf-cm)

Weight
5.5 (12.1)



- 1) Dimensions are in millimeters (inches); Weights are in kilograms (kg) and (pounds (lbs)).
- 2) Dimensions and weights of the servo drive may be revised without prior notice.



**ASD-A2-7523 (7.5 kW)**

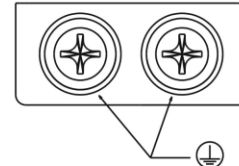
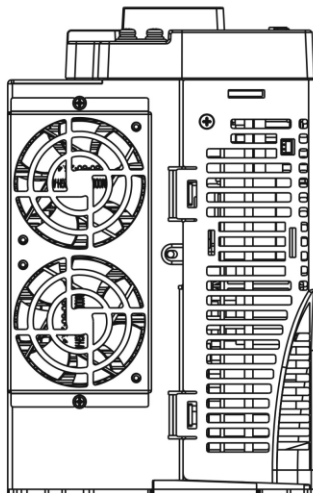
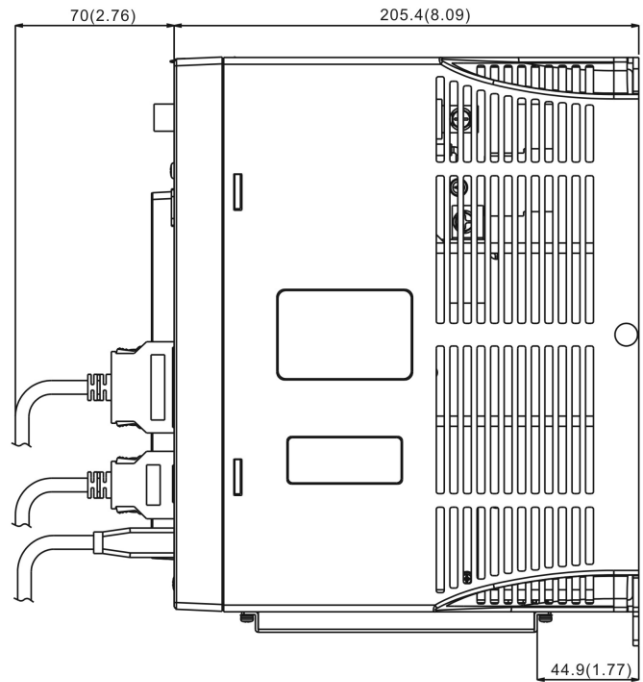
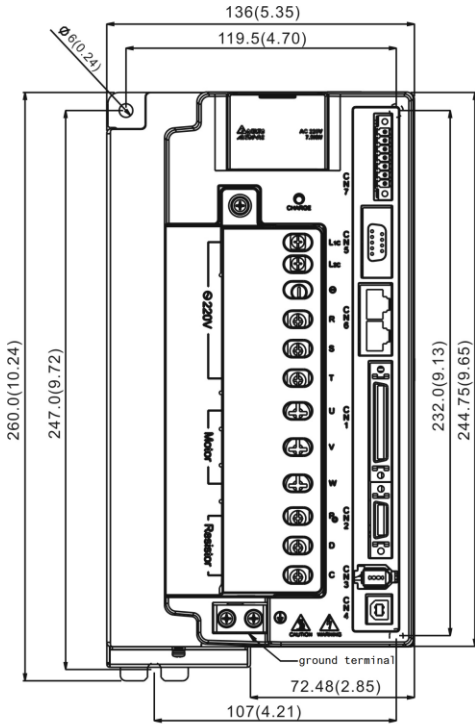

screw: M4 x 0.7  
tightening torque: 14 (kgf-cm)

Weight
5.9 (13)



- 1) Dimensions are in millimeters (inches); Weights are in kilograms (kg) and (pounds (lbs)).
- 2) Dimensions and weights of the servo drive may be revised without prior notice.

ASD-A2-1B23 (11 kW); ASD-A2-1F23 (15 kW)

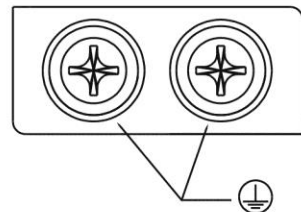
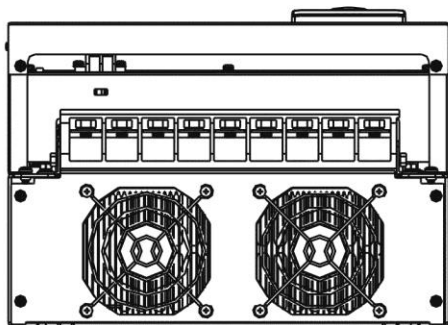
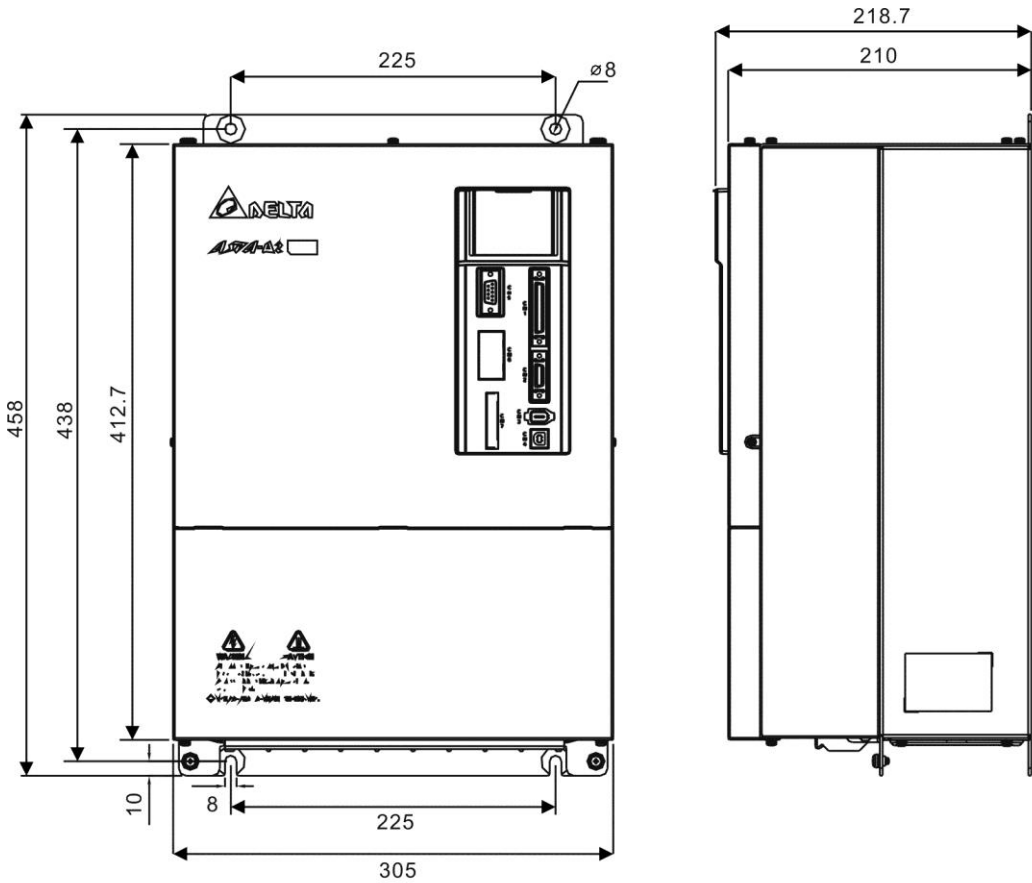

Screw: M 4 X 0.7  
Screw Torque: 14 (kgf-cm)

Weight
20 (44)



- 1) Dimensions are in millimeters (inches); Weights are in kilograms (kg) and (pounds (lbs)).
- 2) Dimensions and weights of the servo drive may be revised without prior notice.

### 11.5.2 400 V Series

ASD-A2-0743; ASD-A2-1043; ASD-A2-1543 (750 W ~ 1.5 kW)

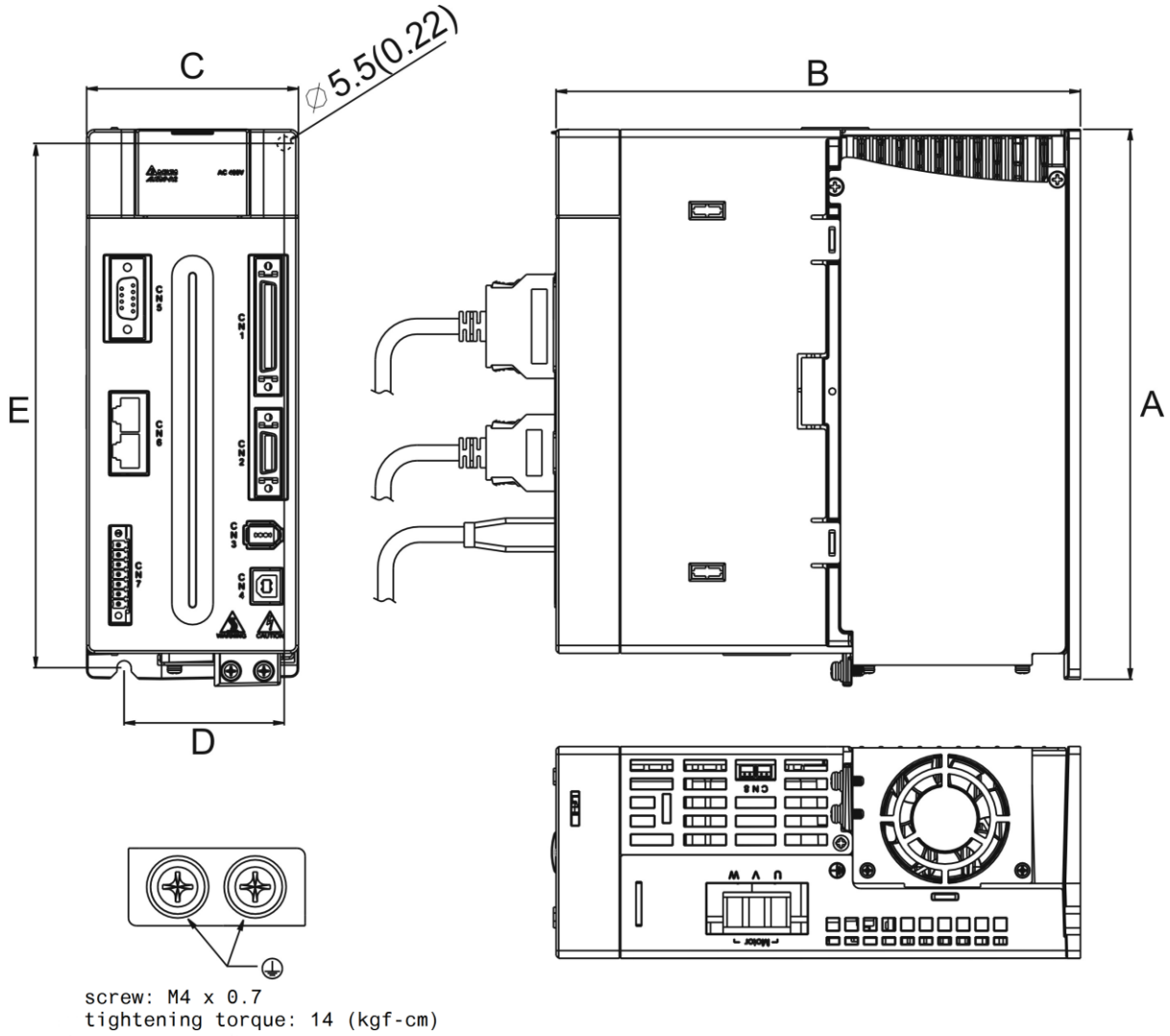

**ASD-A2-2043; ASD-A2-3043, ASD-A2-4543; ASD-A2-5543 (2 kW ~ 5.5 kW)**

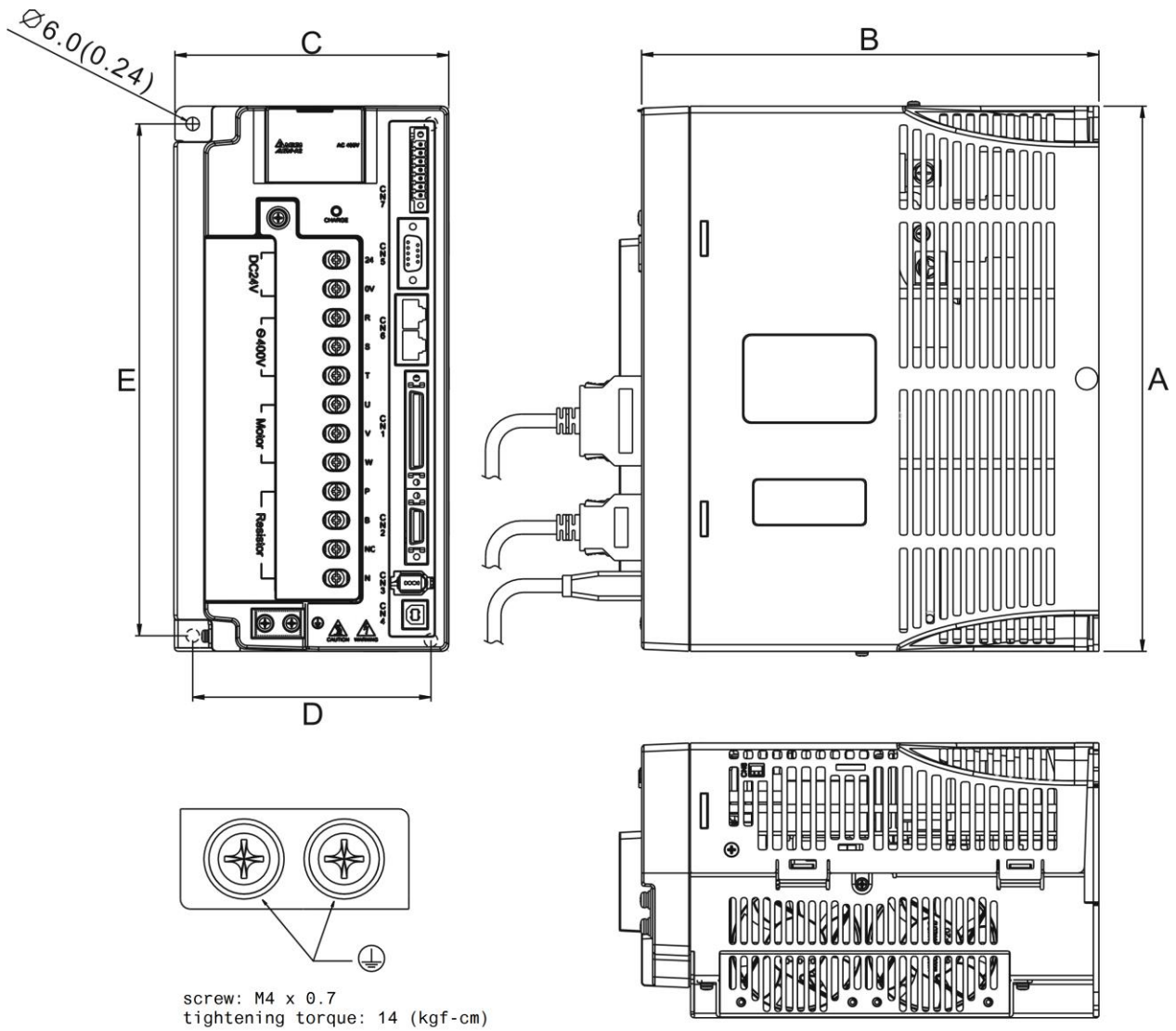

Power	A	B	C	D	E	Weight
750 W~ 1.5 kW	216 (8.50)	203 (7.99)	82 (3.23)	62 (2.44)	203 (7.99)	2.89 (6.36)
2 kW ~ 5.5 kW	245 (9.65)	205.4 (8.09)	123 (4.88)	107 (4.21)	230 (9.06)	5.5 (12.1)

**ASD-A2-7543 (7.5 kW)**

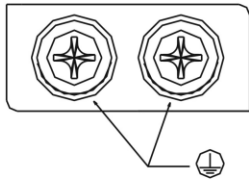
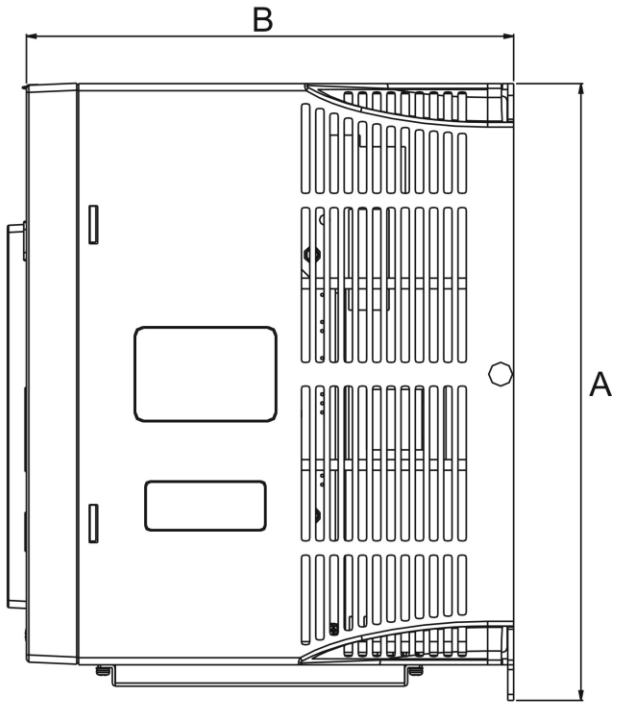
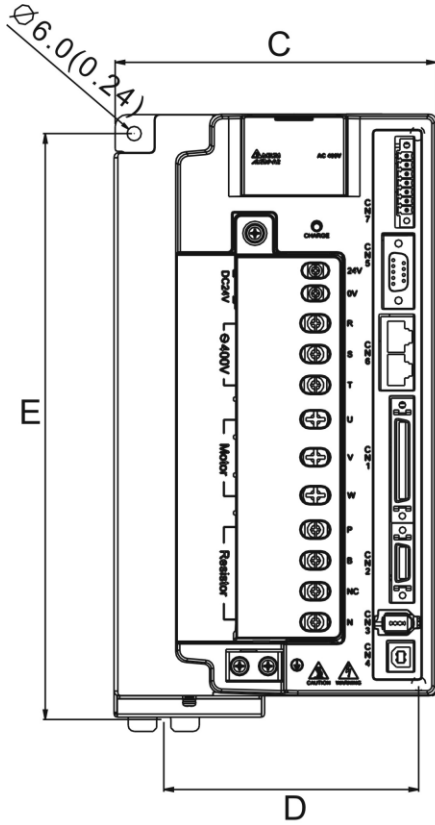

screw: M4 x 0.7  
tightening torque: 14 (kgf-cm)

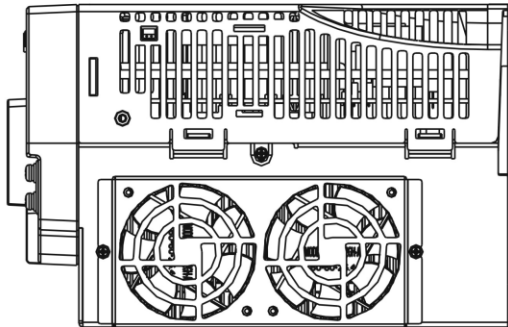

Power	A	B	C	D	E	Weight
7.5 kW	254.2 (10.01)	205.5 (8.09)	136 (5.35)	107 (4.21)	247 (9.72)	5.5 (12.1)



- 1) Dimensions are in millimeters (inches)
- 2) Weights are in kilograms (kg) and (pounds (lbs)).
- 3) The servo drive images shown here may differ from actual product appearance. Please refer to actual product appearance.
- 4) Actual measured values are in metric units. Dimensions and weights in (imperial units) are for reference only.

## 11.6 Dimensions of Servo Motors (ECMA Series)

### 11.6.1 220 V Series

Motor Frame Size: 86 mm and below Models (Units: mm)

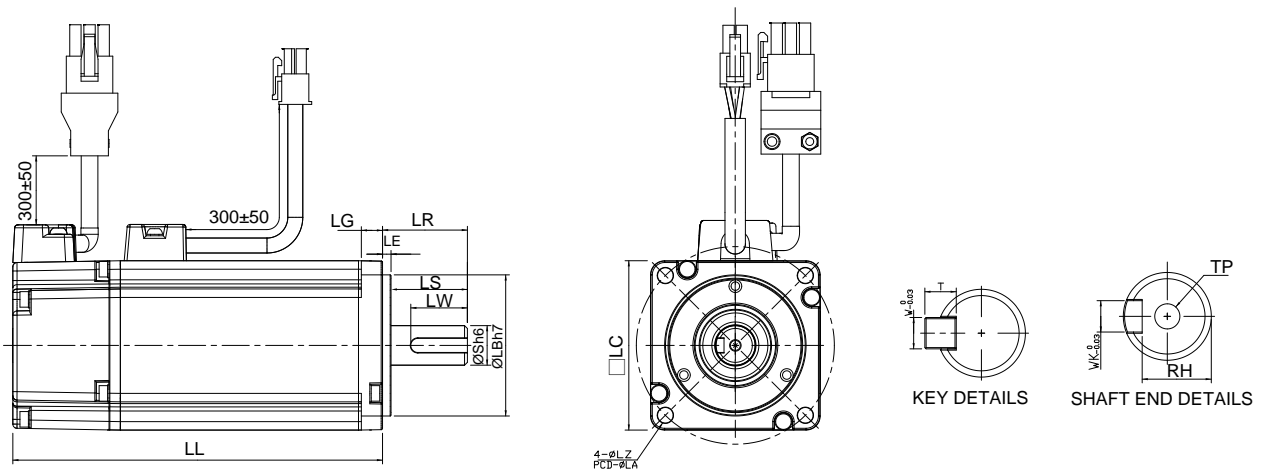

Model	C1040F□S	C△ 0401□S	C△ 0602□S	C△ 0604□S	C△0604□H
LC	40	40	60	60	60
LZ	4.5	4.5	5.5	5.5	5.5
LA	46	46	70	70	70
S	8 <sup>+0</sup> <sub>-0.009</sub>	8 <sup>+0</sup> <sub>-0.009</sub>	14 <sup>+0</sup> <sub>-0.011</sub>	14 <sup>+0</sup> <sub>-0.011</sub>	14 <sup>+0</sup> <sub>-0.011</sub>
LB	30 <sup>+0</sup> <sub>-0.021</sub>	30 <sup>+0</sup> <sub>-0.021</sub>	50 <sup>+0</sup> <sub>-0.025</sub>	50 <sup>+0</sup> <sub>-0.025</sub>	50 <sup>+0</sup> <sub>-0.025</sub>
LL (without brake)	79.1	100.6	105.5	130.7	145.8
LL (with brake)	--	136.8	141.6	166.8	176.37
LS	20	20	27	27	27
LR	25	25	30	30	30
LE	2.5	2.5	3	3	3
LG	5	5	7.5	7.5	7.5
LW	16	16	20	20	20
RH	6.2	6.2	11	11	11
WK	3	3	5	5	5
W	3	3	5	5	5
T	3	3	5	5	5
TP	M3 Depth 8	M3 Depth 8	M4 Depth 15	M4 Depth 15	M4 Depth 15

Model	C△0804□7	C△0807□S	C△0807□H	C△0907□S	C△0910□S
LC	80	80	80	86	86
LZ	6.6	6.6	6.6	6.6	6.6
LA	90	90	90	100	100
S	14 <sup>(+0/-0.011)</sup>	19 <sup>(+0/-0.013)</sup>	19 <sup>(+0/-0.013)</sup>	16 <sup>(+0/-0.011)</sup>	16 <sup>(+0/-0.011)</sup>
LB	70 <sup>(+0/-0.030)</sup>	70 <sup>(+0/-0.030)</sup>	70 <sup>(+0/-0.030)</sup>	80 <sup>(+0/-0.030)</sup>	80 <sup>(+0/-0.030)</sup>
LL (without brake)	112.3	138.3	154.8	130.2	153.2
LL (with brake)	152.8	178	187.8	161.3	184.3
LS	27	32	32	30	30
LR	30	35	35	35	35
LE	3	3	3	3	3
LG	8	8	8	8	8
LW	20	25	25	20	20
RH	11	15.5	15.5	13	13
WK	5	6	6	5	5
W	5	6	6	5	5
T	5	6	6	5	5
TP	M4 Depth 15	M6 Depth 20	M6 Depth 20	M5 Depth 15	M5 Depth 15



- 1) Dimensions are in millimeters. Actual measured values are in metric units.
- 2) Dimensions of the servo motor may be revised without prior notice.
- 3) The boxes (□) in the model names represent shaft end/brake or the number of oil seal.
- 4) Please refer to Chapter 1 for the boxes (△) in the model names (which represents encoder type).

**Motor Frame Size: 100 mm ~ 130 mm Models (Units: mm)**

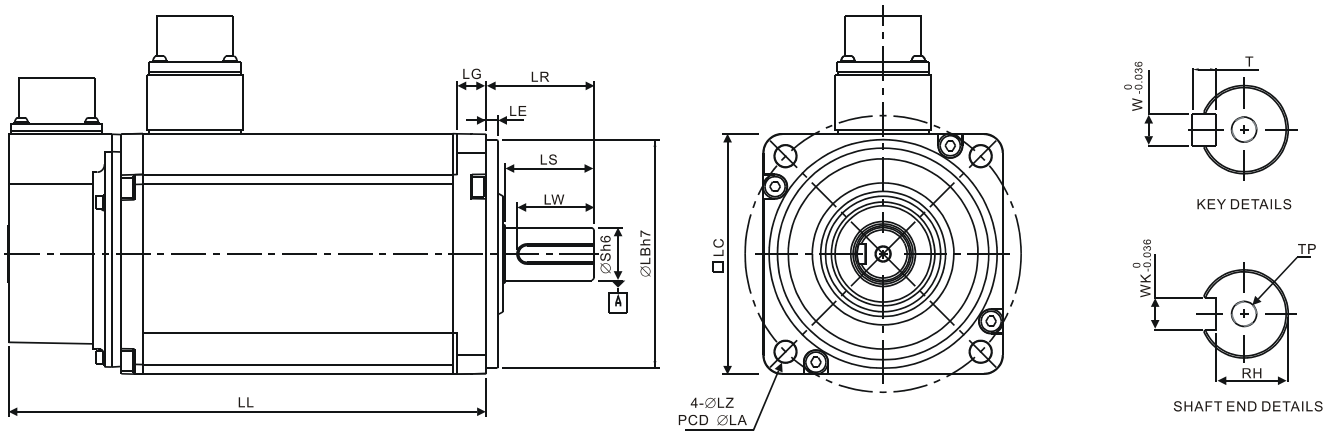

Model	C△1010□S	C△1020□S	C△1330□4	E△1305□S	E△1310□S	E△1315□S	E△1320□S
LC	100	100	130	130	130	130	130
LZ	9	9	9	9	9	9	9
LA	115	115	145	145	145	145	145
S	22 <sup>+0</sup> <sub>-0.013</sub>	22 <sup>+0</sup> <sub>-0.013</sub>	24 <sup>+0</sup> <sub>-0.013</sub>	22 <sup>+0</sup> <sub>-0.013</sub>	22 <sup>+0</sup> <sub>-0.013</sub>	22 <sup>+0</sup> <sub>-0.013</sub>	22 <sup>+0</sup> <sub>-0.013</sub>
LB	95 <sup>+0</sup> <sub>-0.035</sub>	95 <sup>+0</sup> <sub>-0.035</sub>	110 <sup>+0</sup> <sub>-0.035</sub>	110 <sup>+0</sup> <sub>-0.035</sub>	110 <sup>+0</sup> <sub>-0.035</sub>	110 <sup>+0</sup> <sub>-0.035</sub>	110 <sup>+0</sup> <sub>-0.035</sub>
LL (without brake)	153.3	199.0	187.5	147.5	147.5	167.5	187.5
LL (with brake)	192.5	226.0	216.0	183.5	183.5	202.0	216.0
LS	37	37	47	47	47	47	47
LR	45	45	55	55	55	55	55
LE	5	5	6	6	6	6	6
LG	12	12	11.5	11.5	11.5	11.5	11.5
LW	32	32	36	36	36	36	36
RH	18	18	20	18	18	18	18
WK	8	8	8	8	8	8	8
W	8	8	8	8	8	8	8
T	7	7	7	7	7	7	7
TP	M6 Depth 20	M6 Depth 20	M6 Depth 20	M6 Depth 20	M6 Depth 20	M6 Depth 20	M6 Depth 20



- 1) Dimensions are in millimeters. Actual measured values are in metric units.
- 2) Dimensions of the servo motor may be revised without prior notice.
- 3) The boxes (□) in the model names represent shaft end/brake or the number of oil seal.
- 4) Please refer to Chapter 1 for the boxes (△) in the model names (which represents encoder type).



**Motor Frame Size: 100 mm ~ 130 mm Models (Units: mm)**

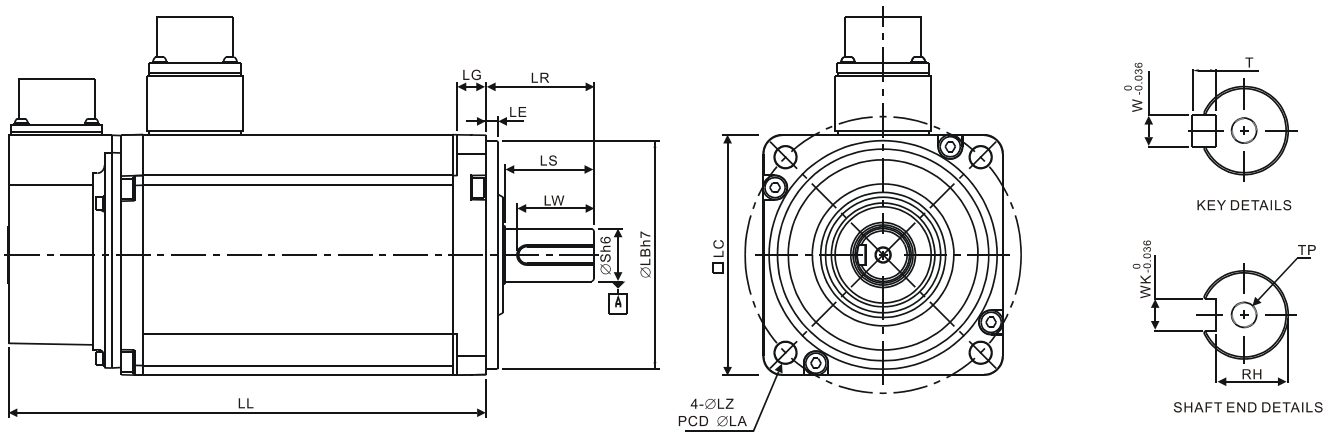

Model	F△1305□S	F△1308□S	F△1313□S	F△1318□S	G△1303□S	G△1306□S	G△1309□S
LC	130	130	130	130	130	130	130
LZ	9	9	9	9	9	9	9
LA	145	145	145	145	145	145	145
S	22 <sup>(+0/-0.013)</sup>	22 <sup>(+0/-0.013)</sup>	22 <sup>(+0/-0.013)</sup>	22 <sup>(+0/-0.013)</sup>	22 <sup>(+0/-0.013)</sup>	22 <sup>(+0/-0.013)</sup>	22 <sup>(+0/-0.013)</sup>
LB	110 <sup>(+0/-0.035)</sup>	110 <sup>(+0/-0.035)</sup>	110 <sup>(+0/-0.035)</sup>	110 <sup>(+0/-0.035)</sup>	110 <sup>(+0/-0.035)</sup>	110 <sup>(+0/-0.035)</sup>	110 <sup>(+0/-0.035)</sup>
LL (without brake)	139.5	152.5	187.5	202.0	147.5	147.5	163.5
LL (with brake)	168.0	181.0	216.0	230.7	183.5	183.5	198
LS	47	47	47	47	47	47	47
LR	55	55	55	55	55	55	55
LE	6	6	6	6	6	6	6
LG	11.5	11.5	11.5	11.5	11.5	11.5	11.5
LW	36	36	36	36	36	36	36
RH	18	18	18	18	18	18	18
WK	8	8	8	8	8	8	8
W	8	8	8	8	8	8	8
T	7	7	7	7	7	7	7
TP	M6 Depth 20	M6 Depth 20	M6 Depth 20	M6 Depth 20	M6 Depth 20	M6 Depth 20	M6 Depth 20



- 1) Dimensions are in millimeters. Actual measured values are in metric units.
- 2) Dimensions of the servo motor may be revised without prior notice.
- 3) The boxes (□) in the model names represent shaft end/brake or the number of oil seal.
- 4) Please refer to Chapter 1 for the boxes (△) in the model names (which represents encoder type).

### Motor Frame Size: 180 mm and above Models (Units: mm)

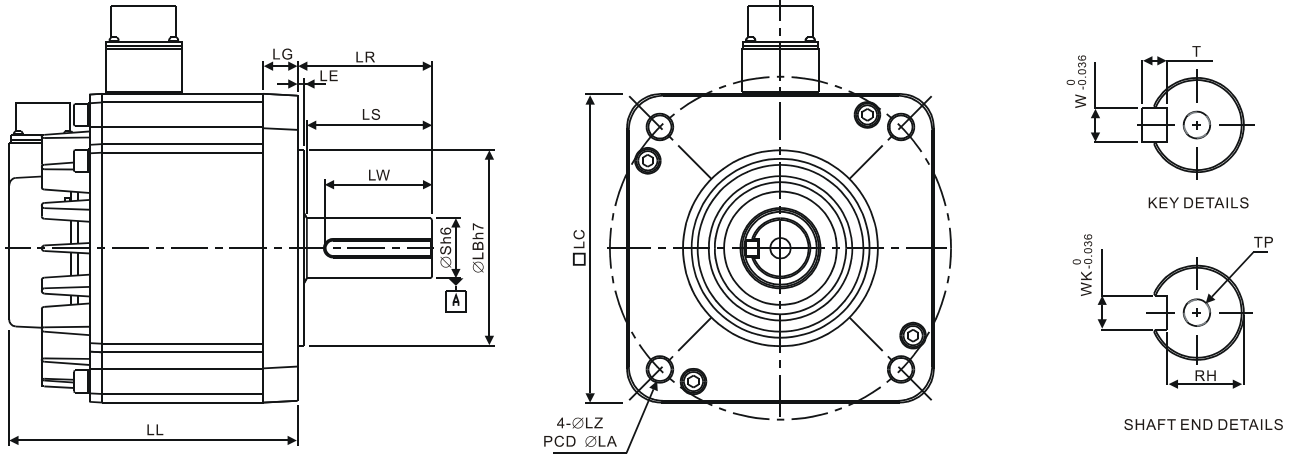

Model	E $\Delta$ 1820□S	E $\Delta$ 1830□S	E $\Delta$ 1835□S	F $\Delta$ 1830□S
LC	180	180	180	180
LZ	13.5	13.5	13.5	13.5
LA	200	200	200	200
S	35 <sup>+0</sup> <sub>-0.016</sub>	35 <sup>+0</sup> <sub>-0.016</sub>	35 <sup>+0</sup> <sub>-0.016</sub>	35 <sup>+0</sup> <sub>-0.016</sub>
LB	114.3 <sup>+0</sup> <sub>-0.035</sub>	114.3 <sup>+0</sup> <sub>-0.035</sub>	114.3 <sup>+0</sup> <sub>-0.035</sub>	114.3 <sup>+0</sup> <sub>-0.035</sub>
LL (without brake)	169.0	202.1	202.1	202.1
LL (with brake)	203.1	235.3	235.3	235.3
LS	73	73	73	73
LR	79	79	79	79
LE	4	4	4	4
LG	20	20	20	20
LW	63	63	63	63
RH	30	30	30	30
WK	10	10	10	10
W	10	10	10	10
T	8	8	8	8
TP	M12 Depth 25	M12 Depth 25	M12 Depth 25	M12 Depth 25



- 1) Dimensions are in millimeters. Actual measured values are in metric units.
- 2) Dimensions of the servo motor may be revised without prior notice.
- 3) The boxes (□) in the model names represent shaft end/brake or the number of oil seal.
- 4) Please refer to Chapter 1 for the boxes (Δ) in the model names (which represents encoder type).

### Motor Frame Size: 180 mm Models (Units: mm)

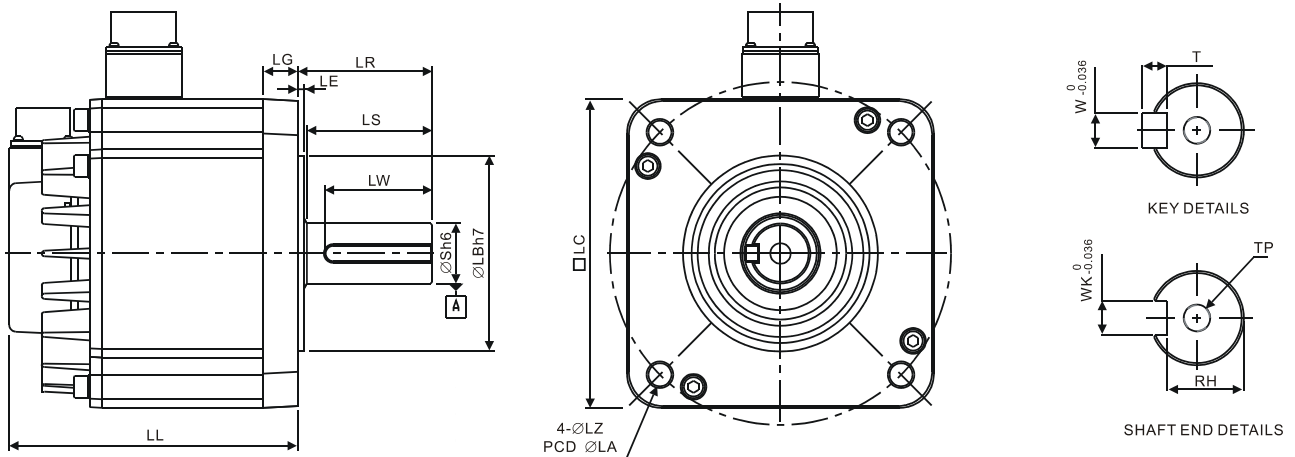

Model	F△1845□S	F△1855□3	F△1875□3
LC	180	180	180
LZ	13.5	13.5	13.5
LA	200	200	200
S	$35^{+0}_{-0.016}$	$42^{+0}_{-0.016}$	$42^{+0}_{-0.016}$
LB	$114.3^{+0}_{-0.035}$	$114.3^{+0}_{-0.035}$	$114.3^{+0}_{-0.035}$
LL (without brake)	235.3	279.7	342.0
LL (with brake)	279.3	311.7	376.1
LS	73	108.5	108.5
LR	79	113	113
LE	4	4	4
LG	20	20	20
LW	63	90	90
RH	30	37	37
WK	10	12	12
W	10	12	12
T	8	8	8
TP	M12 Depth25	M16 Depth32	M16 Depth32



- 1) Dimensions are in millimeters. Actual measured values are in metric units.
- 2) Dimensions of the servo motor may be revised without prior notice.
- 3) The boxes (□) in the model names represent shaft end/brake or the number of oil seal.
- 4) Please refer to Chapter 1 for the boxes (△) in the model names (which represents encoder type).

### Motor Frame Size: 220 mm and above Models (Units: mm)

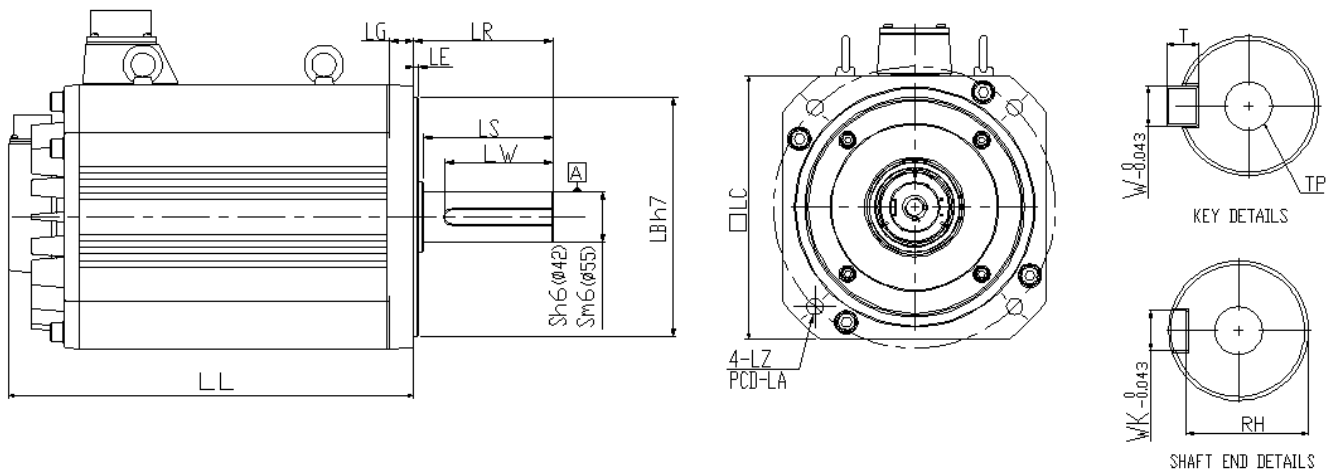

Model	F1221B□3	F1221F□S
LC	220	220
LZ	13.5	13.5
LA	235	235
S	$42^{+0}_{-0.016}$	$55^{+0.003}_{+0.011}$
LB	$200^{+0}_{-0.046}$	$200^{+0}_{-0.046}$
LL (without brake)	371.4	453.4
LL (with brake)	434.4	513.4
LS	108	108
LR	116	116
LE	4	4
LG	20	20
LW	90	90
RH	37	49
WK	12	16
W	12	16
T	8	10
TP	M16 Depth 32	M20 Depth 40



- 1) Dimensions are in millimeters. Actual measured values are in metric units.
- 2) Dimensions of the servo motor may be revised without prior notice.
- 3) The boxes (□) in the model names represent shaft end/brake or the number of oil seal.
- 4) Please refer to Chapter 1 for the boxes (Δ) in the model names (which represents encoder type).

## 11.6.2 400 V Series

### Motor Frame Size: 80 mm and below Models (Units: mm)

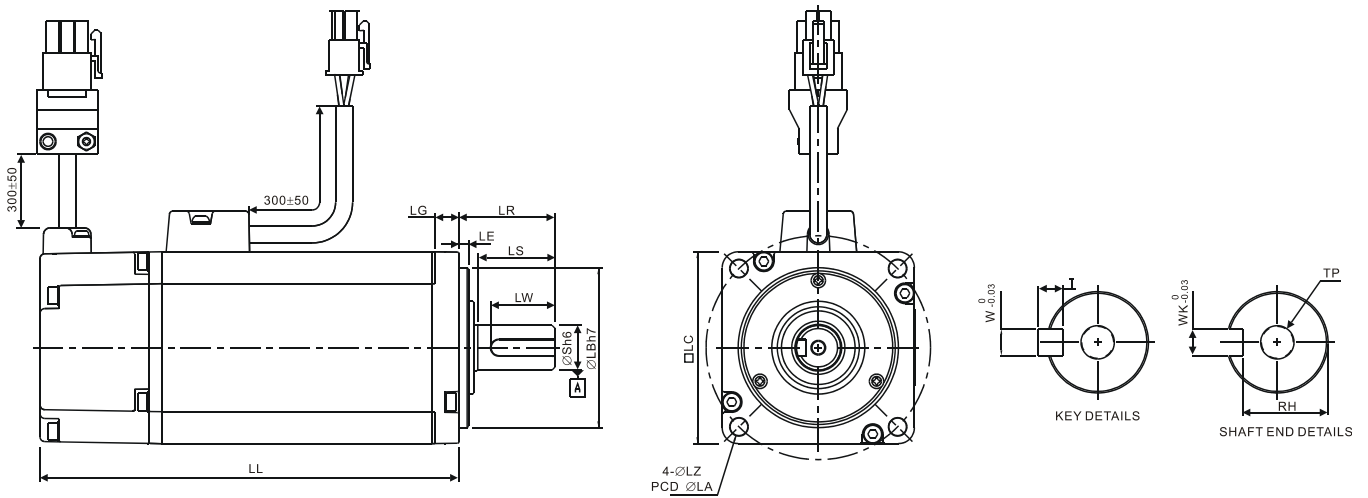

Model	J△0604□S	J△0807□S	J△0907□S	J△0910□S
LC	60	80	86	86
LZ	5.5	6.6	6.6	6.6
LA	70	90	100	100
S	14 <sup>+0</sup> <sub>-0.011</sub>	19 <sup>+0</sup> <sub>-0.013</sub>	16 <sup>+0</sup> <sub>-0.011</sub>	16 <sup>+0</sup> <sub>-0.011</sub>
LB	50 <sup>+0</sup> <sub>-0.025</sub>	70 <sup>+0</sup> <sub>-0.030</sub>	80 <sup>+0</sup> <sub>-0.030</sub>	80 <sup>+0</sup> <sub>-0.030</sub>
LL (without brake)	130.7	138.3	130.2	153.2
LL (with brake)	166.8	178.0	161.3	184.3
LS	27	32	30	30
LR	30	35	35	35
LE	3	3	3	3
LG	7.5	8	8	8
LW	20	25	20	20
RH	11	15.5	13	13
WK	5	6	5	5
W	5	6	5	5
T	5	6	5	5
TP	M4 Depth 15	M6 Depth 20	M5 Depth 15	M5 Depth 15



- 1) Dimensions are in millimeters. Actual measured values are in metric units.
- 2) Dimensions of the servo motor may be revised without prior notice.
- 3) The boxes (□) in the model names represent shaft end/brake or the number of oil seal.
- 4) Please refer to Chapter 1 for the boxes (△) in the model names (which represents encoder type).

## Motor Frame Size: 100 mm Models (Units: mm)

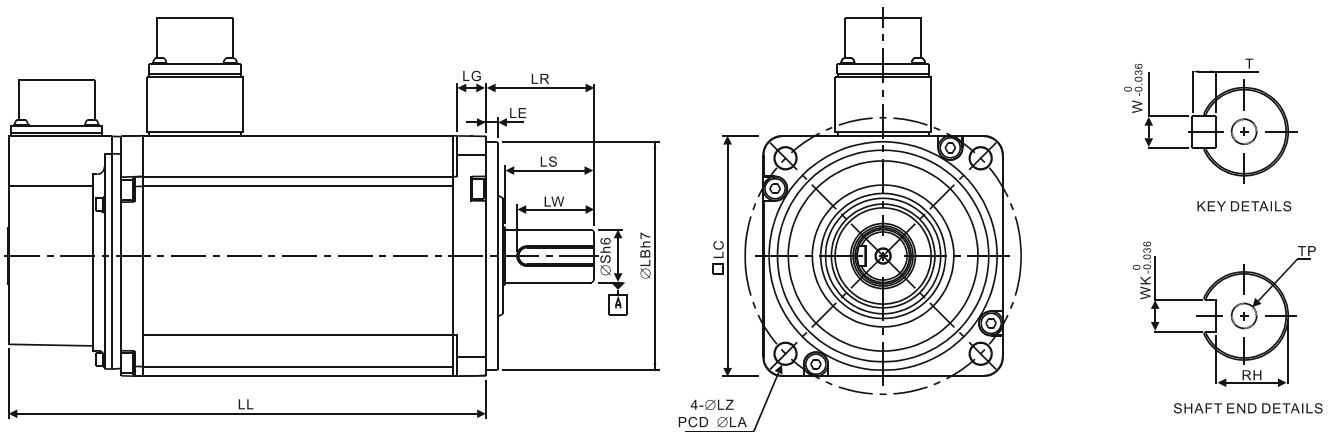

Model	J $\Delta$ 1010□S	J $\Delta$ 1020□S
LC	100	130
LZ	9	9
LA	115	115
S	22 $^{+0}_{-0.013}$	22 $^{+0}_{-0.013}$
LB	95 $^{+0}_{-0.035}$	95 $^{+0}_{-0.035}$
LL (without brake)	153.3	199.0
LL (with brake)	192.5	226.0
LS	37	37
LR	45	45
LE	5	5
LG	12	12
LW	32	32
RH	18	18
WK	8	8
W	8	8
T	7	7
TP	M6 Depth 20	M6 Depth 20



- 1) Dimensions are in millimeters. Actual measured values are in metric units.
- 2) Dimensions of the servo motor may be revised without prior notice.
- 3) The boxes (□) in the model names represent shaft end/brake or the number of oil seal.
- 4) Please refer to Chapter 1 for the boxes (Δ) in the model names (which represents encoder type).

### Motor Frame Size: 130 mm Models (Units: mm)

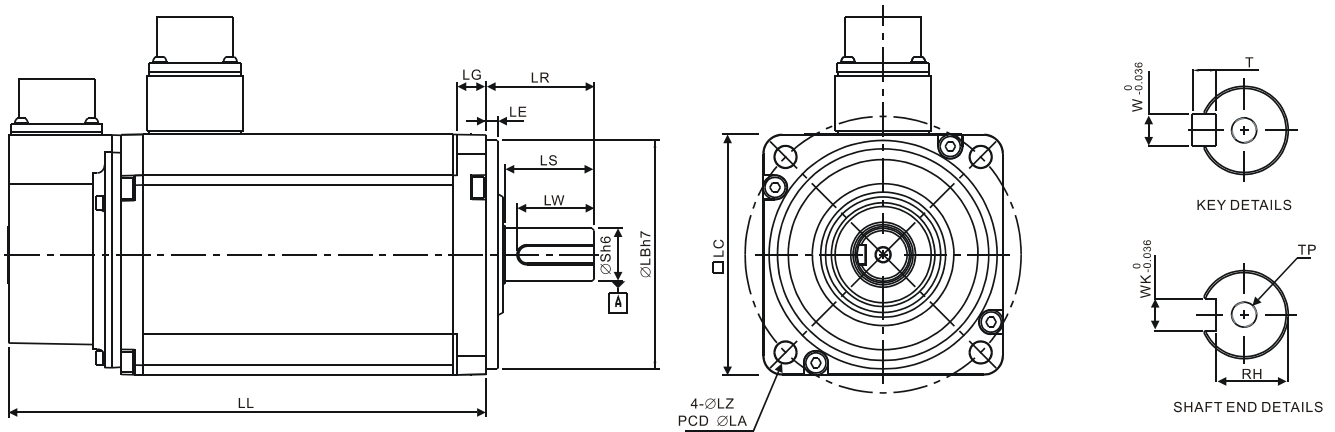

Model	J△1330□4	K△1305□S	K△1310□S	K△1315□S	K△1320□S
LC	130	130	130	130	130
LZ	9	9	9	9	9
LA	145	145	145	145	145
S	24 <sup>(+0/-0.013)</sup>	22 <sup>(+0/-0.013)</sup>	22 <sup>(+0/-0.013)</sup>	22 <sup>(+0/-0.013)</sup>	22 <sup>(+0/-0.013)</sup>
LB	110 <sup>(+0/-0.035)</sup>	110 <sup>(+0/-0.035)</sup>	110 <sup>(+0/-0.035)</sup>	110 <sup>(+0/-0.035)</sup>	110 <sup>(+0/-0.035)</sup>
LL (without brake)	187.5	139.5	147.5	167.5	187.5
LL (with brake)	216.0	168.0	183.5	202.0	216.0
LS	47	47	47	47	47
LR	55	55	55	55	55
LE	6	6	6	6	6
LG	11.5	11.5	11.5	11.5	11.5
LW	36	36	36	36	36
RH	20	18	18	18	18
WK	8	8	8	8	8
W	8	8	8	8	8
T	7	7	7	7	7
TP	M6 Depth 20	M6 Depth 20	M6 Depth 20	M6 Depth 20	M6 Depth 20



- 1) Dimensions are in millimeters. Actual measured values are in metric units.
- 2) Dimensions of the servo motor may be revised without prior notice.
- 3) The boxes (□) in the model names represent shaft end/brake or the number of oil seal.
- 4) Please refer to Chapter 1 for the boxes (△) in the model names (which represents encoder type).

## Motor Frame Size: 130 mm Models (Units: mm)

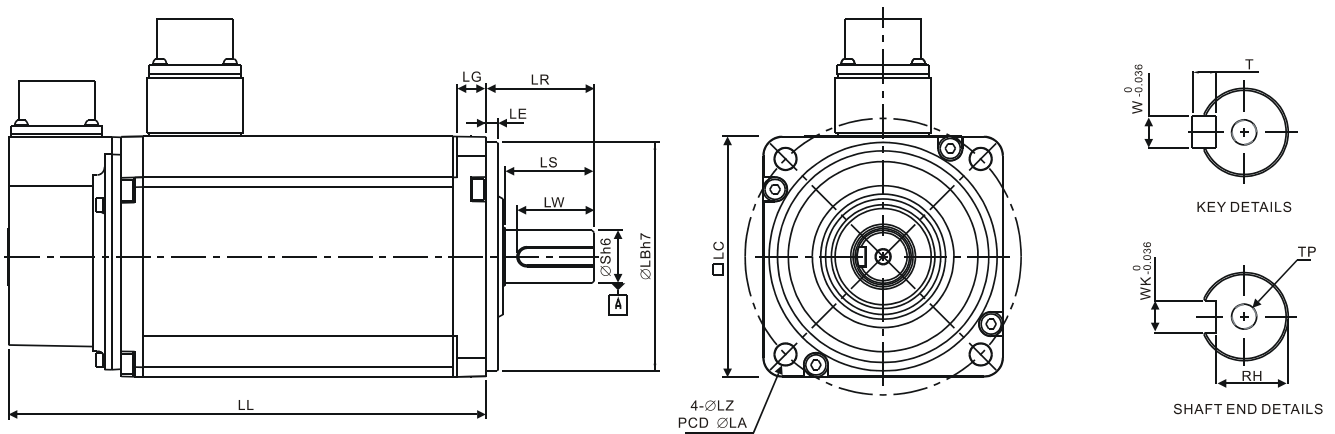

Model	L△1305□S	L△1313□S	L△1308□S	M△1309□S
LC	130	130	130	130
LZ	9	9	9	9
LA	145	145	145	145
S	22 <sup>(+0/-0.013)</sup>	22 <sup>(+0/-0.013)</sup>	22 <sup>(+0/-0.013)</sup>	22 <sup>(+0/-0.013)</sup>
LB	110 <sup>(+0/-0.035)</sup>	110 <sup>(+0/-0.035)</sup>	110 <sup>(+0/-0.035)</sup>	110 <sup>(+0/-0.035)</sup>
LL (without brake)	147.5	194.5	163.5	163.5
LL (with brake)	168.0	223.0	181.0	198.0
LS	47	47	47	47
LR	55	55	55	55
LE	6	6	6	6
LG	11.5	11.5	11.5	11.5
LW	36	36	36	36
RH	18	18	18	18
WK	8	8	8	8
W	8	8	8	8
T	7	7	7	7
TP	M8 Depth 25	M6 Depth 20	M6 Depth 20	M6 Depth 20



- 1) Dimensions are in millimeters. Actual measured values are in metric units.
- 2) Dimensions of the servo motor may be revised without prior notice.
- 3) The boxes (□) in the model names represent shaft end/brake or the number of oil seal.
- 4) Please refer to Chapter 1 for the boxes (△) in the model names (which represents encoder type).



### Motor Frame Size: 180 mm and above Models (Units: mm)

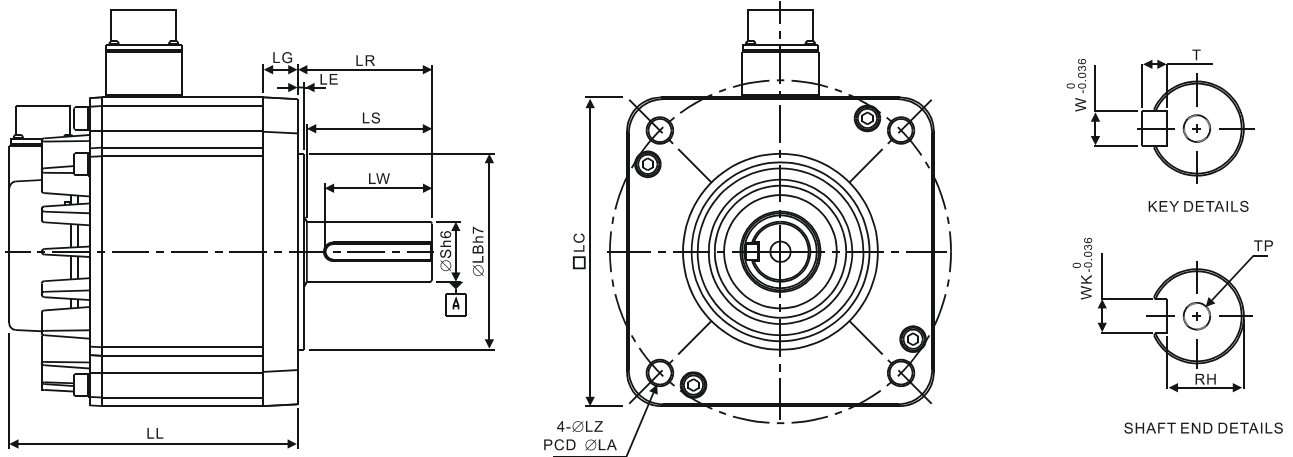

Model	L $\Delta$ 1830 $\square$ S	L $\Delta$ 1845 $\square$ S	L $\Delta$ 1855 $\square$ S	L $\Delta$ 1875 $\square$ S	K $\Delta$ 1820 $\square$ S
LC	180	180	180	180	180
LZ	13.5	13.5	13.5	13.5	13.5
LA	200	200	200	200	200
S	35 $^{+0}_{-0.016}$	35 $^{+0}_{-0.016}$	42 $^{+0}_{-0.016}$	42 $^{+0}_{-0.016}$	35 $^{+0}_{-0.016}$
LB	114.3 $^{+0}_{-0.035}$	114.3 $^{+0}_{-0.035}$	114.3 $^{+0}_{-0.035}$	114.3 $^{+0}_{-0.035}$	114.3 $^{+0}_{-0.035}$
LL (without brake)	202.1	235.3	279.7	342.0	169.0
LL (with brake)	235.3	279.3	311.7	376.1	203.1
LS	73	73	108.5	108.5	73
LR	79	79	113	113	79
LE	4	4	4	4	4
LG	20	20	20	20	20
LW	63	63	90	90	63
RH	30	30	37	37	30
WK	10	10	12	12	10
W	10	10	12	12	10
T	8	8	8	8	8
TP	M12 Depth 25	M12 Depth 25	M16 Depth 32	M16 Depth 32	M12 Depth 25



- 1) Dimensions are in millimeters. Actual measured values are in metric units.
- 2) Dimensions of the servo motor may be revised without prior notice.
- 3) The boxes ( $\square$ ) in the model names represent shaft end/brake or the number.
- 4) Please refer to Chapter 1 for the boxes ( $\Delta$ ) in the model names (which represents encoder type).

# Chapter 12 Absolute System

---

## Introduction

Delta's absolute system includes an ASDA-A2 series servo drive, an ECMA series servo motor with an absolute encoder and a backup battery box for an absolute encoder. An ECMA series servo motor with an absolute encoder has an encoder which is able to rotate and tell the servo motor the actual position when the power is turned on. An absolute encoder in an ECMA series servo motor will constantly record the actual positions by its built-in coordinate system at any time. So the real position of the servo motor will be measured and recorded even if the motor shaft rotates after the power is turned off.

An ECMA series servo motor with an absolute encoder is essential and must be connected with an ASDA-A2 series servo drive for a Delta's absolute system. When an ECMA series servo motor with an incremental encoder is connected to an ASDA-A2 series servo drive, if the users enable the servo parameters for absolute system, a fault code, AL069 will be shown on the drive's LCD display to alert that an error occurs. When AL069 is displayed, please examine if the connected servo motor is a servo motor with an absolute encoder. While using absolute motor, as soon as it applies to the power, the motor speed cannot lower than 250rpm. When operating in battery mode, make sure the maximum speed does not exceed 200rpm. The model name of a servo motor with an absolute encoder is shown as below

ECMA-□A□□□□□□  
└─ A: Servo Motor with Absolute Encoder

One servo drive uses one single battery box. Two servo drives can share a dual battery box. We recommend the users to choose Delta's backup battery boxes and Delta's encoder connection cables for Delta's absolute systems for wiring and connection. Please perform the installation in order as specified in the quick start and user manual when connecting to an absolute system. Regarding the descriptions and specifications of battery boxes and corresponding accessories, please refer to the contents in the following sections.

## 12.1 Backup Battery Boxes

### 12.1.1 Specifications

#### Precautions

Please thoroughly understand and observe the following safety precautions. Failure to observe these precautions may void warranty! In order to prevent damage and danger, please use batteries in accordance with the specified specification.



- Do not use the product in a potentially explosive environment. Install the product in a clean and dry location free from corrosive and inflammable gases or liquids.
- Do not place the battery dispersedly to prevent short circuiting and accidents.
- Do not short circuit the positive pole and the negative pole of the batteries or install batteries in reverse polarity.
- To prevent electric energy loss and lifetime reduction, it is recommended to use new batteries only.



- Do not store batteries within an ambient temperature above +100°C. Failure to observe this precaution may cause fire or explosion.
- The batteries are non-rechargeable. Do not charge the batteries or explosion may result.
- Do not directly solder the battery surface.

#### Battery Specifications

Items	Li/SOCI2 Cylindrical Battery
Type	ER14505
Delta Model Number	ASD-CLBT0100
International Standard Size	AA
Nominal Voltage	3.6 V
Nominal Capacity	2700 mAh
Maximum Continuous Operating Current	100 mA
Maximum Pulse Current	200 mA
Dimensions (D x H)	14.5 x 50.5 mm
Weight	Approx. 19 g
Operating Temperature	-40 ~ +85°C

## Battery Life

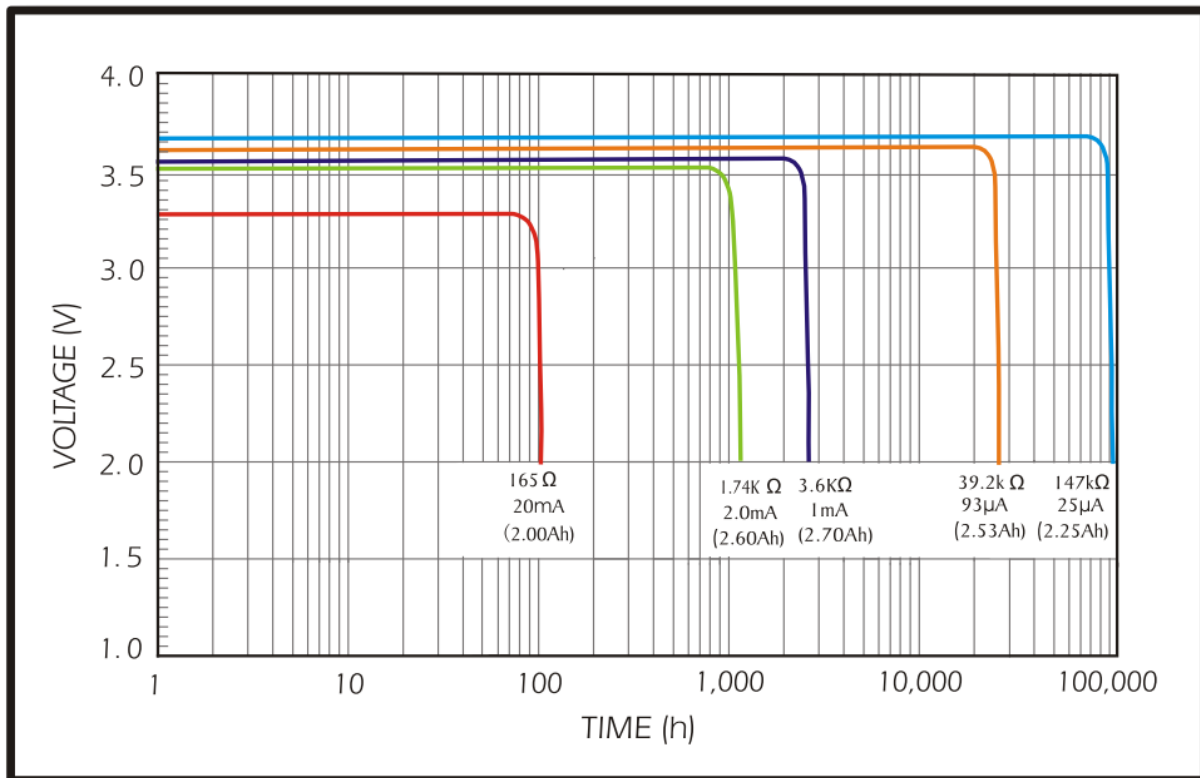

Above figure comes from EVE Energy Co. ER14505 Discharge Characteristics

- (1) The above figure illustrates the discharge current curve generated by constant current test. According to the testing result shown on the graph above, when the power consumption of an absolute encoder is 65μA or lower, if the voltage of the battery keeps 3V or higher, the expected battery life is about 21900hr, approximately 2.5 years <sup>(Note)</sup>. Therefore, the lowest voltage level of battery for an absolute encoder is set to 3.1V.
- (2) The battery life expectancy is about 5 years and is able to provide 3.6V or higher voltage under normal temperature and humidity conditions.



### NOTE

The battery life was measured when one single battery box is connecting to one servo drive and one servo motor.

### 12.1.2 Battery Box Dimensions

Single Battery Box

Delta Model Number: ASD-MDBT0100

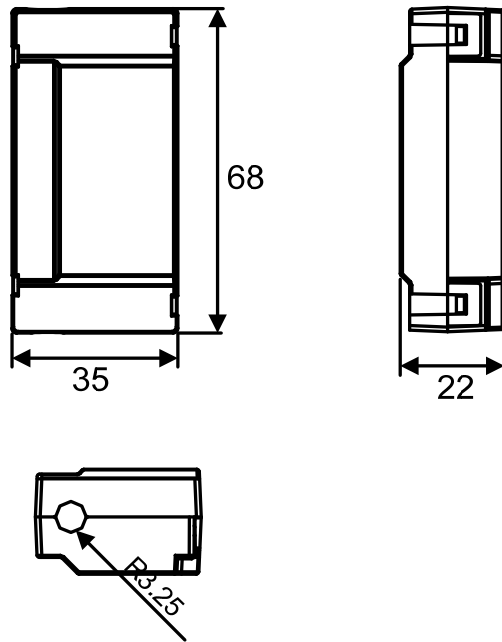

Weight
44 g

Units: mm

Dual Battery Box

Delta Model Number: ASD-MDBT0200

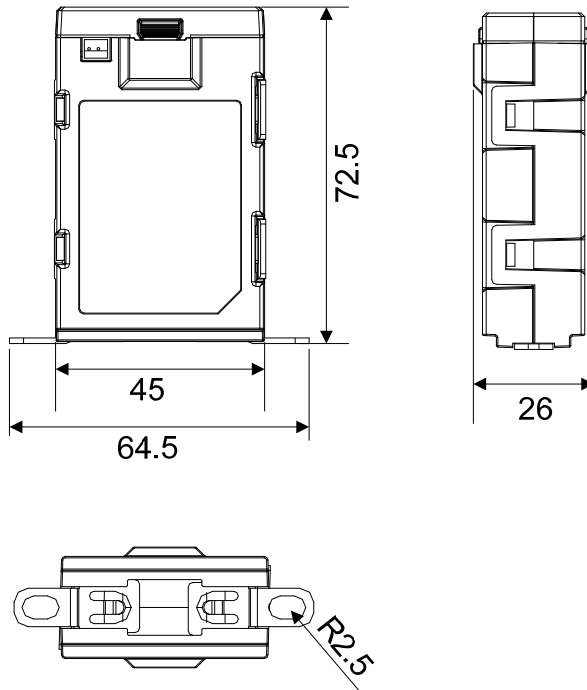

Weight
80 g

Units: mm

### 12.1.3 Connection Cables for Absolute Encoder

#### A. Quick Connector

Delta part number: **ASD-A2EB0003, ASD-A2EB0005**

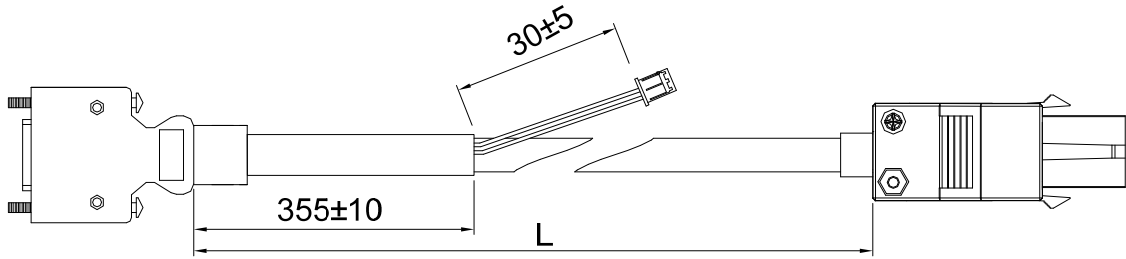

Title	Model Name	L	
		mm	inch
1	ASD-A2EB0003	3000 ± 100	118 ± 4
2	ASD-A2EB0005	5000 ± 100	197 ± 4

#### Connection method:

Please conduct the wiring according to the following instructions. Wrong wiring might cause battery explosion.

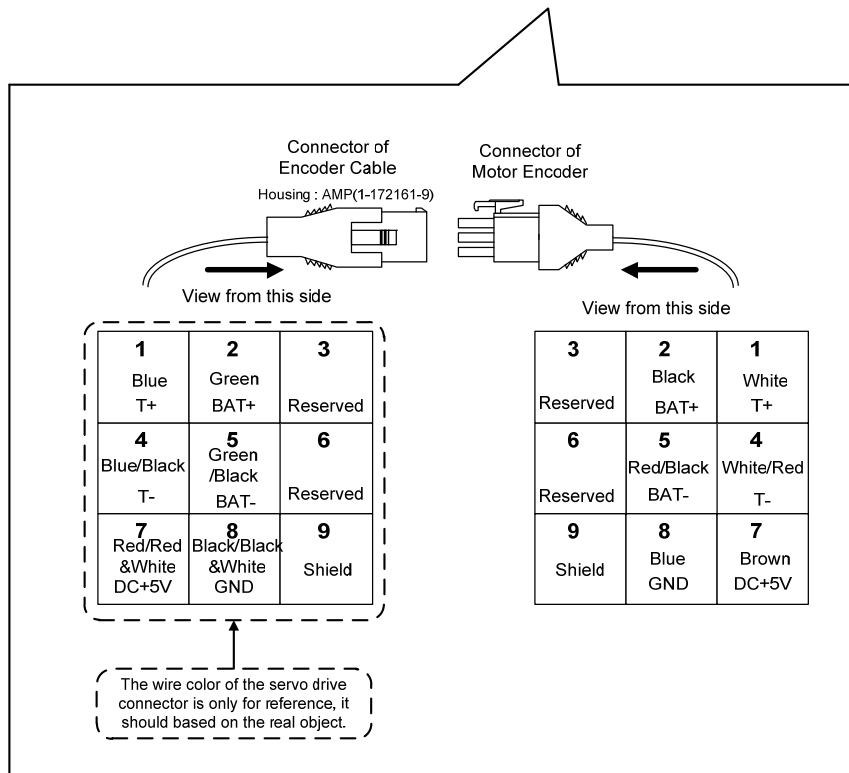
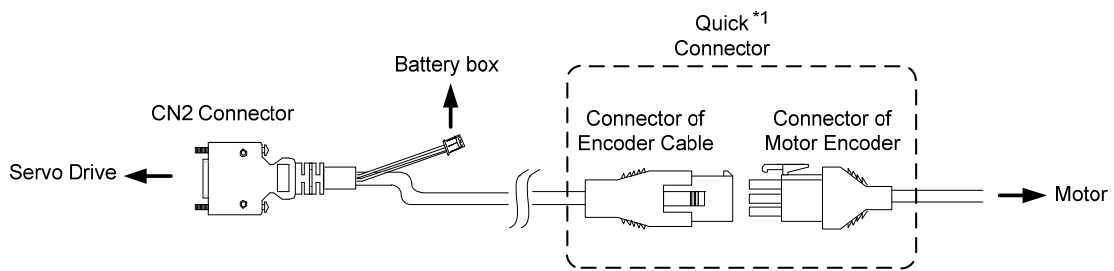

**B. Military Connector**

Delta part number: **ASD-A2EB1003, ASD-A2EB1005**

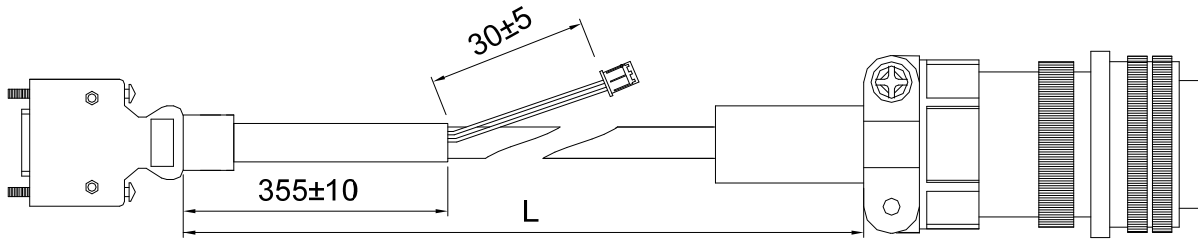

Title	Model Name	L	
		mm	inch
1	ASD-A2EB1003	3000 ± 100	118 ± 4
2	ASD-A2EB1005	5000 ± 100	197 ± 4

**Connection method:**

Please conduct the wiring according to the following instructions. Wrong wiring might cause battery explosion.

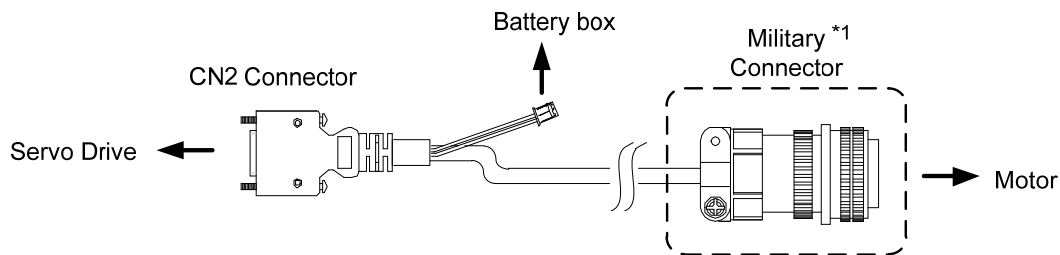

**3106A-20-29S  
Military Connector**

Pin No.	Terminal	Color
A	T+	Blue
B	T-	Black
C	BAT+	Green
D	BAT-	Green/Black
S	DC+5V	Red/Red & white
R	GND	Black/Black & white
L	BRAID SHIELD	-

### 12.1.4 Battery Box Cords

#### Battery Box Cord AW

Delta Part Number: 3864573700

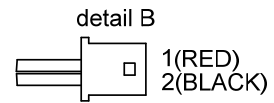
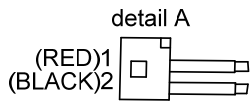
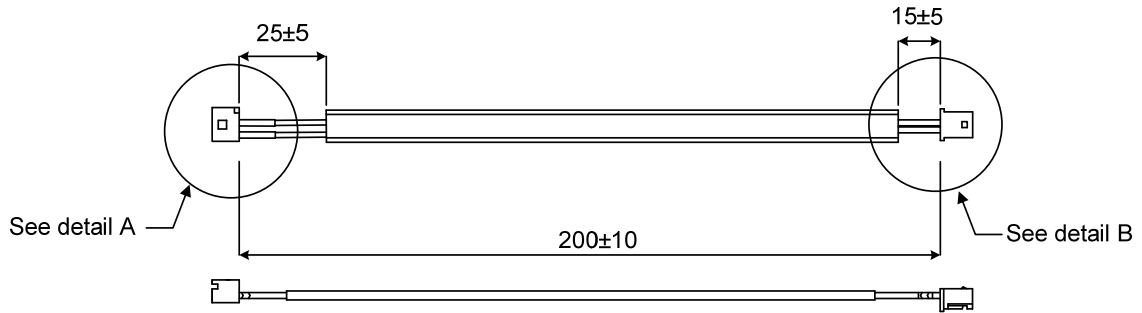

#### Battery Box Cord IW

Delta Part Number: 3864811900

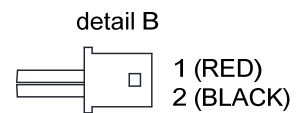
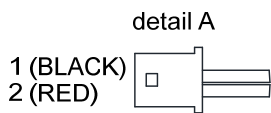
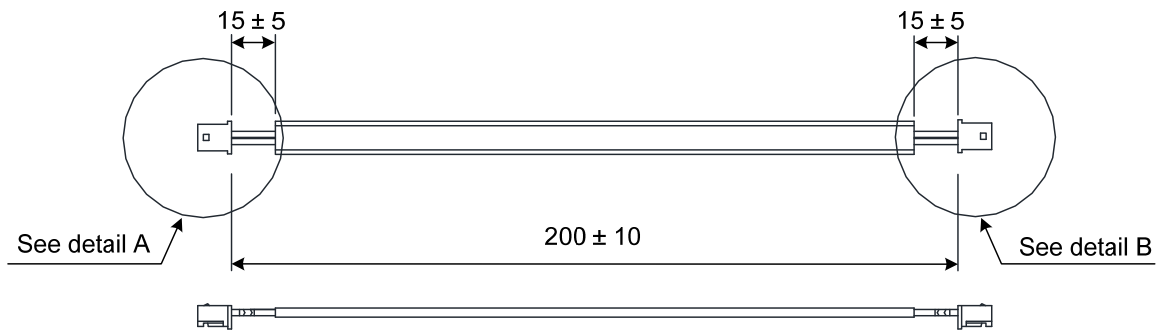



## 12.2 Installation

### 12.2.1 Connection Examples

#### Single Battery Box

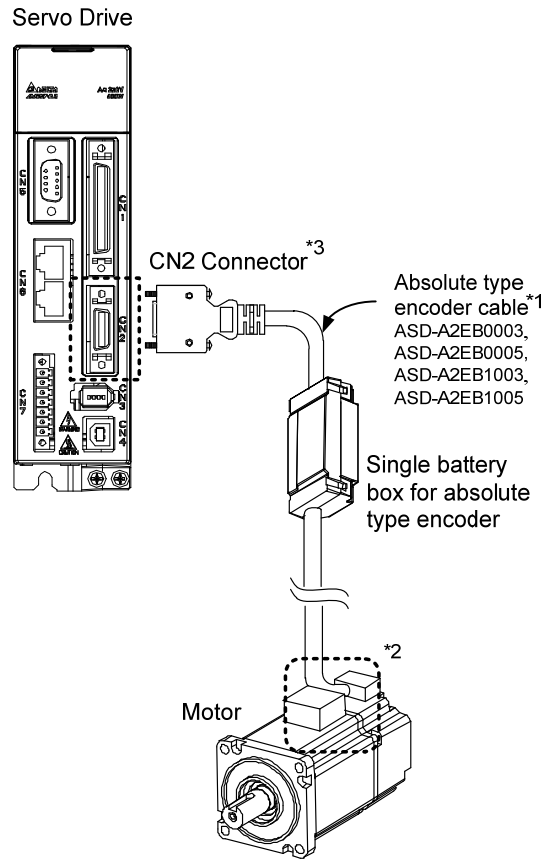

**NOTE** This is the wiring diagram for connecting to a single battery box. The scale of the objects does not match the dimensions as shown in the drawing above. For different models of AC servo drives and motors, the connection cables may differ.

1\* and 2\* Please refer to section 12.1.3.

3\* Definition of CN2 connector

**Please conduct the wiring according to the following instructions. Wrong wiring might cause battery explosion.**

CN2 Connector			Motor Connector	
Pin No	Terminal Symbol	Function and Description	Military Connector	Quick Connector
5	T+	Serial communication signal input/output (+)	A	1
4	T-	Serial communication signal input/output (-)	B	4
7	BAT+	Battery 3.6V	C	2
9	BAT-	Battery ground	D	5
14, 16	+5V	Power+5V	S	7
13, 15	GND	Power ground	R	8
-	Shield	Shield	L	9

Single Battery Box (Connect to CN8)

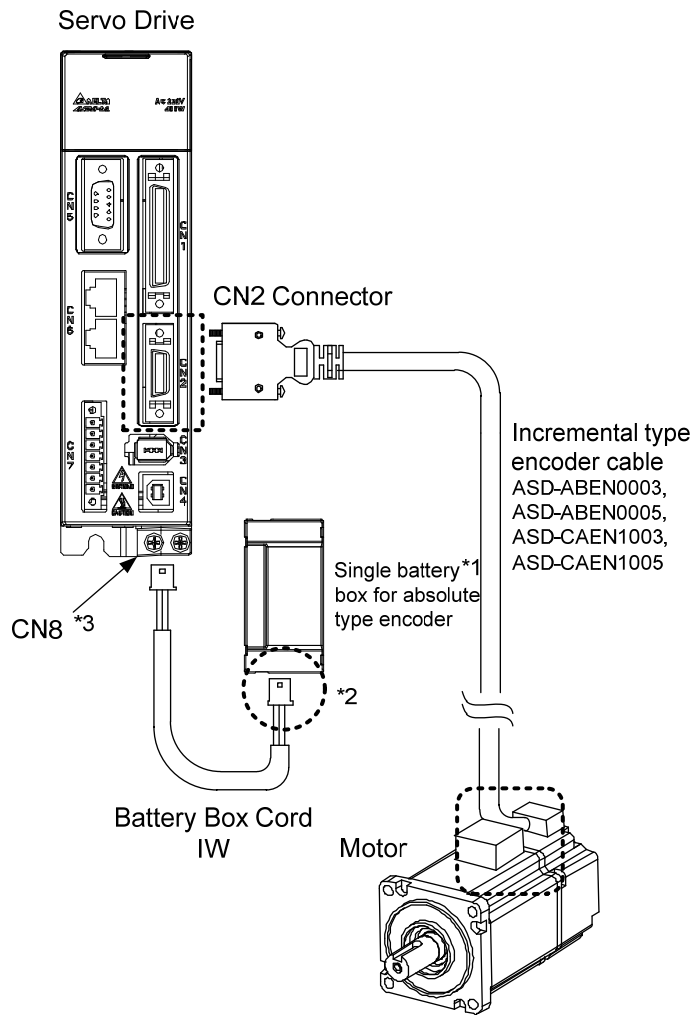

**NOTE** This is the wiring diagram for connecting to a single battery box. The scale of the objects does not match the dimensions as shown in the drawing above. For different models of AC servo drives and motors, the connection cables may differ.

1\* Make sure the battery box is firmly fixed with this connection method.

2\* Connect to power base on single battery box, see the descriptions below:

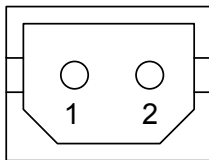

Pin No	Terminal Symbol	Connector Cable
1	BAT+	Red
2	BAT-	Black

3\* Definition of CN8 Connector:

**Please conduct the wiring according to the following instructions. Wrong wiring might cause battery explosion.**

Pin No	Terminal Symbol
1	BAT+
2	BAT-

Dual Battery Box (Connect to CN2)

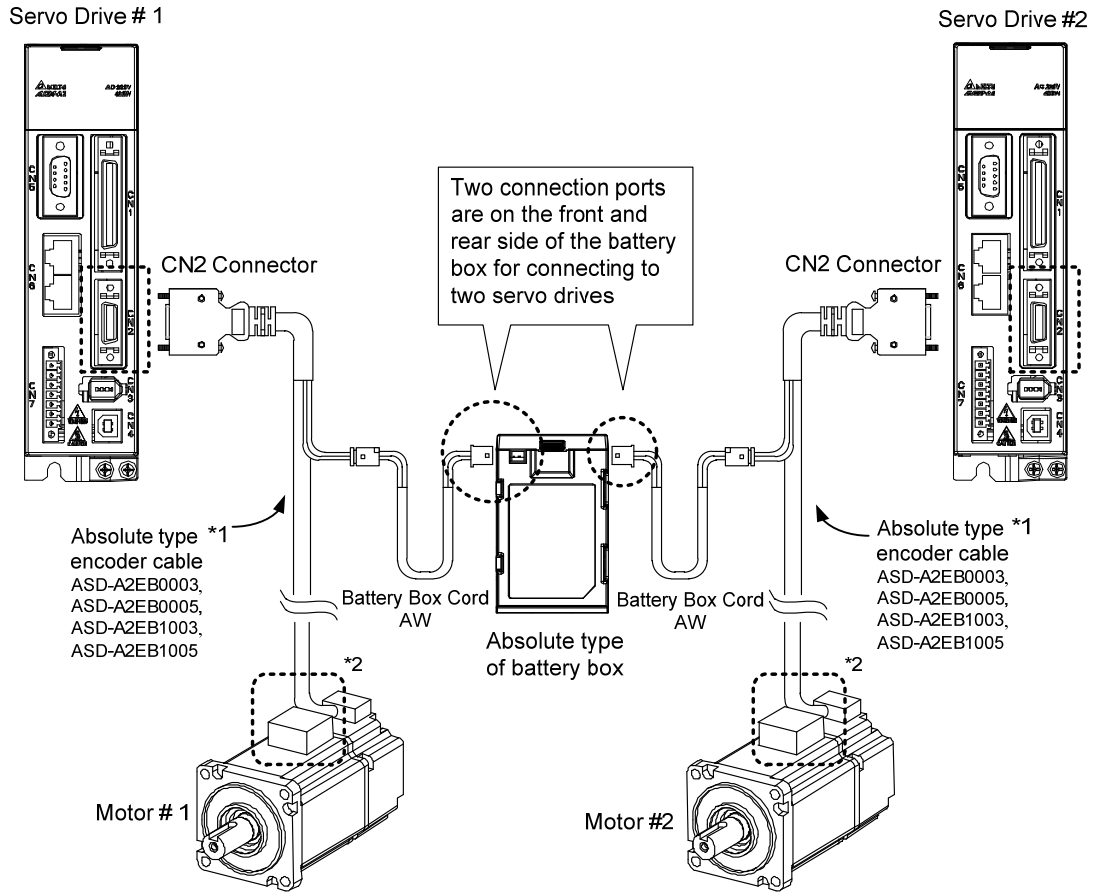

**NOTE**

This is the wiring diagram for connecting to a single battery box. The scale of the objects does not match the dimensions as shown in the drawing above. For different models of AC servo drives and motors, the connection cables may differ.

1\* and 2\* Please refer to section 12.1.3.

3\* Definition of CN2 connector

**Please conduct the wiring according to the following instructions. Wrong wiring might cause battery explosion.**

Pin No	CN2 Connector		Motor Connector	
	Terminal Symbol	Function and Description	Military Connector	Quick Connector
5	T+	Serial communication signal input/output (+)	A	1
4	T-	Serial communication signal input/output (-)	B	4
7	BAT+	Battery 3.6V	C	2
9	BAT-	Battery ground	D	5
14, 16	+5V	Power+5V	S	7
13, 15	GND	Power ground	R	8
-	Shield	Shield	L	9

Dual Battery Box (Connect to CN8)

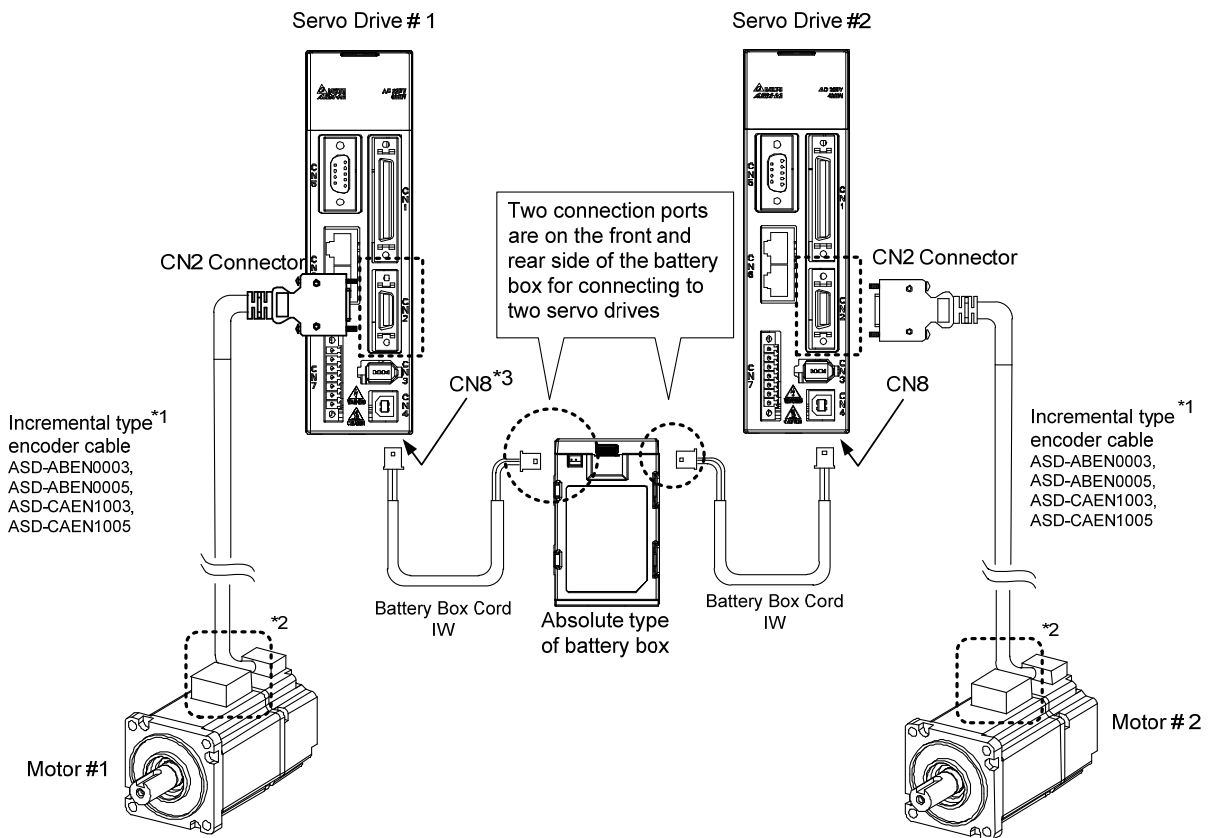

**NOTE**

This is the wiring diagram for connecting to a single battery box. The scale of the objects does not match the dimensions as shown in the drawing above. For different models of AC servo drives and motors, the connection cables may differ.

1\* and 2\* Please refer to section 12.1.3.

3\* Definition of CN8 connector

**Please conduct the wiring according to the following instructions. Wrong wiring might cause battery explosion.**

Pin No	Terminal Symbol
1	BAT+
2	BAT-

### 12.2.2 How to Install a Battery

#### Single Battery Box

Loosen the latches of both sides to open the top cover.

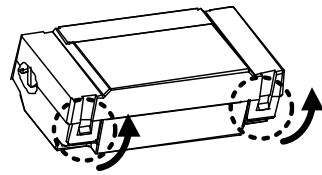

Put on the clip on the cable. Please note that the position of the clip should be very close to the heat shrink tube.

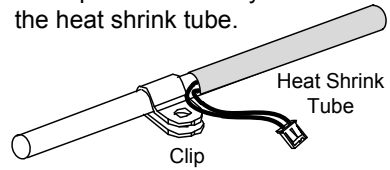

- ① Plug in the connection cable
- ② Turn the screw to tighten it.

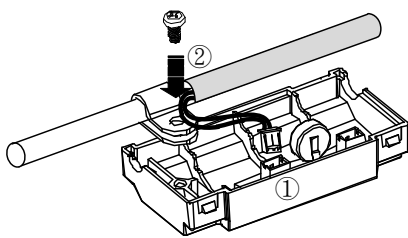

Install a new battery.

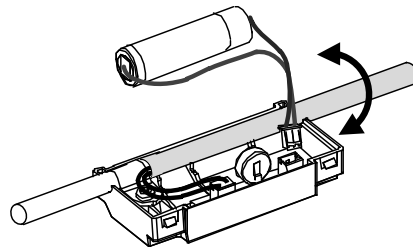

Place the cables into the box and put the cover on the box.

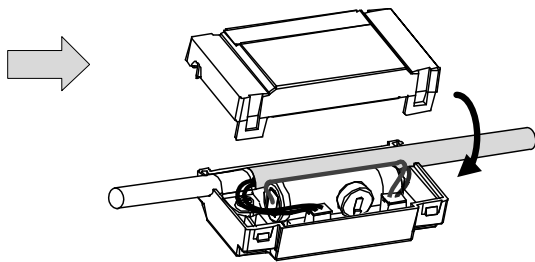

#### Dual Battery Box

Pull the latches located on the bottom side as shown in the figure below.

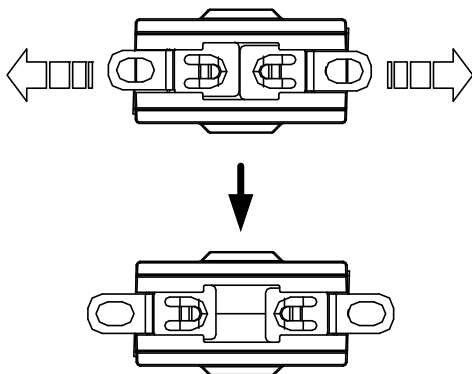

Tighten the mounting screws to secure the battery box.

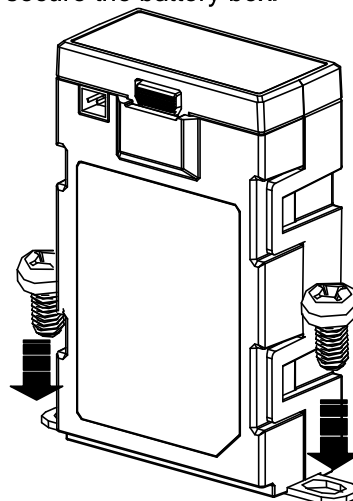

### 12.2.3 How to Replace a Battery

Please replace with a new battery if AL061 occurs, it means the battery is under voltage (Please refer to section 12.7.1 for detailed description). Or when accessing P0-02 for showing the battery power and it displays 31, which means the voltage is under 31V, so as to avoid data lost.

When the voltage is under 2.7V, it might lose the record of motor's position. Please conduct homing after replacing with a new battery. Please refer to 12.7.1 for detailed description

Please replace the battery while the power is applied to the servo drive in order to prevent the absolute position data lose.

#### Single Battery Box

Release the latches located on both sides to open the top cover.

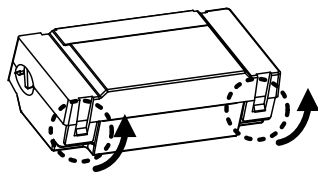

Fully open the top cover

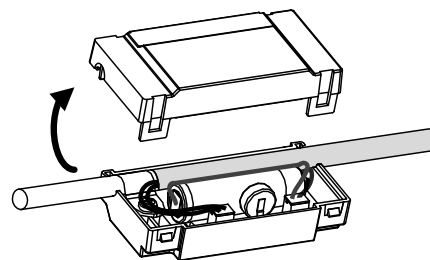

Disconnect the wires and remove the old battery from the box. Then, replace with a new battery. Ensure to connect the connector of new battery to complete the wiring.

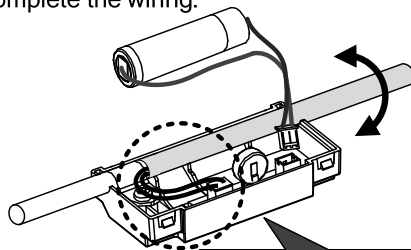

Place the cables into the box and put the cover on the box. Finally, lock the latches to complete the battery replacement.

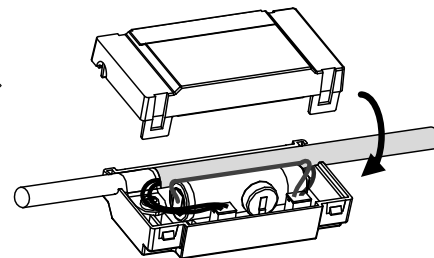

Please replace the battery while power is applied to the drive. Do not remove the power connection, or power interrupt may cause data loss.

### Dual Battery Box

Please replace the battery while power is applied to the drive. Do not remove the power connection, or power interrupt may cause data loss.

Press the latches located on both sides to open the top cover.

Lifting the top cover is able to pull out the batteries.

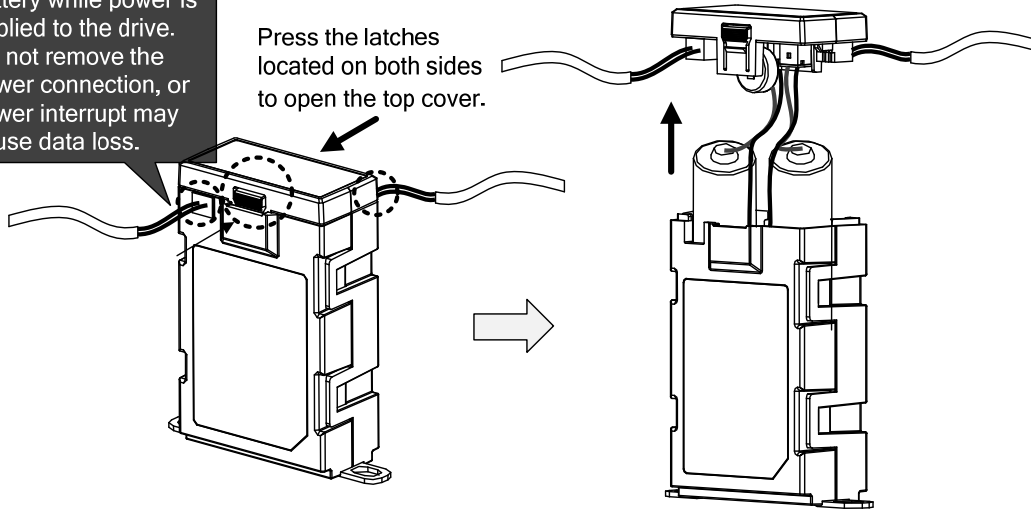

Disconnect the wires and remove the old batteries. Then, replace with new batteries. Ensure to connect the connectors of new batteries to complete the wiring. To prevent the data loss, please replace the batteries in 10 minutes.

Push down the cover until they lock.

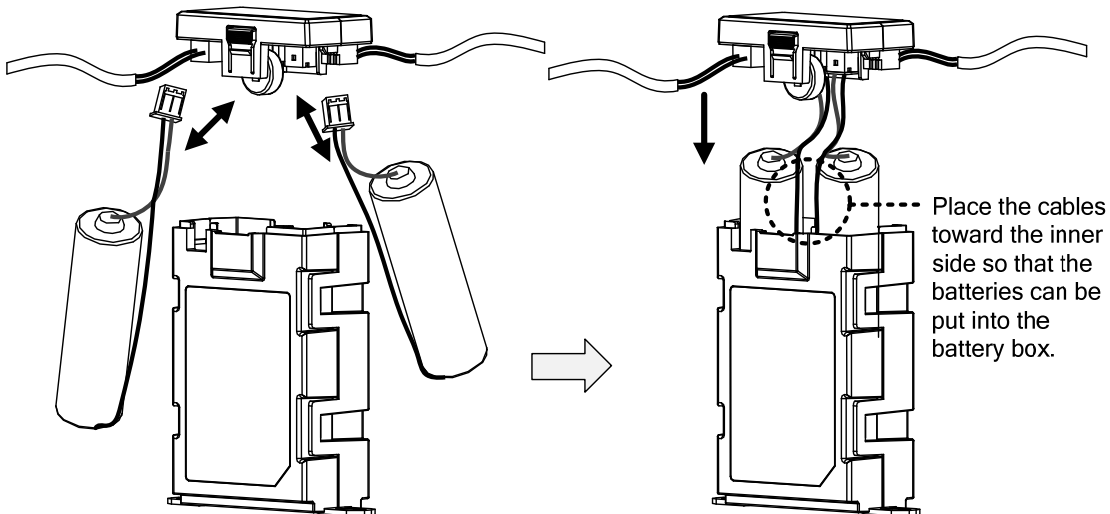

Place the cables toward the inner side so that the batteries can be put into the battery box.

## 12.3 System Initialization Procedure and Operation

### 12.3.1 System Initialization Procedure

When the servo system is power on, the host controller can get the motor coordinate position via communication with RS-485 or DI/O. There are two data in different units can be read, and they are in PULSE and PUU.

At the very first time to operate absolute system, there will be a fault code, AL060 shown when power on because the initialization procedure still not yet be done. The fault will be kept until the initialization procedure is finished. Besides, the AL060 will be displayed when the power from the servo and battery is discontinued that will lead to the coordinate system lost. There is a fault code, AL062 which is used to indicate when the motor position is exceeding the design range where -32768 ~ 32767 for motor turns. But from the view of PUU, the coordinate value must fall into the range -2147483648 ~ 2147483647 to avoid triggering the fault AL289.

For some applications which will rotate motor in one direction, the fault AL062 for checking turns number within -32763~32768 and the fault AL289 for detecting PUU within -2147483648~2147483647 can be turned off by parameter P2-70.

Parameter Settings:

1. The AL060 will be cleared when the coordinate system has been initialized.

PR mode: The absolute coordinate system will be reset after any homing operation under PR mode.

Other modes: Two methods can be used to initialize the coordinated system. One is via digital inputs described in section 12.3.4, and another one is applying parameters in section 12.3.5.

2. For an initialized system when every time the power is turned on, the host controller can read the absolute coordinate data via digital inputs and digital outputs (see section 12.3.6) or parameters with communication (see section 12.2.6). Through the settings of parameter P2-70, the host controller can read the coordinated data in PUU (see section 12.3.3) or in number of turn plus the number of pulse within one turn (see section 12.3.2).



### 12.3.2 Pulse Counting

When the motor is running in clockwise direction, the counting number of turns will be minus where the counter clockwise rotating is plus. The number range for turns is from -32768 to 32767. The fault code, AL062 will appear when exceeding this counting range and it can be cleared by resetting the coordinate system. If parameter P2-70 has been set to ignore the over range alarming, the AL062 is disabled even exceeding the counting range. When the value reaches its largest number, it will rewind. For the counter clockwise counting, the sequence of the number is ...32767, -32768, -32767, -32766 .... and the clockwise will have a sequence like ...-32768, 23767, 32766 ....

In addition, there are 1280000 pulses (0~1279999) in one rotation. Please pay attention on its direction. The communication or digital inputs/digital outputs can be used to read it.

Pulse number for the distance = m (turn) × 1280000 + pulse number within one turn (0~1279999)

The conversion between Pulse and PUU:

When the rotating direction is CCW defined in P1-01.

$$\text{PUU number} = \text{pulse number} \times \frac{(P1-45)}{(P1-44)} + (P6-01)$$

When the rotating direction is CW defined in P1-01.

$$\text{PUU number} = (-1) \times \text{pulse number} \times \frac{(P1-45)}{(P1-44)} + (P6-01)$$

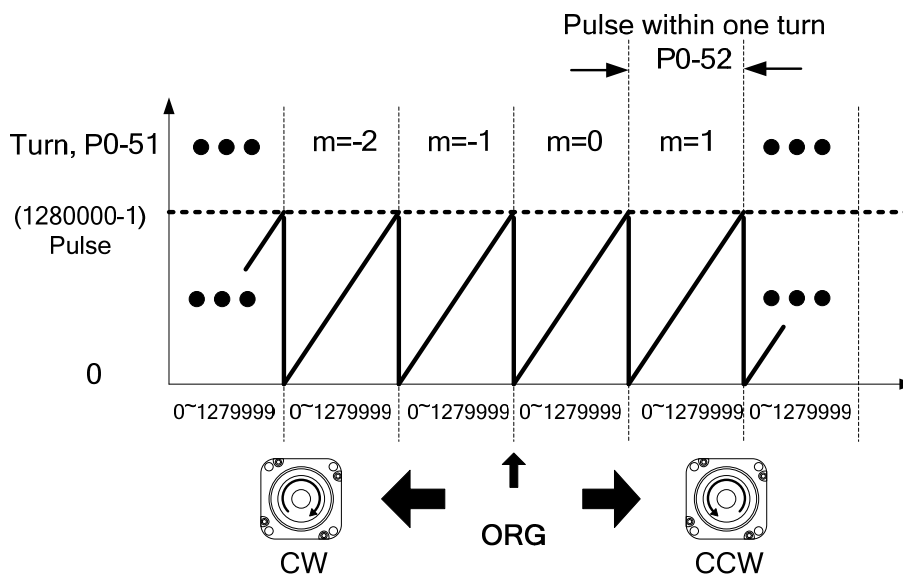

Figure 12.1 Pulse counting in absolute coordinate system

### 12.3.3 PUU Counting

A 32 bits number with sign is used to denote PUU number in an absolute system. The PUU number is increasing when motor is in positive rotating direction and decreasing for a negative running direction. The motor's rotating direction is defined in P1-01 Z setting.

In a word, the encoder feedback number is an easy way to distinguish the motor's rotating direction. Increasing number sequence is for positive direction and decreasing number sequence is for negative direction.

If the motor keeps rotating in one direction, the AL062 will be shown when exceeding the number range -32768 to 32767 for turns, and the AL289 is for PUU out of the range -2147483648 to 22147483647. Both of these fault codes can be cleared by homing.

And the parameter P2-70 can be used to take the range restrictions away in order to avoid occurring AL062 and AL289. When the counting number reaches the maximum number, the PUU pulse number sequence for forward rotation is ... 2147483647, -2147483648, -2147483647... where the number sequence -2147483648, 2147483647, 2147483646... is for reverse rotation. Two examples for evaluating the timing of overflow are as below:

Example 1:

When P1-44=128 and P1-45=10, there are 100000 PUU for motor to rotate one turn.  $2147483647 \div 100000 \approx 21474.8$ . The limit to trigger the fault AL289 is 21474.8 (< 32767).

Example 2:

When P1-44=128 and P1-45=1, there are 10000 PUU for motor to rotate one turn.  $2147483647 \div 10000 \approx 214748.3$ . The limit to trigger the fault AL062 is 32767 (< 214748.3).

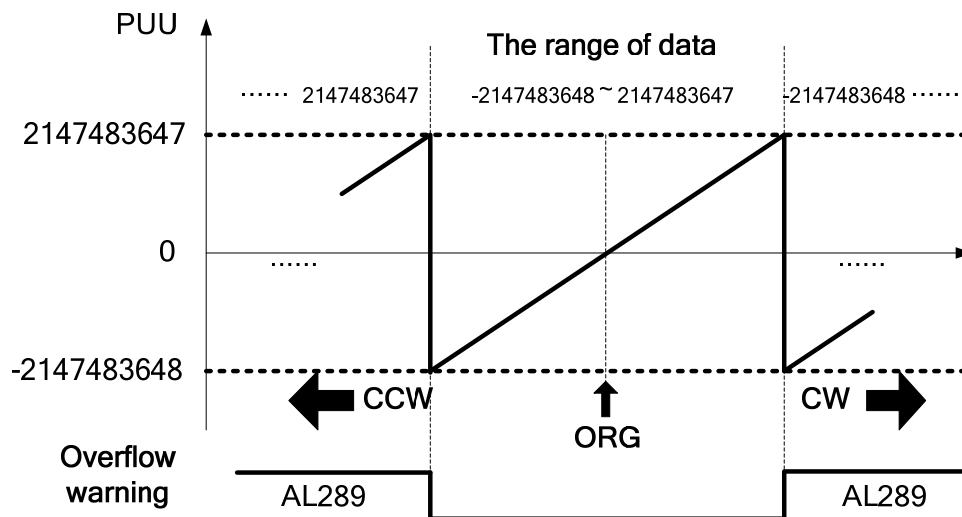

Figure 12.2 PUU counting in absolute coordinate system



#### NOTE

When an absolute system has been initialized, if the parameter P1-01 Z setting, P1-44, and P1-45 be changed, the absolute coordinate system will be destroyed. A homing procedure is necessary at that moment.

### 12.3.4 Use Digital Inputs/Outputs to Initialize an Absolute System

Except PR mode, the digital inputs and outputs can be used for a driver to do homing when other modes are selected. Move the motor to home place, enable digital input, ABSE, then enable digital input, ABSC from OFF to ON, and the system will start to initialization. The pulse number will be set to zero and the number in P6-01 is for PUU to reference. Please refer to Figure 12.3 below for the signal controlling chart.

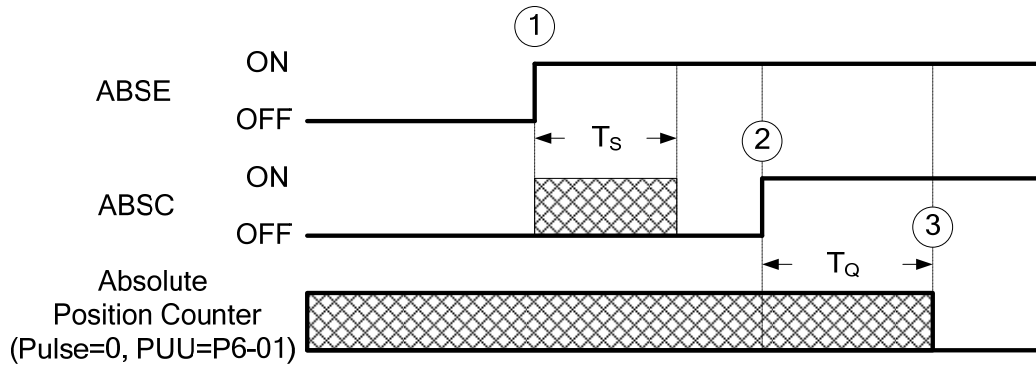

	$T_{S(ms)}$	$T_{Q(ms)}$
Min.	P2-09+2	
Max.	P2-09+10	

Figure 12.3 The controlling chart for initializing an absolute system via digital inputs/outputs

The descriptions for the timing:

1. When the host controller switches ABSE from OFF to ON, a period of time  $T_s$  have to be waited for the next step to process.
2. After waiting time  $T_s$ , the host controller now can enable the ABSC from OFF to ON and hold the signal for  $T_q$  to reset the coordinate system where pulse number will be zero and PUU number is defined in P6-01.

### 12.3.5 Use Parameters to Initialize an Absolute System

When the parameter P2-71 is set to 1(one) via digital keypad or communication, the system starts to initialization. In order to protect from accidentally writing on P2-71 to reset an absolute system, the number 271 should be written to P2-08 to unlock the writing of 1(one) to P2-71. The procedure is P2-08=271 and then P2-71=1. This mode is only for the other modes except PR mode that already has its homing procedure to apply.

### 12.3.6 Use Digital Inputs/Outputs to Read the Absolute Coordinate Data

When Bit 0 is 0 in P2-70, the PUU number can be read by using digital inputs and outputs. The frame is as below.

Bit 79 ~ Bit 64	Bit 63 ~ Bit 32	Bit 31 ~ Bit 16	Bit 15 ~ Bit 0
Check Sum	Encoder PUU -2147483648 - 2147483647	0	Encoder status, P0-50

When Bit 0 is 1 in P2-70, the PULSE number can be read by using digital inputs and outputs. The frame is as below.

Bit 79 ~ Bit 64	Bit 63 ~ Bit 32	Bit 31 ~ Bit 16	Bit 15 ~ Bit 0
Check Sum	Pulse within one turn 0 ~ 1279999 (= 1280000-1)	Encoder turn -32768 ~ +32767	Encoder status, P0-50

Explanation:

Check Sum = ((((((WORD\_0+0xA700) XOR WORD\_1)+0x605A) XOR WORD\_2)+0x30A5) XOR WORD\_3)+0x5A06)

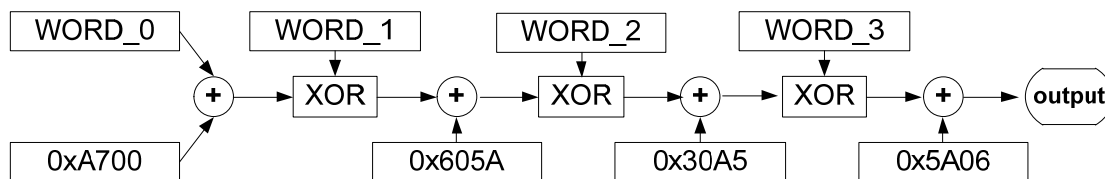

Note:

1. This algorithm has no plus or minus sign.
2. 0xA700, 0x605A, 0x30A5 and 0x5A06 are the constants of hexadecimal.
3. WORD\_0: encoder status (Bit 15~0)  
WORD\_1: encoder turn (Bit 31~16)  
WORD\_2: encoder pulse (Bit 47~32)  
WORD\_3: encoder pulse (Bit 63~48)

The setting in P2-70 with digital inputs/outputs communication can be used to read PULSE number or PUU data with below signal communication sequence.

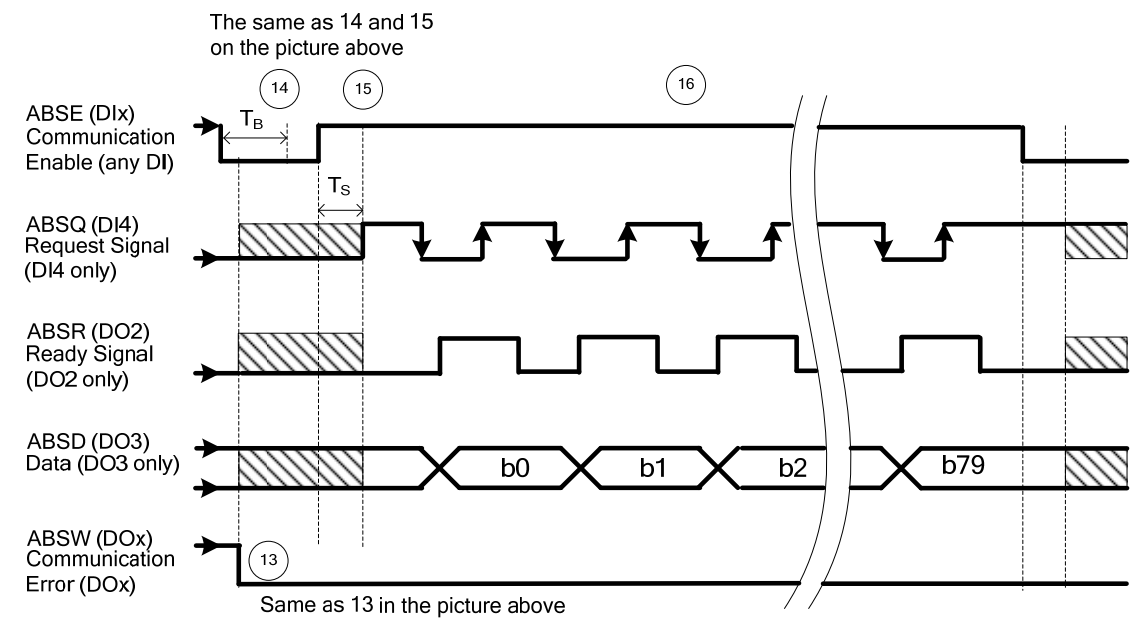
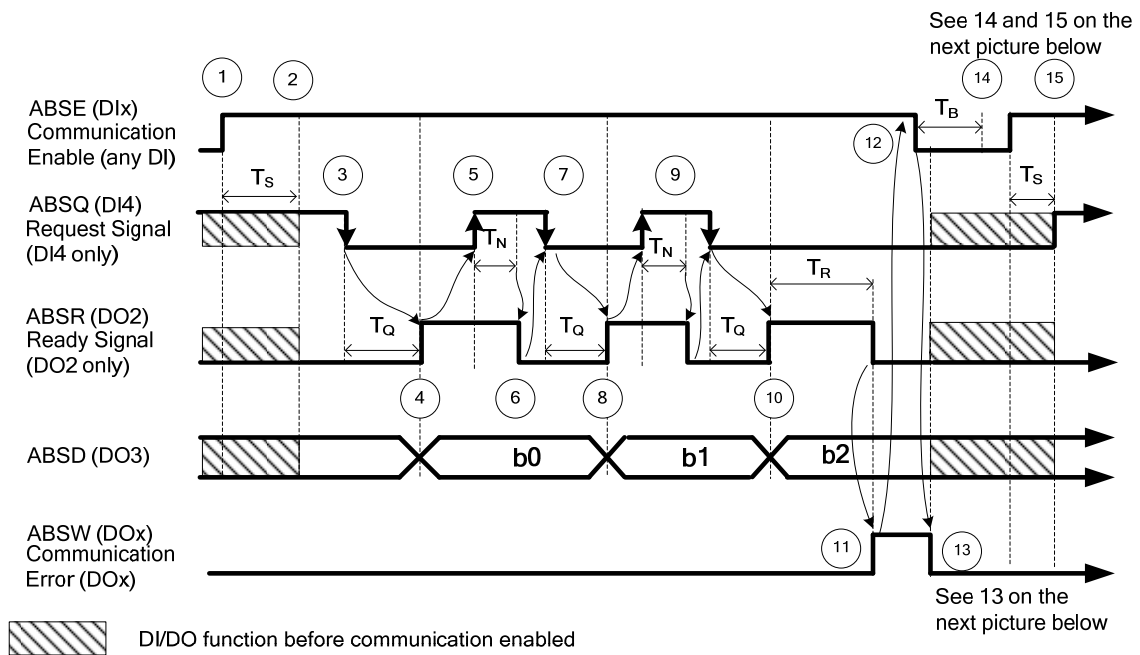

	$T_R(ms)$	$T_S(ms)$	$T_Q(ms)$	$T_N(ms)$	$T_B(ms)$
Min	-	P2-09+2			
Max	200	P2-09+10			

Figure 12.4 Timing of using digital inputs/outputs to read absolute data

The step explanation for the communication:

- ①. At the very beginning of communication, the host controller must enable ABSE and all the communication starts from here.
- ②. A threshold time  $T_s$  for confirming the signal ABSE is necessary. After the signal has been recognized, the DI4, DO2, and DO3 (no matter what their functions are), will be switched to the function of ABSQ, ABSR, and ABSD respectively. At the moment of the communication function enabled, if the signal of ABSQ is in high level, it will keep high level for its original function and also will be high level signal for ABSQ. DI4, DO2, and DO3 are multiple functions pins, please be noted especially at the moment of communication function switching on and off. For the purpose of simplifying the application, the functions of these three digital inputs and outputs could be set to 0 for communication use only.
- ③. When ABSE is at high level and retaining  $T_s$  long, the function of DI4 will be switched to ABSQ. If the host controller switch ABSQ to low after it is defined, the servo drive will recognize that host controller wants to read data from it.
- ④. After confirming time  $T_Q$ , the data for communication is already well prepared on ABSD and the signal ABSR is enabled for signaling the host controller to get data from the servo drive side. If the longest possible waiting time of  $T_Q$  (see Figure 12.4) expired, the host controller still cannot get the signal ABSR from low to high which could be a problem of wiring disconnection.
- ⑤. After the host controller detects that ABSR is high, the data is fetched. The ABSQ will be set to signal high to inform the drive after data read.
- ⑥. After confirming time  $T_N$  for ABSQ kept high, the servo drive will maintain ABSR to low for signaling the host controller to be ready for accessing next bit.
- ⑦. The host will set ABSQ to low when it detects that ABSR is low for requesting the next bit from drive.
- ⑧. The servo drive will repeat the steps 3 to 4 to put its data at ABSD for next bit communication
- ⑨. By repeating steps 5 to 7, the host controller will get the data, bit, and have an acknowledgement to the servo drive.
- ⑩. The third bit data is ready on the servo drive side.
- ⑪. After the data is ready and has been held for time  $T_R$ , the servo drive still does not see the signal ABSQ controlled by the host controller, and then the servo drive will have a communication error flag ABSW raise to terminate the communication procedure.
- ⑫. The host controller will set the ABSE to low for restart the communication cycle after getting the communication error message from the servo drive.
- ⑬. The communication error flag on servo drive side will be reset after detecting a low signal ABSE from the host controller.
- ⑭. A new communication cycle on host controller will be restarted after the buffering time  $T_B$ .
- ⑮. Repeat the step 1 for the host controller to start a new communication cycle.

- ⑩. If there doesn't have any error occurred during communication course for the host controller to finish bit 0 to bit 79 (80 bits data), the functions of DI4, DO2, DO3 will be changed back to their original functions before communication cycle started.

 **NOTE**

If ABSW does not go back to high level signal after the changing of ABSE for signal low to high that is a sign of error occurring, there must be some other errors existing. Please check if the coordinate data still there, the voltage level of battery, or overflowing on the coordinate value.

A new communication cycle can be started only all of these errors been removed.

### 12.3.7 Use Parameter to Read the Absolute Coordinate Data

The servo drive will update its encoder status to P0-50 and encoder position to P0-51 and P0-52 when the parameter P0-49 is set. The Bit 1 of P2-70 is used to select which type of the data will be read, PULSE or PUU. While the servo motor is stalling, it is always maintaining its position with a very tiny forward and backward movement. At the moment the encoder data read, the coordinate data in servo drive side will be reset to the current position of motor if P0-49=2 where it is just read without changing any from the servo motor when P0-49=1. For example of P0-49=2, if the motor is positioning at the place of 20000, it will move around position from 19999 to 20001 normally. The command for reading the encoder data is put when the motor is at the place 20001, and the data 20001 will be read and the coordinate data in servo drive will be revised to 20001. There will avoid the error from the data at encoder side and the data at drive side. The P0-49 will be reset to 0 when all the encoder data put in P0-50 to P0-52 is ready, and it means that the host controller can get the data now. When the status already signals absolute coordinate data lost or overflow of number for turns in P0-50, the values in P0-51 to P0-52 are not correct. A homing or system reset procedure is necessary now.

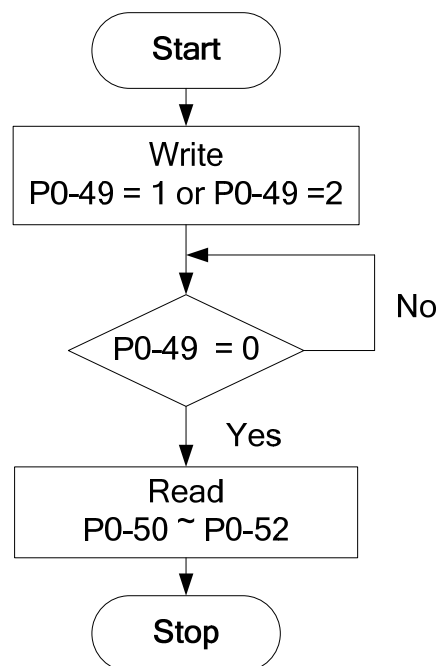



## 12.4 Related Parameters for Absolute System

<b>P2-69●</b>	<b>ABS</b>	<b>Absolute Encoder Setting</b>		<b>Address: 028AH 028BH</b>
	Operational Interface :	Panel / Software	Communication	Related Section: N/A
	Default :	0x0		
	Control Mode :	ALL		
	Unit :	N/A		
	Range :	0x0 ~ 0x1		
	Data Size :	16-bit		
	Format :	Hexadecimal		

Settings : 0: Incremental mode. Servo motor with absolute encoder can be operated as incremental motor.

1: Absolute mode. (This setting is only available for the servo motor with absolute encoder. When an incremental servo motor is connected, if P2-69 is set to 1, AL.069 will occur.)



**NOTE**

This parameter is effective only after the servo drive is re-powered on.

<b>P2-70</b>	<b>MRS</b>	<b>Read Data Format Selection</b>		<b>Address: 028CH 028DH</b>
	Operational Interface :	Panel / Software	Communication	Related Section: N/A
	Default :	0x0		
	Control Mode :	ALL		
	Unit :	N/A		
	Range :	0x00 ~ 0x07		
	Data Size :	16-bit		
	Format :	Hexadecimal		

Settings :

Bit 7	Bit 6	Bit 5	Bit 4	Bit 3	Bit 2	Bit 1	Bit 0
Bit 15	Bit 14	Bit 13	Bit 12	Bit 11	Bit 10	Bit 9	Bit 8

Bit 0: Data unit setting of digital input/output (DI/DO);

1: Pulse, 0: PUU

Bit 1: Communication data unit setting; 1: Pulse, 0: PUU

Bit 2: Overflow warning; 1: No overflow warning, 0: Overflow warning,

AL.289 (PUU), AL.062 (pulse).

Bit 3 ~ Bit 15: Reserved. Must be set to 0.

P2-71 ■	CAP	Absolute Position Homing	Address: 028EH 028FH
Operational Interface :		Panel / Software	Communication
Default :		0x0	
Control Mode :		ALL	
Unit :		N/A	
Range :		0x0 ~ 0x1	
Data Size :		16-bit	
Format :		Hexadecimal	

Settings : When P2-71 is set to 1, the current position will be set as home position. This function is the same as the digital input, ABSC. This function can be enabled only when parameter P2-08 is set to 271.

P0-49 ■	UAP	Renew Encoder Absolute Position	Address: 0062H 0063H
Operational Interface :		Panel / Software	Communication
Default :		0x0	
Control Mode :		ALL	
Unit :		N/A	
Range :		0x00 ~ 0x02	
Data Size :		16-bit	
Format :		Hexadecimal	

Settings : This parameter is used to renew the absolute position data of the encoder.

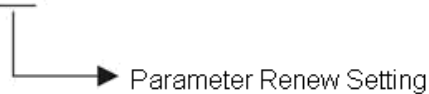

Parameter Renew Setting:

- 1: Renew the encoder data to parameters P0-50~P0-52 only.
- 2: Renew the parameters P0-50~P0-52, and clear the position error as

well. While this setting is activated, the current position of the motor will be reset as the target position of position command (same function as CCLR).

<b>P0-50★</b>	<b>APSTS</b>	<b>Absolute Coordinate System Status</b>	<b>Address: 0064H 0065H</b>
---------------	--------------	--	---------------------------------

Operational Interface :	Panel / Software	Communication	Related Section: N/A
Default :	0x0		
Control Mode :	ALL		
Unit :	N/A		
Range :	0x00 ~ 0x1F		
Data Size :	16-bit		
Format :	Hexadecimal		

Settings :

Bit7	Bit6	Bit5	Bit4	Bit3	Bit2	Bit1	Bit0
Bit15	Bit14	Bit13	Bit12	Bit11	Bit10	Bit9	Bit8

Bit0: Absolute position status

Bit0=0: Normal

Bit0=1: Absolute position is lost

Bit1: Voltage level of battery

Bit0=0: Normal

Bit0=1: Low battery

Bit2: Status of encoder multiturn

Bit0=0: Normal

Bit0=1: Overflow

Bit3: Status of PUU

Bit0=0: Normal

Bit0=1: Overflow

Bit4: Absolute coordinate system status

Bit0=0: Normal

Bit0=1: Absolute coordinate system has not been set

Bit5 ~ Bit15: Reserved. Must be set to 0.

**P0-51★**

<b>APR</b>	<b>Encoder Absolute Position (Multiturn)</b>	<b>Address: 0066H 0067H</b>
Operational: Interface :	Panel / Software      Communication	Related Section: N/A
Default :	0x0	
Control: Mode :	ALL	
Unit :	rev	
Range :	-32768 ~ +32767	
Data Size :	32-bit	
Format :	Decimal	

Settings : While the Bit 1 of P2-70 is set to read the encoder pulse number, this parameter represents the turns of encoder absolute position. While the Bit 1 of P2-70 is set to read the PUU number, this parameter becomes disabled and the setting value of this parameter is 0.

**P0-52★**

<b>APP</b>	<b>Encoder Absolute Position (Pulse number within Singleturn or PUU)</b>	<b>Address: 0068H 0069H</b>
Operational: Interface :	Panel / Software      Communication	Related Section: N/A
Default :	0x0	
Control: Mode :	ALL	
Unit :	Pulse or PUU	
Range :	0~1280000-1 (Pulse Number); -2147483648 ~ 2147483647 (PUU)	
Data Size :	32-bit	
Format :	Decimal	

Settings : While the Bit 1 of P2-70 is set to read the pulse number, this parameter represents the pulse number of encoder absolute position. While the Bit 1 of P2-70 is set to read the PUU number, this parameter represents PUU number of motor absolute position.

<b>P0-02</b>	<b>STS</b>	<b>Drive Status</b>	<b>Address: 0004H 0005H</b>
--------------	------------	---------------------	---------------------------------

Operational Interface :	Panel / Software	Communication	Related Section: 7.2
Default :	00		
Control Mode :	ALL		
Unit :	-		
Range :	00 ~ 127		
Data Size :	16-bit		
Format :	Decimal		

- Settings :
- 00 : Motor feedback pulse number (after the scaling of electronic gear ratio) [PUU]
  - 01 : Input pulse number of pulse command (after the scaling of electronic gear ratio) [PUU]
  - 02 : Deviation between control command pulse and feedback pulse number [PUU]
  - 03 : The number of motor feedback pulse [Encoder unit, 1,280,000 Pulse/rev]
  - 04 : Distance to command terminal (Encoder unit) [Pulse]
  - 05 : Error pulse number (after the scaling of electronic gear ratio) (Encoder unit) [Pulse]
  - 06 : The frequency of pulse command input [Kpps]
  - 07 : Motor speed [r/min]
  - 08 : Speed command input [Volt]
  - 09 : Speed command input [r/min]
  - 10 : Torque command input [Volt]
  - 11 : Torque command input [%]
  - 12 : Average torque [%]
  - 13 : Peak torque [%]
  - 14 : Main circuit voltage (BUS voltage) [Volt]
  - 15 : Load/motor inertia ratio [0.1times]
  - 16 : IGBT temperature

17 : The frequency of resonance suppression

18 : The distance from the current position to Z. The range of the value is between -5000 and +5000;

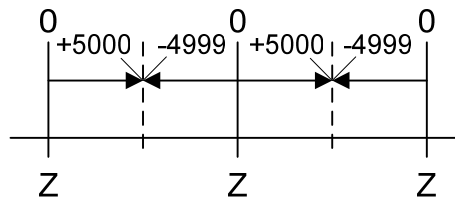

The interval of the two Z-phase pulse command is 10000 Pulse.

19 : Mapping Parameter #1 : P0 - 25

20 : Mapping Parameter #2 : P0 - 26

21 : Mapping Parameter #3 : P0 - 27

22 : Mapping Parameter #4 : P0 - 28

23 : Monitor Variable #1 : P0 - 09

24 : Monitor Variable #2 : P0 - 10

25 : Monitor Variable #3 : P0 - 11

26 : Monitor Variable #4 : P0 - 12

38 : It displays the battery voltage [0.1 Volt]. For example, if it displays 36, it means the battery voltage is 3.6 V.

72 : Analog speed command [0.1 r/min] (This is supported by A2-M/-U/-L.)

## 12.5 Digital Input (DI) Function Definition (for Absolute System)

Setting Value: 0x1D			
DI Name	Function Description of Digital Input (DI)	Trigger Method	Control Mode
ABSE	When DI.ABSE is ON, it is in ABS mode. DI.ABSQ, DI.ABSC, DI.ABSR, DI.ABSD and DI.ABSC are enabled. When DI.ABSE is ON, the function of DI4, DO2, and DO3 will be disabled. Function of DI4 will be ASDQ, DO2 will be ABSR and DO3 will be ABSD.	Level Triggered	ALL

Setting Value: When DI.ABSE is ON, DI4 inputs ABSQ signal, function set by P2-13 is disabled.			
DI Name	Function Description of Digital Input (DI)	Trigger Method	Control Mode
ABSQ is always inputted by DI4	During I/O transmission, Handshaking signal will be sent to the servo drive by the controller. When DI.ABSQ is OFF, it means the controller issues Request ; DI.ABSQ is ON means the controller has already received ABSD signal. When DI.ABSE is ON, this DI is enabled. Please refer to diagram 13.4 for detailed description.	Rising / Falling-edged Triggered	ALL

Setting Value: 0x1F			
DI Name	Function Description of Digital Input (DI)	Trigger Method	Control Mode
ABSC	When DI.ABSC is ON, multi-turn data stored in absolute encoder will be cleared. When DI.ABSE is ON, this function is enabled.	Rising-edge Triggered	ALL

## 12.6 Digital Output (DO) Function Definition (for Absolute System)

**Setting Value: When DI.ABSE is ON, DO2 outputs ABSR signal, function set by P2-19 is disabled.**

DO Name	Function Description of Digital Output (DO)	Trigger Method	Control Mode
ABSR is always outputted by DO2	DO.ABSR is OFF means the Request sent by ABSQ has been received. DO.ABSR is ON means the data that is outputted by ABSD is valid. When DI.ABSE is ON, this DO is enabled. Please refer to diagram 12.4 for detailed description.	Level Triggered	ALL

**Setting Value: When DI.ABSE is ON, DO3 outputs ABSD signal, function set by P2-20 is disabled.**

DO Name	Function Description of Digital Output (DO)	Trigger Method	Control Mode
ABSD is always outputted by DO3	Position data of ABS is outputted. The data is valid when ABSR is ON. When DI.ABSE is ON, this DO is enabled. Please refer to diagram 13.4 for detailed description.	Level Triggered	ALL

**Setting Value : 0x0D**

DO Name	Function Description of Digital Output (DO)	Trigger Method	Control Mode
ABSW	Warning of absolute encoder.	Level Triggered	ALL



## 12.7 Alarms for Absolute System

Display	Alarm Name	Alarm Description
<b>AL028</b>	Encoder voltage error or the internal of the encoder is in error	Charging circuit of the servo drive is not removed and the battery voltage is higher than the specification (>3.8 V) or the encoder signal is in error.
<b>AL029</b>	Gray code error	Absolute position is in error.
<b>AL060</b>	The absolute position is lost	Due to battery under voltage or the failure of power supply, the encoder lost the internal record.
<b>AL061</b>	Encoder under voltage	The voltage of the absolute encoder is lower than the specification
<b>AL062</b>	The multi-turn of absolute encoder overflows	The multi-turn of absolute encoder exceeds the maximum range: -32768 ~ +32767
<b>AL068</b>	Absolute data transmitted via I/O is in error	The sequence is wrong when reading the absolute position via DIO.
<b>AL069</b>	Wrong motor type	Incremental motor is not allowed to activate the absolute function.
<b>AL289</b>	Feedback position counter overflows	Feedback position counter overflows.

## 12.7.1 Causes and Corrective Actions

### AL028: Encoder voltage error or the internal of the encoder is in error

Causes	Checking Method	Corrective Actions
Battery voltage is too high	<ol style="list-style-type: none"> <li>1. Check if the charging circuit exists in the servo drive.</li> <li>2. Check if the battery is correctly installed</li> </ol>	According to the procedure of Over voltage to check. When corrective actions are done, AL.028 will be cleared automatically.
The internal encoder is in error.	<ol style="list-style-type: none"> <li>1. Check if it is the absolute type encoder.</li> <li>2. Check if the servo is properly grounded.</li> <li>3. Check if the encoder cable separates from the power supply or the high-current circuit to avoid the interference.</li> <li>4. Check if the shielding cables are used in the wiring of the encoder.</li> </ol>	<ol style="list-style-type: none"> <li>1. If the situation is not improving, please send the drive back to the distributors or contact with Delta.</li> <li>2. Please connect the UVW connector (color green) to the heat sink of the servo drive.</li> <li>3. Please check if the encoder cable separates from the power supply or the high-current circuit.</li> <li>4. Please use shielding mesh. If the situation is not improving, please send the drive back to the distributors or contact with Delta.</li> </ol>

### AL029: Gray code error

Causes	Checking Method	Corrective Actions
Absolute position is in error	Re-power on to operate the motor and check if the alarm will occur again.	If the alarm occurs again, please change the encoder.

### AL060: Absolute Position Lost

Causes	Checking Method	Corrective Actions
Battery under voltage	Check if the voltage of the battery is lower than 2.8V.	After change the battery, conduct homing procedure again. Please refer to the description of absolute coordinate initialization in Chapter 12.
Change the battery when the power is OFF which is controlled by the servo drive	Do no change or remove the battery when the power is OFF which is controlled by the servo drive.	Conduct homing procedure again. Please refer to the description of absolute coordinate initialization in Chapter 12.
After activating the absolute function, the absolute coordinate initialization has not been completed.	<ol style="list-style-type: none"> <li>1. Install the battery.</li> <li>2. Check the wiring between the battery pack and the power cable of the servo drive.</li> <li>3. Check the wiring of the encoder.</li> </ol>	Conduct homing procedure. Please refer to the description of absolute coordinate initialization in Chapter 12.
Bad connection of the battery power circuit	<ol style="list-style-type: none"> <li>1. Check the wiring of the encoder.</li> <li>2. Check the wiring between the battery pack and the power cable of the servo drive.</li> </ol>	Connect or repair the wiring of the battery so as to supply the power to the encoder. Conduct homing procedure again. Please refer to the description

Causes	Checking Method	Corrective Actions
		of absolute coordinate initialization in Chapter 12.

**AL062: Encoder under voltage**

Causes	Checking Method	Corrective Actions
Battery under voltage	<ol style="list-style-type: none"> <li>1. Check if the voltage of the battery on the panel is lower than 3.1 V (tentative specification).</li> <li>2. Measure if the voltage of the battery is lower than 3.1 V (tentative specification).</li> </ol>	Do not change the battery when the power is ON which is controlled by the servo drive. After change the battery, AL061 will be cleared automatically.

**AL062: The multi-turn of absolute encoder overflows**

Potential Cause	Checking Method	Corrective Actions
The operation distance exceeds the range the absolute encoder is able to record	Check if the operation distance exceeds the range, -32768 ~ +32767, the absolute encoder is able to record.	Conduct homing procedure again. Please refer to the description of absolute coordinate initialization in Chapter 12.

**AL068: Absolute data transmitted via I/O is in error**

Causes	Checking Method	Corrective Actions
Sequence error	<ol style="list-style-type: none"> <li>1. Switch OFF DI ABSQ should wait until DO ABSR is OFF.</li> <li>2. Switch ON ABSQ should wait until DO ABSR is ON.</li> </ol>	Correct the reading sequence of I/O
Reading time out	Check if the time between switching ON DO ABSR and switching ON ABSQ exceeds 200ms.	After switching ON DO ABSR (the absolute position data is ready), read DO ABSD and switch ON DI ABSQ within 200ms so that to inform the servo drive data reading is completed.

**AL069: Wrong motor type**

Causes	Checking Method	Corrective Actions
Incremental motor is not allowed to activate the absolute function	<ol style="list-style-type: none"> <li>1. Check if the motor is incremental or absolute encoder.</li> <li>2. Check parameter P2-69.</li> </ol>	If the user desires to use absolute function, please choose absolute motor. If not, please set parameter P2-69 to 0.

**AL289: Feedback position counter overflows**

Causes	Checking Method	Corrective Actions
Feedback position counter overflows	This alarm will not occur at the moment. If it does, please contact the distributors.	NMT: Reset node or 0x6040.Fault Reset

## 12.8 Related Monitoring Variables

Code	Monitoring Variables / Attribute	Explanation
038 (26h)	Voltage level of battery	The voltage level of battery for an absolute encoder.

(This page is intentionally left blank.)

# Appendix A Accessories

---

## ■ Power Connectors

Delta Part Number: ASDBCAPW0000 (for 200V series servo drive)

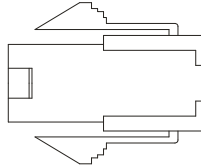

Delta Part Number: ASDBCAPW0100 (for 200V series servo drive, with brake contact)

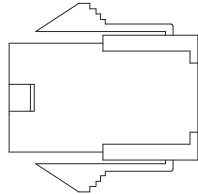

Delta Part Number: ASD-CAPW5400 (for 400V series servo drive)

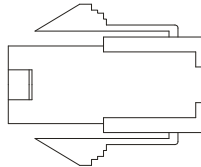

Delta Part Number: ASD-CAPW5100 (for 400V series servo drive, with brake contact)

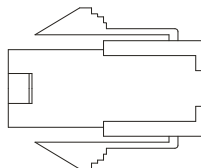

Delta Part Number: ASD-CAPW1000

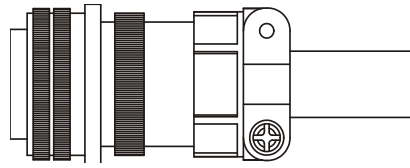

3106A-20-18S

Delta Part Number: ASD-CAPW2000

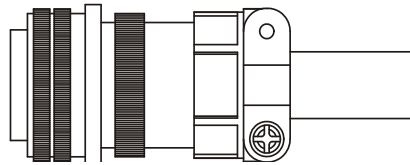

3106A-24-11S

Delta Part Number: ASD-CAPW4000

CLAMP: WPS3057-20A

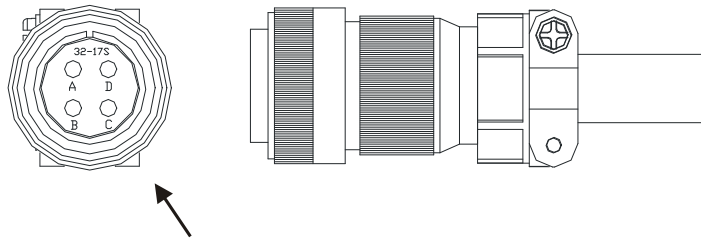

Straight Plug WPS3106A-32-17S

Motor Brake Connector: ASD-CNBR1000

CLAMP: WPS3106A 10SL-4S-R

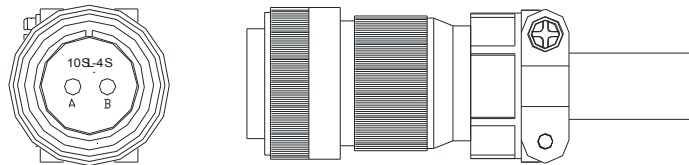

## ■ Power Cables

Delta Part Number: ASD-ABPW0003, ASD-ABPW0005 (for 200V series servo drive)

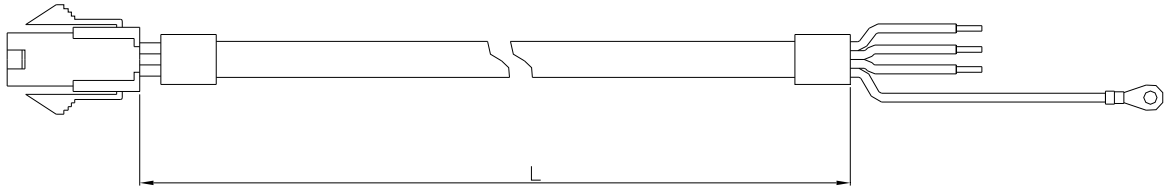

Title	Part No.	L	
		mm	inch
1	ASD-ABPW0003	$3000 \pm 100$	$118 \pm 4$
2	ASD-ABPW0005	$5000 \pm 100$	$197 \pm 4$

Delta Part Number: ASD-CAPW5403, ASD-CAPW5405 (for 400V series servo drive)

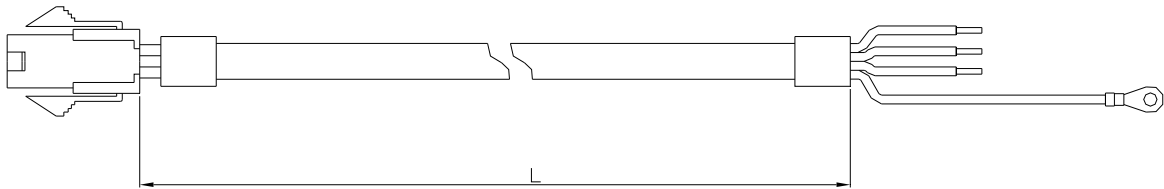

Title	Part No.	L	
		mm	inch
1	ASD-CAPW5403	$3000 \pm 100$	$118 \pm 4$
2	ASD-CAPW5405	$5000 \pm 100$	$197 \pm 4$



Delta Part Number: ASD-ABPW0103, ASD-ABPW0105  
 (for 200V series servo drive, with brake cable)

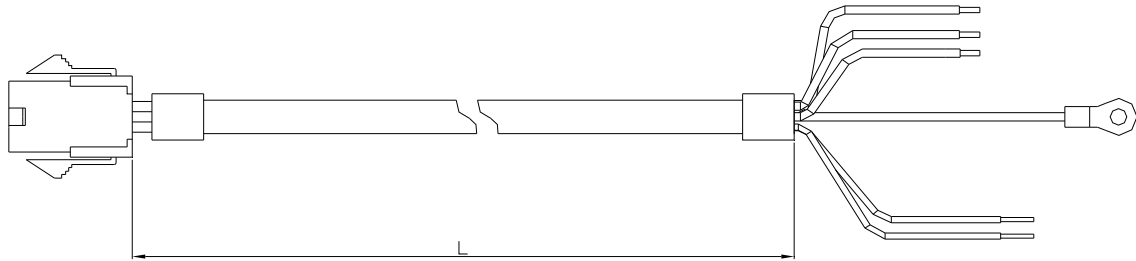

Title	Part No.	L	
		mm	inch
1	ASD- ABPW0103	3000 ± 100	118 ± 4
2	ASD- ABPW0105	5000 ± 100	197 ± 4

Delta Part Number: ASD-CAPW5103, ASD-CAPW5105  
 (for 400V series servo drive, with brake cable)

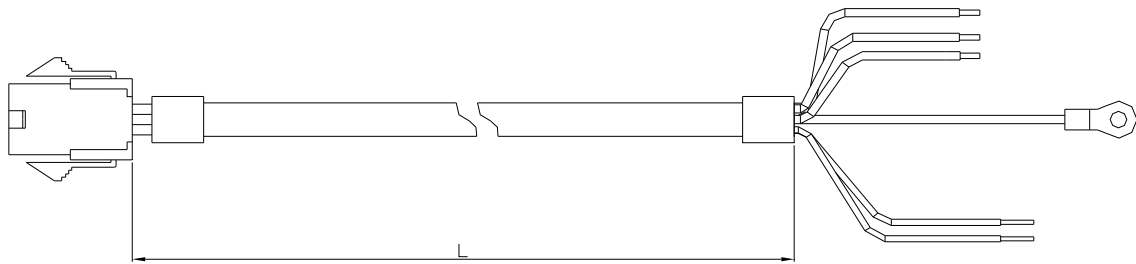

Title	Part No.	L	
		mm	inch
1	ASD- CAPW5103	3000 ± 100	118 ± 4
2	ASD- CAPW5105	5000 ± 100	197 ± 4

Delta Part Number: ASD-CAPW1003, ASD-CAPW1005

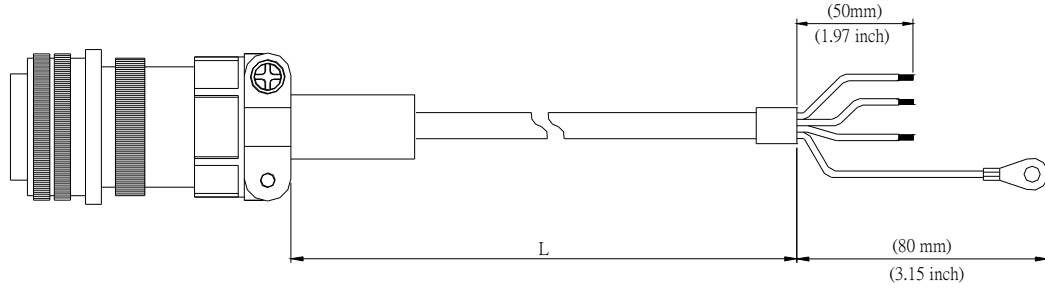

Title	Part No.	Straight	L	
			mm	inch
1	ASD-CAPW1003	3106A-20-18S	3000 ± 100	118 ± 4
2	ASD-CAPW1005	3106A-20-18S	5000 ± 100	197 ± 4

Delta Part Number: ASD-CAPW1103, ASD-CAPW1105

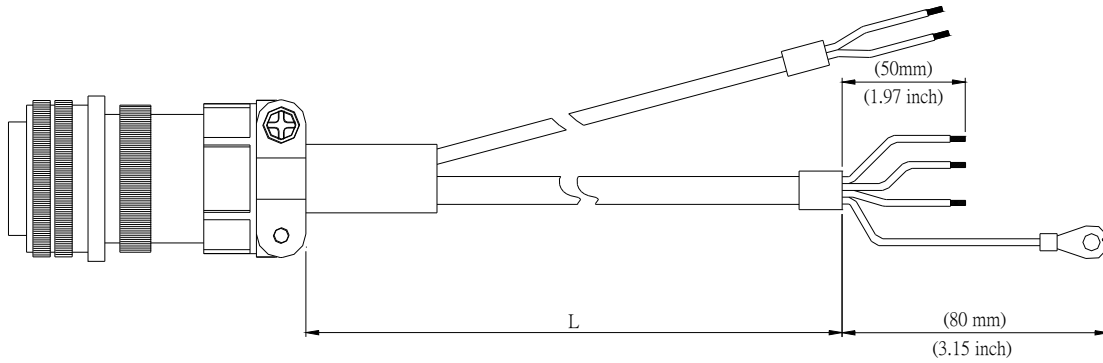

Title	Part No.	Straight	L	
			mm	inch
1	ASD-CAPW1103	3106A-20-18S	3000 ± 100	118 ± 4
2	ASD-CAPW1105	3106A-20-18S	5000 ± 100	197 ± 4

Delta Part Number: ASDB-CAPW1203, ASDB-CAPW1205

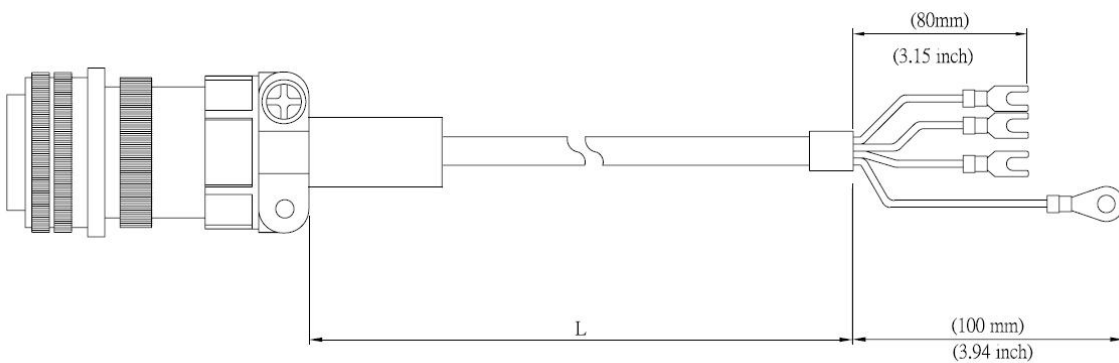

Title	Part No.	Straight	L	
			mm	inch
1	ASD-CAPW1203	3106A-20-18S	3000 ± 100	118 ± 4
2	ASD-CAPW1205	3106A-20-18S	5000 ± 100	197 ± 4

Delta Part Number: ASD-CAPW1303, ASD-CAPW1305

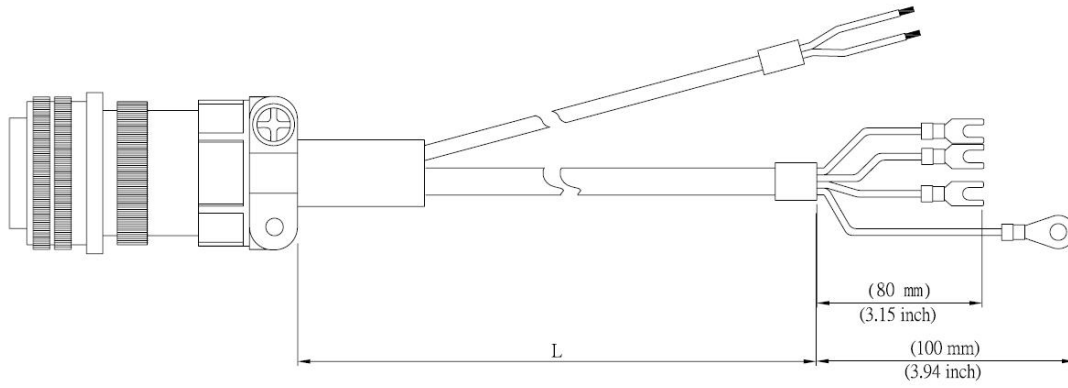

Title	Part No.	Straight	L	
			mm	inch
1	ASD-CAPW1303	3106A-20-18S	3000 ± 100	118 ± 4
2	ASD-CAPW1305	3106A-20-18S	5000 ± 100	197 ± 4

Delta Part Number: ASD-A2PW1003, ASD-A2PW1005

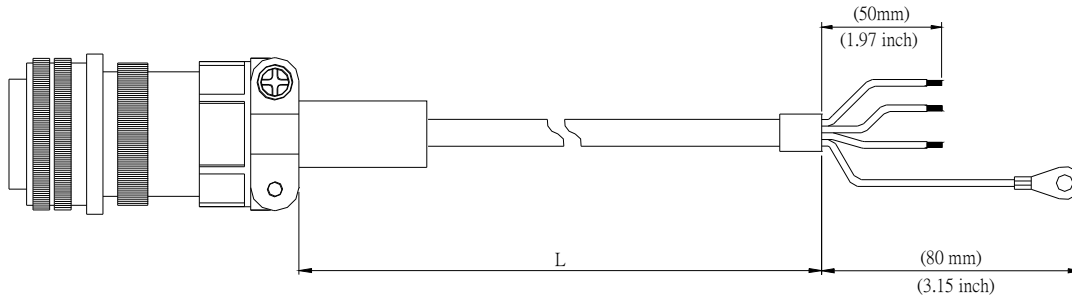

Title	Part No.	Straight	L	
			mm	inch
1	ASD-A2PW1003	3106A-20-18S	3000 ± 100	118 ± 4
2	ASD-A2PW1005	3106A-20-18S	5000 ± 100	197 ± 4

Delta Part Number: ASD-A2PW1103, ASD-A2PW1105

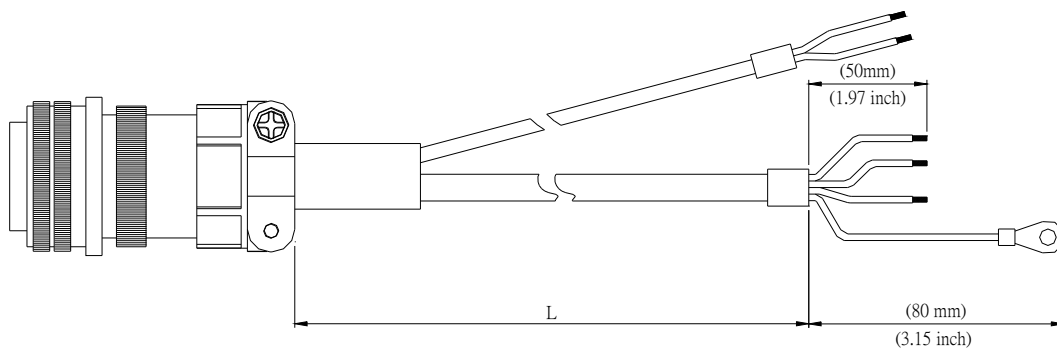

Title	Part No.	Straight	L	
			mm	inch
1	ASD-A2PW1103	3106A-20-18S	3000 ± 100	118 ± 4
2	ASD-A2PW1105	3106A-20-18S	5000 ± 100	197 ± 4

Delta Part Number: ASD-CAPW2003, ASD-CAPW2005

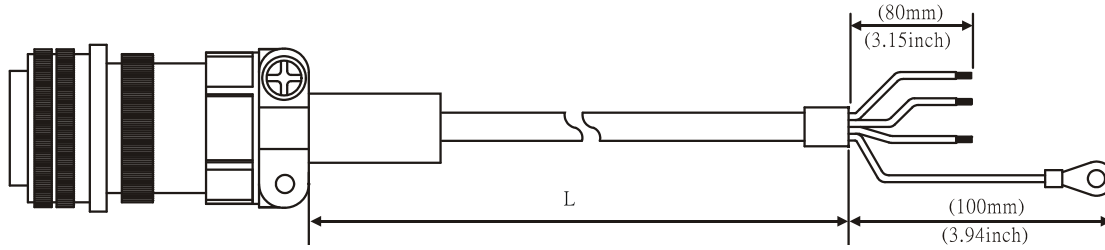

Title	Part No.	Straight	L	
			mm	inch
1	ASD-CAPW2003	3106A-20-18S	3000 ± 100	118 ± 4
2	ASD-CAPW2005	3106A-20-18S	5000 ± 100	197 ± 4

Delta Part Number: ASD-CAPW2103, ASD-CAPW2105

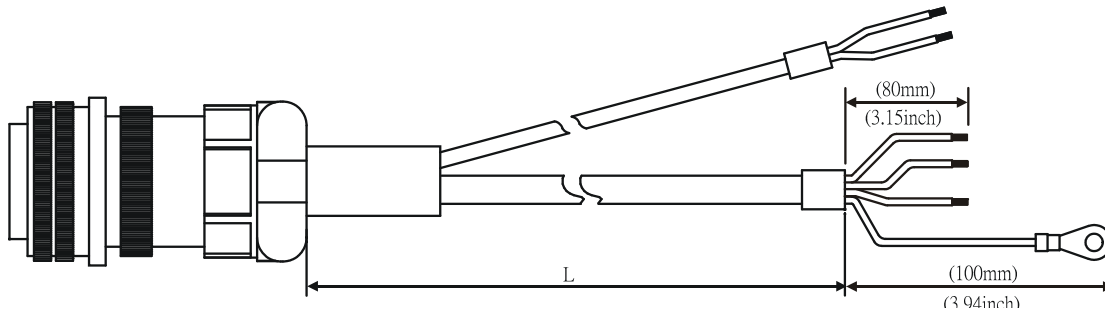

Title	Part No.	Straight	L	
			mm	inch
1	ASD-CAPW2103	3106A-20-18S	3000 ± 100	118 ± 4
2	ASD-CAPW2105	3106A-20-18S	5000 ± 100	197 ± 4

Delta Part Number: ASD-CAPW2203, ASD-CAPW2205

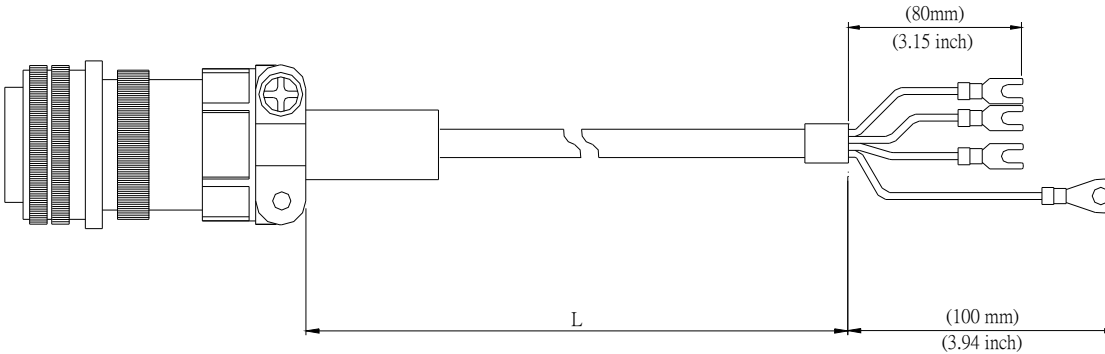

Title	Part No.	Straight	L	
			mm	inch
1	ASD-CAPW2203	3106A-20-18S	3000 ± 100	118 ± 4
2	ASD-CAPW2205	3106A-20-18S	5000 ± 100	197 ± 4

Delta Part Number: ASD-CAPW2303, ASD-CAPW2305 (for motors with brake)

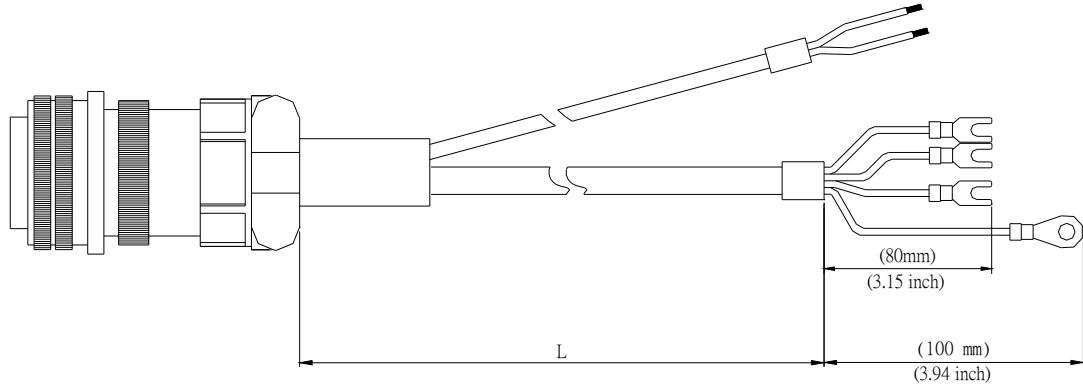

Title	Part No.	Straight	L	
			mm	inch
1	ASD-CAPW2303	3106A-20-18S	3000 ± 100	118 ± 4
2	ASD-CAPW2305	3106A-20-18S	5000 ± 100	197 ± 4

Delta Part Number: ASD-CAPW3203, ASD-CAPW3205 (for 4.5 kW models)

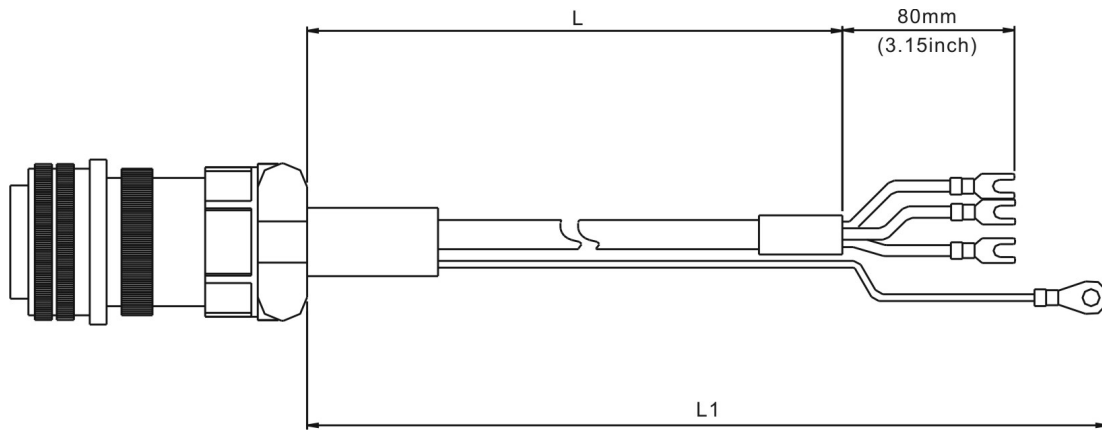

Title	Part No.	Straight	L	
			mm	inch
1	ASD-CAPW3203	MS 3106-24-11S	3000 ± 100	118 ± 4
2	ASD-CAPW3205	MS 3106-24-11S	5000 ± 100	197 ± 4

Delta Part Number: ASD-CAPW3303, ASD-CAPW3305 (for motors with brake)

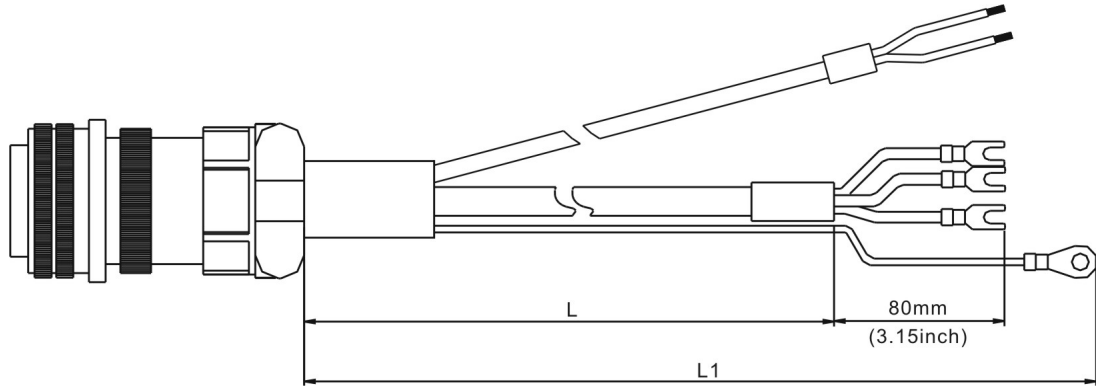

Item	Part No.	Straight	L		L1	
			mm	inch	mm	inch
1	ASD-CAPW3303	MS 3106-24-11S	3000±100	118 ± 4	3100±100	122 ± 4
2	ASD-CAPW3305	MS 3106-24-11S	5000±100	197 ± 4	5100±100	201 ± 4

■ Encoder Connectors

Delta Part Number: ASD-ABEN0000

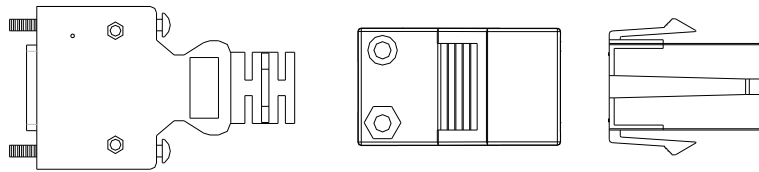

Delta Part Number: ASD-ABEN1000

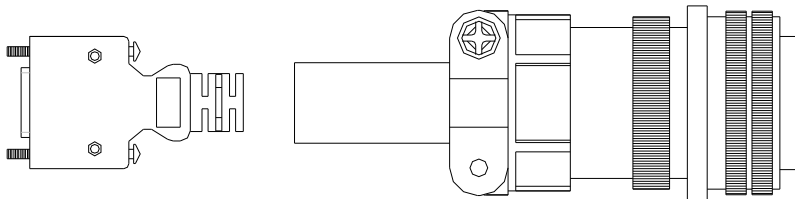

■ Incremental Type Encoder Cables

Delta Part Number: ASD-ABEN0003, ASD-ABEN0005

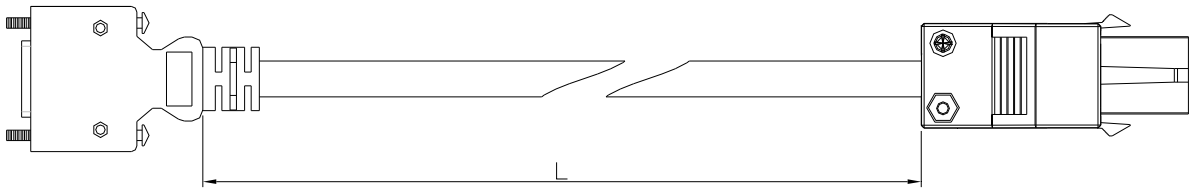

Title	Part No.	L	
		mm	inch
1	ASD-ABEN0003	3000 ± 100	118 ± 4
2	ASD-ABEN0005	5000 ± 100	197 ± 4

Delta Part Number: ASD-ABEN1003, ASD-ABEN1005

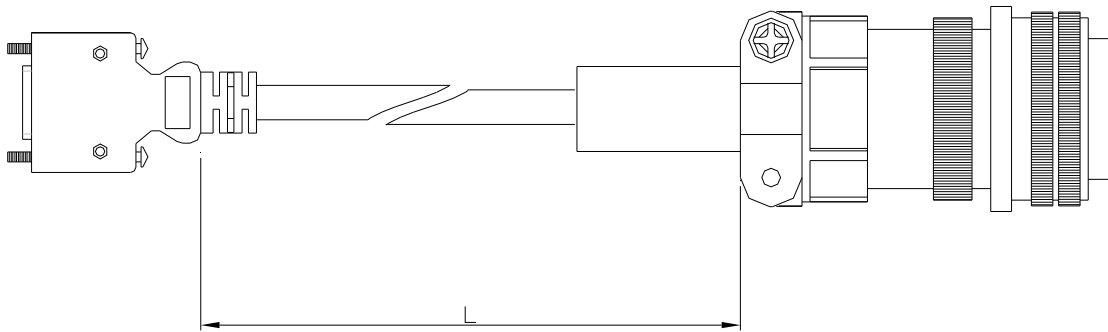

Title	Part No.	Straight	L	
			mm	inch
1	ASD-CAEN1003	3106A-20-29S	3000 ± 100	118 ± 4
2	ASD-CAEN1005	3106A-20-29S	5000 ± 100	197 ± 4

■ Absolute Type Encoder Cables

Delta Part Number: ASD-A2EB0003, ASD-A2EB0005

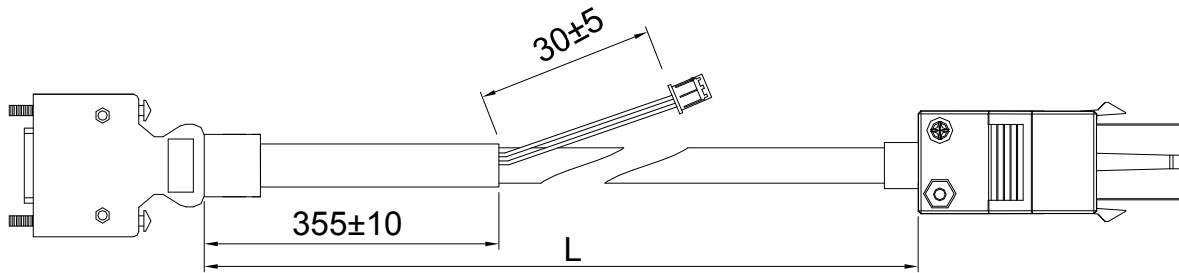

Title	Part No.	L	
		mm	inch
1	ASD-A2EB0003	3000 ± 100	118 ± 4
2	ASD-A2EB0005	5000 ± 100	197 ± 4

Delta Part Number: ASD-A2EB1003, ASD-A2EB1005

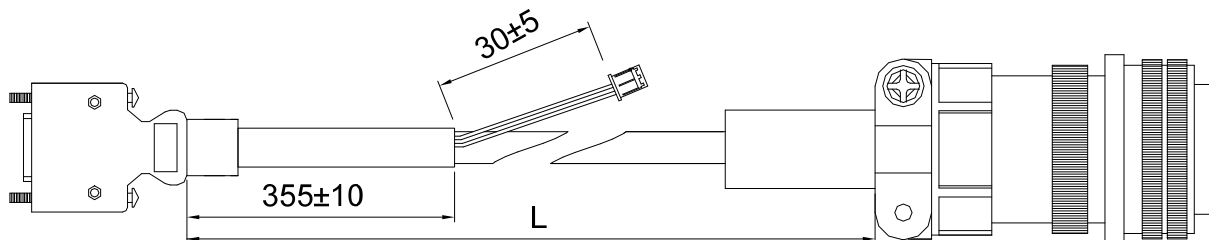

Title	Part No.	Manufacturer
MOTOR SIDE	3106A-20-29S	-
DRIVE SIDE	PLUG	3M 10120-3000PE
	SHELL	3M 10320-52A0-008

Title	Model Name	L	
		mm	inch
1	ASD-A2EB1003	3000 ± 100	118 ± 4
2	ASD-A2EB1005	5000 ± 100	197 ± 4



■ **Battery Box Cord AW (Connects to the battery side of the encoder cable)**

Delta Part Number: 3864573700

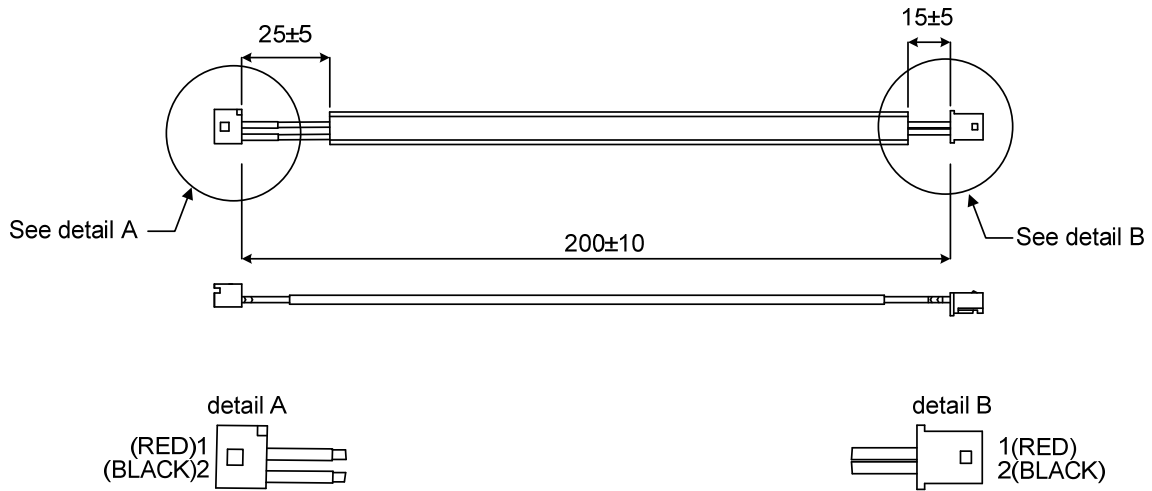

■ **Battery Box Cord IW (Connects to CN8)**

Delta Part Number: 3864811900

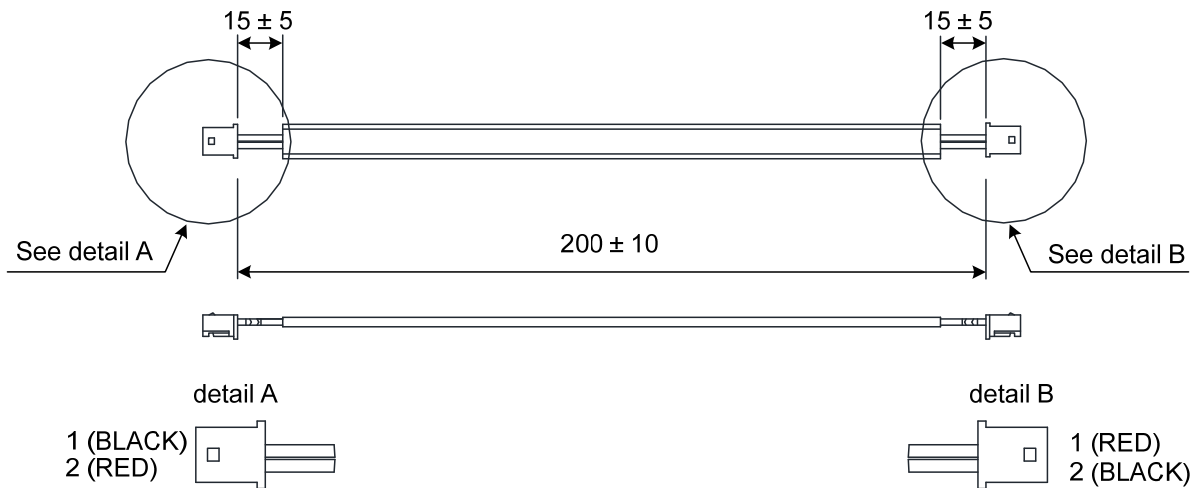

### ■ Battery Boxes

#### Single Battery Box

Delta Part Number: ASD-MDBT0100

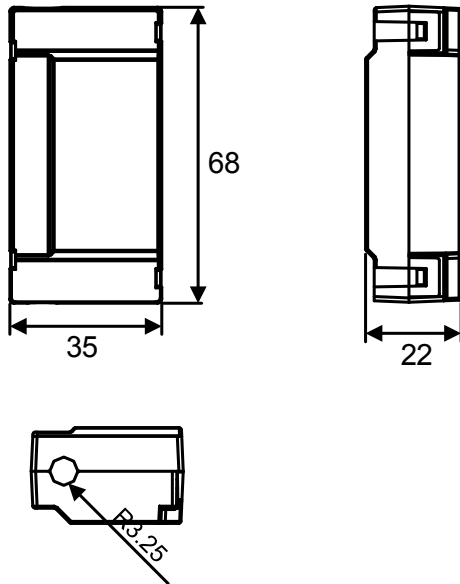

Units: mm

#### Dual Battery Box

Delta Part Number: ASD-MDBT0200

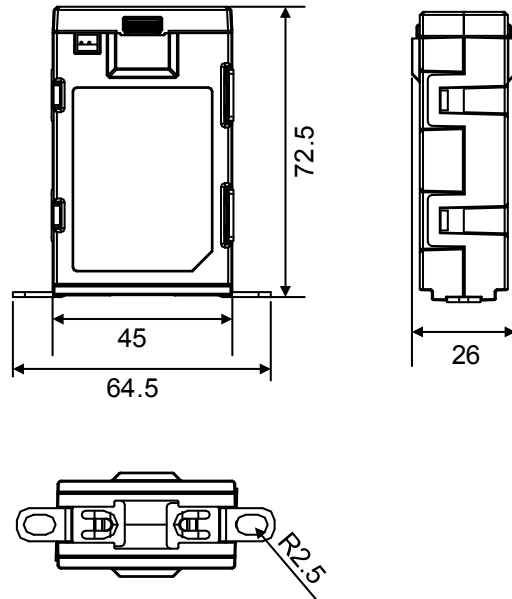

Units: mm

### ■ I/O Signal Connector

Delta Part Number: ASD-CN5C0050

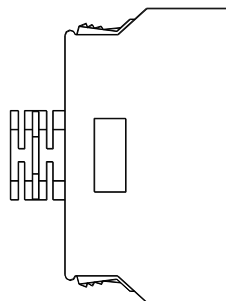

### ■ I/O Terminal Block Module

Delta Part Number: ASD-BM-50A

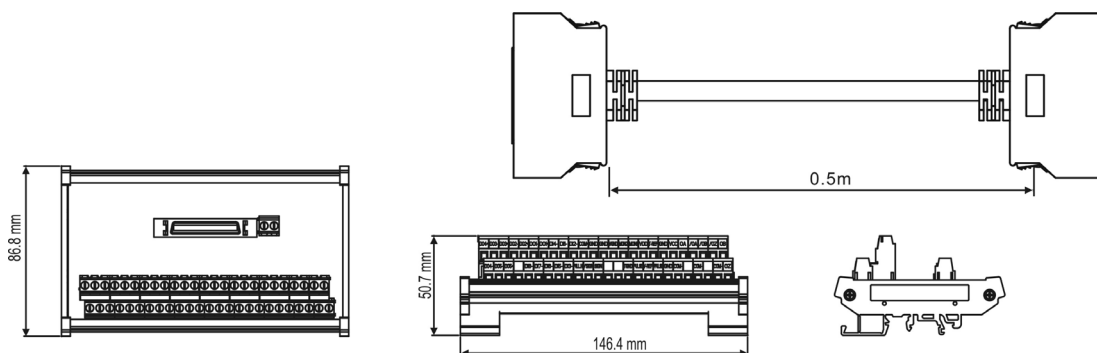

■ **RS-232 Communication Cable**

Delta Part Number: ASD-CARS0003

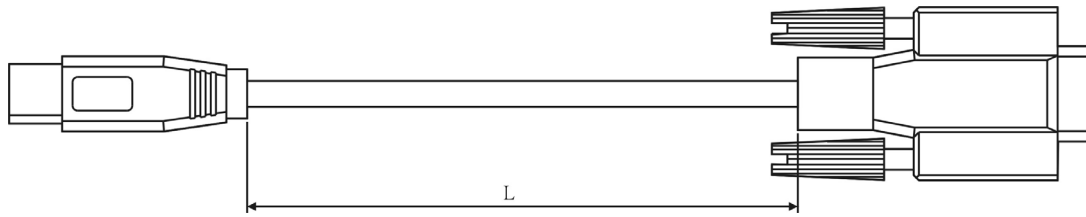

Title	Part No.	L	
		mm	inch
1	ASD-CARS0003	3000 ± 100	118 ± 4

■ **Communication Cable between Drive and Computer (for PC)**

Delta Part Number: DOP-CAUSBAB

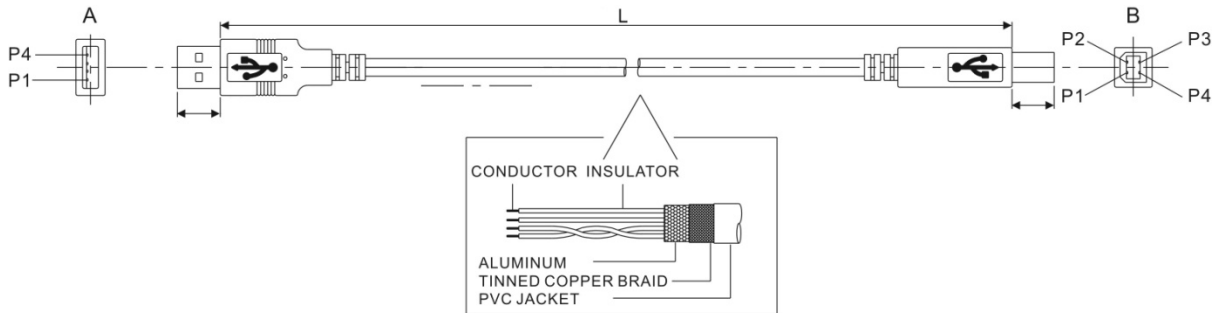

Title	Part No.	L	
		mm	inch
1	DOP-CAUSBAB	1400 ± 30	55 ± 1.2

■ **CANopen Communication Cable**

Delta Part Number: TAP-CB03, TAP-CB05

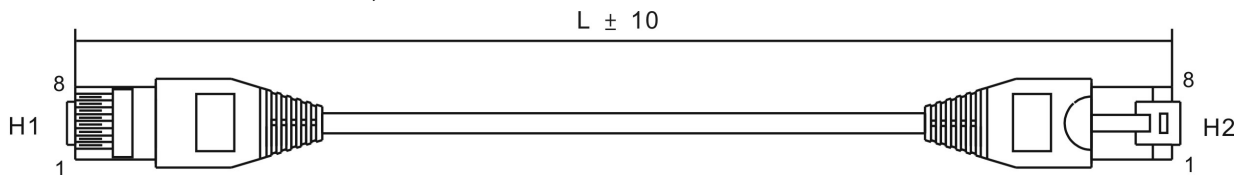

Title	Part No.	L	
		mm	inch
1	TAP-CB03	300 ± 10	11 ± 0.4
2	TAP-CB05	500 ± 10	19 ± 0.4

### ■ CANopen Distribution Box

Delta Part Number: TAP-CN03

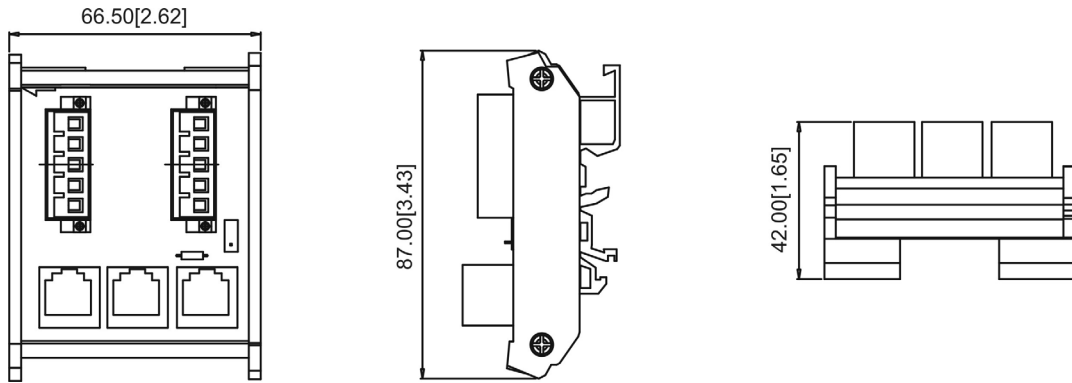

### ■ RS-485 Connector

Delta Part Number: ASD-CNIE0B06

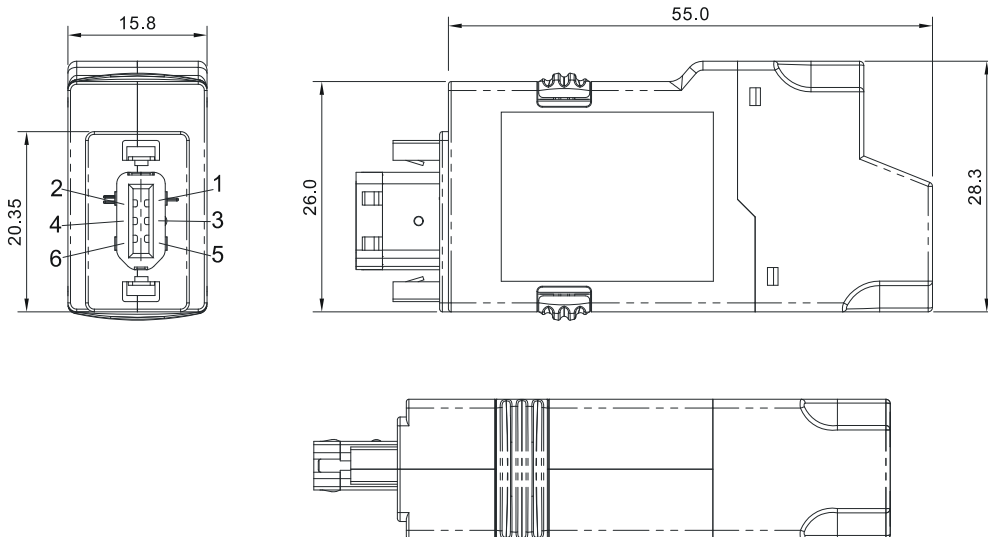

■ CN1 Convenient Connector

Delta Part Number: ASD-IF-SC5020

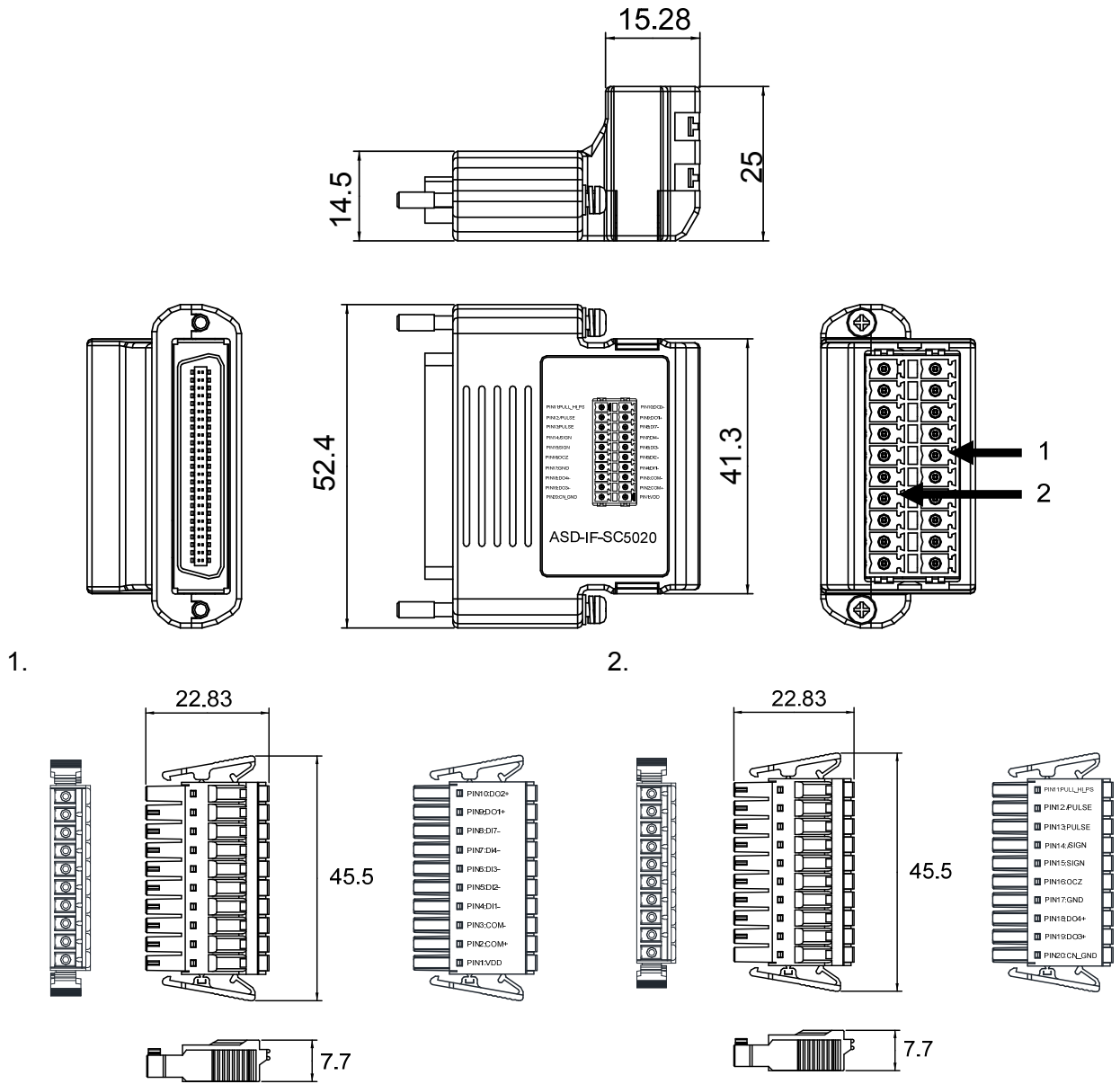

## ■ Optional Accessories - 220V Series

### 100W Servo Drive and 50W Low Inertia Servo Motor

Servo Drive	ASD-A2-0121-□
Low Inertia Servo Motor	ECMA-C△040F□S
Motor Power Cable (Without Brake)	ASD-ABPW000X
Power Connector (Without Brake)	ASDBCAPW0000
Motor Power Cable (With Brake)	ASD-ABPW010X
Power Connector (With Brake)	ASDBCAPW0100
Incremental Type Encoder Cable	ASD-ABEN000X
Absolute Type Encoder Cable	ASD-A2EB000X
Encoder Connector	ASD-ABEN0000

(X=3 indicates that the cable length is 3m; X=5 indicates that the cable length is 5m)

### 100W Servo Drive and 100W Low Inertia Servo Motor

Servo Drive	ASD-A2-0121-□
Low Inertia Servo Motor	ECMA-C△0401□S
Motor Power Cable (Without Brake)	ASD-ABPW000X
Power Connector (Without Brake)	ASDBCAPW0000
Motor Power Cable (With Brake)	ASD-ABPW010X
Power Connector (With Brake)	ASDBCAPW0100
Incremental Type Encoder Cable	ASD-ABEN000X
Absolute Type Encoder Cable	ASD-A2EB000X
Encoder Connector	ASD-ABEN0000

(X=3 indicates that the cable length is 3m; X=5 indicates that the cable length is 5m)

## 200W Servo Drive and 200W Low Inertia Servo Motor

Servo Drive	ASD-A2-0221-□
Low Inertia Servo Motor	ECMA-C△0602□S
Motor Power Cable (Without Brake)	ASD-ABPW000X
Power Connector (Without Brake)	ASDBCAPW0000
Motor Power Cable (With Brake)	ASD-ABPW010X
Power Connector (With Brake)	ASDBCAPW0100
Incremental Type Encoder Cable	ASD-ABEN000X
Absolute Type Encoder Cable	ASD-A2EB000X
Encoder Connector	ASD-ABEN0000

(X=3 indicates that the cable length is 3m; X=5 indicates that the cable length is 5m)

## 400W Servo Drive and 400W Low Inertia Servo Motor

Servo Drive	ASD-A2-0421-□
Low Inertia Servo Motor	ECMA-C△0604□S ECMA-C△0604□H ECMA-C△0804□7
Motor Power Cable (Without Brake)	ASD-ABPW000X
Power Connector (Without Brake)	ASDBCAPW0000
Motor Power Cable (With Brake)	ASD-ABPW010X
Power Connector (With Brake)	ASDBCAPW0100
Incremental Type Encoder Cable	ASD-ABEN000X
Absolute Type Encoder Cable	ASD-A2EB000X
Encoder Connector	ASD-ABEN0000

(X=3 indicates that the cable length is 3m; X=5 indicates that the cable length is 5m)

## 400W Servo Drive and 500W Medium Inertia Servo Motor

Servo Drive	ASD-A2-0421-□
Medium Inertia Servo Motor	ECMA-E△1305□S
Motor Power Cable (Without Brake)	ASD-CAPW100X
Motor Power Cable (With Brake)	ASD-CAPW110X
Power Connector	ASD-CAPW1000
Incremental Type Encoder Cable	ASD-CAEN100X
Absolute Type Encoder Cable	ASD-A2EB100X
Encoder Connector	ASD-CAEN1000

(X=3 indicates that the cable length is 3m; X=5 indicates that the cable length is 5m)

## 400W Servo Drive and 300W High Inertia Servo Motor

Servo Drive	ASD-A2-0421-□
High Inertia Servo Motor	ECMA-G△1303□S
Motor Power Cable (Without Brake)	ASD-CAPW100X
Motor Power Cable (With Brake)	ASD-CAPW110X
Power Connector	ASD-CAPW1000
Incremental Type Encoder Cable	ASD-CAEN100X
Absolute Type Encoder Cable	ASD-A2EB100X
Encoder Connector	ASD-CAEN1000

(X=3 indicates that the cable length is 3m; X=5 indicates that the cable length is 5m)

## 750W Servo Drive and 750W Low Inertia Servo Motor

Servo Drive	ASD-A2-0721-□
Low Inertia Servo Motor	ECMA-C△0807□S ECMA-C△0807□H ECMA-C△0907□S
Motor Power Cable (Without Brake)	ASD-ABPW000X
Power Connector (Without Brake)	ASDBCAPW0000
Motor Power Cable (With Brake)	ASD-ABPW010X
Power Connector (With Brake)	ASDBCAPW0100
Incremental Type Encoder Cable	ASD-ABEN000X
Absolute Type Encoder Cable	ASD-A2EB000X
Encoder Connector	ASD-ABEN0000

(X=3 indicates that the cable length is 3m; X=5 indicates that the cable length is 5m)

## 750W Servo Drive and 500W Medium-High Inertia Servo Motor

Servo Drive	ASD-A2-0721-□
Medium-High Inertia Servo Motor	ECMA-F△1305□S
Motor Power Cable (Without Brake)	ASD-CAPW100X
Motor Power Cable (With Brake)	ASD-CAPW110X
Power Connector	ASD-CAPW1000
Incremental Type Encoder Cable	ASD-CAEN100X
Absolute Type Encoder Cable	ASD-A2EB100X
Encoder Connector	ASD-CAEN1000

(X=3 indicates that the cable length is 3m; X=5 indicates that the cable length is 5m)



## 750W Servo Drive and 600W High Inertia Servo Motor

Servo Drive	ASD-A2-0721-□
High Inertia Servo Motor	ECMA-G△1306□S
Motor Power Cable (Without Brake)	ASD-CAPW100X
Motor Power Cable (With Brake)	ASD-CAPW110X
Power Connector	ASD-CAPW1000
Incremental Type Encoder Cable	ASD-CAEN100X
Absolute Type Encoder Cable	ASD-A2EB100X
Encoder Connector	ASD-CAEN1000

(X=3 indicates that the cable length is 3m; X=5 indicates that the cable length is 5m)

## 1kW Servo Drive and 1kW Low Inertia Servo Motor

Servo Drive	ASD-A2-1021-□
Low Inertia Servo Motor	ECMA-C△1010□S
Motor Power Cable (Without Brake)	ASD-CAPW100X
Motor Power Cable (With Brake)	ASD-CAPW110X
Power Connector	ASD-CAPW1000
Incremental Type Encoder Cable	ASD-CAEN100X
Absolute Type Encoder Cable	ASD-A2EB100X
Encoder Connector	ASD-CAEN1000

(X=3 indicates that the cable length is 3m; X=5 indicates that the cable length is 5m)

## 1Kw Servo Drive and 1kW Low Inertia Servo Motor

Servo Drive	ASD-A2-1021-□
Low Inertia Servo Motor	ECMA-C△0910□S
Motor Power Cable (Without Brake)	ASD-ABPW000X
Motor Power Cable (With Brake)	ASD-ABPW010X
Incremental Type Encoder Cable	ASD-ABEN000X
Absolute Type Encoder Cable	ASD-A2EB000X
Encoder Connector	ASD-ABEN0000

(X=3 indicates that the cable length is 3m; X=5 indicates that the cable length is 5m)

## 1kW Servo Drive and 1kW Medium Inertia Servo Motor

Servo Drive	ASD-A2-1021-□
Medium Inertia Servo Motor	ECMA-E△1310□S
Motor Power Cable (Without Brake)	ASD-CAPW100X
Motor Power Cable (With Brake)	ASD-CAPW110X
Power Connector	ASD-CAPW1000
Incremental Type Encoder Cable	ASD-CAEN100X
Absolute Type Encoder Cable	ASD-A2EB100X
Encoder Connector	ASD-CAEN1000

(X=3 indicates that the cable length is 3m; X=5 indicates that the cable length is 5m)

## 1kW Servo Drive and 850W Medium-High Inertia Servo Motor

Servo Drive	ASD-A2-1021-□
Medium-High Inertia Servo Motor	ECMA-F△1308□S
Motor Power Cable (Without Brake)	ASD-CAPW100X
Motor Power Cable (With Brake)	ASD-CAPW110X
Power Connector	ASD-CAPW1000
Incremental Type Encoder Cable	ASD-CAEN100X
Absolute Type Encoder Cable	ASD-A2EB100X
Encoder Connector	ASD-CAEN1000

(X=3 indicates that the cable length is 3m; X=5 indicates that the cable length is 5m)

## 1kW Servo Drive and 900W High Inertia Servo Motor

Servo Drive	ASD-A2-1021-□
High Inertia Servo Motor	ECMA-G△1309□S
Motor Power Cable (Without Brake)	ASD-CAPW100X
Motor Power Cable (With Brake)	ASD-CAPW110X
Power Connector	ASD-CAPW1000
Incremental Type Encoder Cable	ASD-CAEN100X
Absolute Type Encoder Cable	ASD-A2EB100X
Encoder Connector	ASD-CAEN1000

(X=3 indicates that the cable length is 3m; X=5 indicates that the cable length is 5m)

## 1.5kW Servo Drive and 1.5kW Medium Inertia Servo Motor

Servo Drive	ASD-A2-1521-□
Medium Inertia Servo Motor	ECMA-E△1315□S
Motor Power Cable (Without Brake)	ASD-CAPW100X
Motor Power Cable (With Brake)	ASD-CAPW110X
Power Connector	ASD-CAPW1000
Incremental Type Encoder Cable	ASD-CAEN100X
Absolute Type Encoder Cable	ASD-A2EB100X
Encoder Connector	ASD-CAEN1000

(X=3 indicates that the cable length is 3m; X=5 indicates that the cable length is 5m)

## 2kW Servo Drive and 2kW Low Inertia Servo Motor

Servo Drive	ASD-A2-2023-□
Low Inertia Servo Motor	ECMA-C△1020□S
Motor Power Cable (Without Brake)	ASD-A2PW100X
Motor Power Cable (With Brake)	ASD-A2PW110X
Power Connector	ASD-CAPW1000
Incremental Type Encoder Cable	ASD-CAEN100X
Absolute Type Encoder Cable	ASD-A2EB100X
Encoder Connector	ASD-CAEN1000

(X=3 indicates that the cable length is 3m; X=5 indicates that the cable length is 5m)

## 2kW Servo Drive and 2kW Medium Inertia Servo Motor

Servo Drive	ASD-A2-2023-□
Medium Inertia Servo Motor	ECMA-E△1320□S
Motor Power Cable (Without Brake)	ASD-A2PW100X
Motor Power Cable (With Brake)	ASD-A2PW110X
Power Connector	ASD-CAPW1000
Incremental Type Encoder Cable	ASD-CAEN100X
Absolute Type Encoder Cable	ASD-A2EB100X
Encoder Connector	ASD-CAEN1000

(X=3 indicates that the cable length is 3m; X=5 indicates that the cable length is 5m)

## 2kW Servo Drive and 2kW Medium Inertia Servo Motor

Servo Drive	ASD-A2-2023-□
Medium Inertia Servo Motor	ECMA-E△1820□S
Motor Power Cable (Without Brake)	ASD-CAPW200X
Motor Power Cable (With Brake)	ASD-CAPW210X
Power Connector	ASD-CAPW2000
Incremental Type Encoder Cable	ASD-CAEN100X
Absolute Type Encoder Cable	ASD-A2EB100X
Encoder Connector	ASD-CAEN1000

(X=3 indicates that the cable length is 3m; X=5 indicates that the cable length is 5m)

## 2kW Servo Drive and 1.3kW Medium-High Inertia Servo Motor

Servo Drive	ASD-A2-3023-□
Medium-High Inertia Servo Motor	ECMA-F△1313□S
Motor Power Cable (Without Brake)	ASD-A2PW100X
Motor Power Cable (With Brake)	ASD-A2PW110X
Power Connector	ASD-CAPW1000
Incremental Type Encoder Cable	ASD-CAEN100X
Absolute Type Encoder Cable	ASD-A2EB100X
Encoder Connector	ASD-CAEN1000

(X=3 indicates that the cable length is 3m; X=5 indicates that the cable length is 5m)

## 2kW Servo Drive and 1.8kW Medium-High Inertia Servo Motor

Servo Drive	ASD-A2-3023-□
Medium-High Inertia Servo Motor	ECMA-F△1318□S
Motor Power Cable (Without Brake)	ASD-A2PW100X
Motor Power Cable (With Brake)	ASD-A2PW110X
Power Connector	ASD-CAPW1000
Incremental Type Encoder Cable	ASD-CAEN100X
Absolute Type Encoder Cable	ASD-A2EB100X
Encoder Connector	ASD-CAEN1000

(X=3 indicates that the cable length is 3m; X=5 indicates that the cable length is 5m)

## 3kW Servo Drive and 3kW Low Inertia Servo Motor

Servo Drive	ASD-A2-3023-□
Low Inertia Servo Motor	ECMA-C△1330□4
Motor Power Cable (Without Brake)	ASD-CAPW100X
Motor Power Cable (With Brake)	ASD-CAPW110X
Power Connector	ASD-CAPW1000
Incremental Type Encoder Cable	ASD-CAEN100X
Absolute Type Encoder Cable	ASD-A2EB100X
Encoder Connector	ASD-CAEN1000

(X=3 indicates that the cable length is 3m; X=5 indicates that the cable length is 5m)

## 3kW Servo Drive and 3kW Medium Inertia Servo Motor

Servo Drive	ASD-A2-3023-□
Medium Inertia Servo Motor	ECMA-E△1830□S
Motor Power Cable (Without Brake)	ASD-CAPW200X
Motor Power Cable (With Brake)	ASD-CAPW210X
Power Connector	ASD-CAPW2000
Incremental Type Encoder Cable	ASD-CAEN100X
Absolute Type Encoder Cable	ASD-A2EB100X
Encoder Connector	ASD-CAEN1000

(X=3 indicates that the cable length is 3m; X=5 indicates that the cable length is 5m)

## 3kW Servo Drive and 3.5kW Medium Inertia Servo Motor

Servo Drive	ASD-A2-3023-□
Medium Inertia Servo Motor	ECMA-E△1835□S
Motor Power Cable (Without Brake)	ASD-CAPW200X
Motor Power Cable (With Brake)	ASD-CAPW210X
Power Connector	ASD-CAPW2000
Incremental Type Encoder Cable	ASD-CAEN100X
Absolute Type Encoder Cable	ASD-A2EB100X
Encoder Connector	ASD-CAEN1000

(X=3 indicates that the cable length is 3m; X=5 indicates that the cable length is 5m)

## 3kW Servo Drive and 3kW Medium-High Inertia Servo Motor

Servo Drive	ASD-A2-3023-□
Medium-High Inertia Servo Motor	ECMA-F△1830□S
Motor Power Cable (Without Brake)	ASD-CAPW200X
Motor Power Cable (With Brake)	ASD-CAPW210X
Power Connector	ASD-CAPW2000
Incremental Type Encoder Cable	ASD-CAEN100X
Absolute Type Encoder Cable	ASD-A2EB100X
Encoder Connector	ASD-CAEN1000

(X=3 indicates that the cable length is 3m; X=5 indicates that the cable length is 5m)

## 4.5kW Servo Drive and 4.5kW Medium-High Inertia Servo Motor

Servo Drive	ASD-A2-4523-□
Medium-High Inertia Servo Motor	ECMA-F△1845□S
Motor Power Cable (Without Brake)	ASD-CAPW320X
Motor Power Cable (With Brake)	ASD-CAPW330X
Power Connector	ASD-CAPW2000
Incremental Type Encoder Cable	ASD-CAEN100X
Absolute Type Encoder Cable	ASD-A2EB100X
Encoder Connector	ASD-CAEN1000

(X=3 indicates that the cable length is 3m; X=5 indicates that the cable length is 5m)

## 5.5kW Servo Drive and 5.5kW Medium-High Inertia Servo Motor

Servo Drive	ASD-A2-5523-□
Medium-High Inertia Servo Motor	ECMA-F△1855□3
Motor Power Cable (Without Brake)	-
Motor Power Cable (With Brake)	-
Power Connector	ASD-CAPW4000
Brake Connector	ASD-CNBR1000
Incremental Type Encoder Cable	ASD-CAEN100X
Absolute Type Encoder Cable	ASD-A2EB100X
Encoder Connector	ASD-CAEN1000

(X=3 indicates that the cable length is 3m; X=5 indicates that the cable length is 5m)

## 7.5kW Servo Drive and 7.5kW Medium-High Inertia Servo Motor

Servo Drive	ASD-A2-7523-□
Medium-High Inertia Servo Motor	ECMA-F△1875□3
Motor Power Cable (Without Brake)	-
Motor Power Cable (With Brake)	-
Power Connector	ASD-CAPW4000
Brake Connector	ASD-CNBR1000
Incremental Type Encoder Cable	ASD-CAEN100X
Absolute Type Encoder Cable	ASD-A2EB100X
Encoder Connector	ASD-CAEN1000

(X=3 indicates that the cable length is 3m; X=5 indicates that the cable length is 5m)

## 11kW Servo Drive and 11kW Medium-High Inertia Servo Motor

Servo Drive	ASD-A2-1B23-□
Medium-High Inertia Servo Motor	ECMA-F1221B□3
Motor Power Cable (Without Brake)	-
Motor Power Cable (With Brake)	-
Power Connector	ASD-CAPW4000
Brake Connector	ASD-CNBR1000
Incremental Type Encoder Cable	ASD-CAEN100X
Absolute Type Encoder Cable	ASD-A2EB100X
Encoder Connector	ASD-CAEN1000

(X=3 indicates that the cable length is 3m; X=5 indicates that the cable length is 5m)

## 15kW Servo Drive and 15kW Medium-High Inertia Servo Motor

Servo Drive	ASD-A2-1F23-□
Medium-High Inertia Servo Motor	ECMA-F1221F□S
Motor Power Cable (Without Brake)	-
Motor Power Cable (With Brake)	-
Power Connector	ASD-CAPW4000
Incremental Type Encoder Cable	ASD-CAEN100X
Absolute Type Encoder Cable	ASD-A2EB100X
Encoder Connector	ASD-CAEN1000

(X=3 indicates that the cable length is 3m; X=5 indicates that the cable length is 5m)



1. The boxes (□) at the ends of the servo drive model names are for optional configurations. Please refer to the ordering information of the actual purchased product.
2. The boxes (△) in the model names are for encoder resolution types. Please refer to Chapter 1 for further information.
3. The boxes (□) in the model names represent brake or keyway / oil seal.



## ■ Optional Accessories - 400V Series

### 750W Servo Drive and 400W Low Inertia Servo Motor

Servo Drive	ASD-A2-0743-□
Low Inertia Servo Motor	ECMA-J△0604□S
Motor Power Cable (Without Brake)	ASD-CAPW540X
Power Connector (Without Brake)	ASD-CAPW5400
Motor Power Cable (With Brake)	ASD-CAPW510X
Power Connector (With Brake)	ASD-CAPW5100
Incremental Type Encoder Cable	ASD-ABEN000X
Absolute Type Encoder Cable	ASD-A2EB000X
Encoder Connector	ASD-ABEN0000

(X=3 indicates that the cable length is 3m; X=5 indicates that the cable length is 5m)

### 750W Servo Drive and 750W Low Inertia Servo Motor

Servo Drive	ASD-A2-0743-□
Low Inertia Servo Motor	ECMA-J△0807□S ECMA-J△0907□S
Motor Power Cable (Without Brake)	ASD-CAPW540X
Power Connector (Without Brake)	ASD-CAPW5400
Motor Power Cable (With Brake)	ASD-CAPW510X
Power Connector (With Brake)	ASD-CAPW5100
Incremental Type Encoder Cable	ASD-ABEN000X
Absolute Type Encoder Cable	ASD-A2EB000X
Encoder Connector	ASD-ABEN0000

(X=3 indicates that the cable length is 3m; X=5 indicates that the cable length is 5m)

### 750W Servo Drive and 500W Medium Inertia Servo Motor

Servo Drive	ASD-A2-0743-□
Medium Inertia Servo Motor	ECMA- K△1305□S
Motor Power Cable (Without Brake)	ASD-CAPW100X
Motor Power Cable (With Brake)	ASD-CAPW110X
Power Connector	ASD-CAPW1000
Incremental Type Encoder Cable	ASD-CAEN100X
Absolute Type Encoder Cable	ASD-A2EB100X
Encoder Connector	ASD-CAEN1000

(X=3 indicates that the cable length is 3m; X=5 indicates that the cable length is 5m)

## 750W Servo Drive and 500W Medium-High Inertia Servo Motor

Servo Drive	ASD-A2-0743-□
Medium-High Inertia Servo Motor	ECMA- L△1305□S
Motor Power Cable (Without Brake)	ASD-CAPW100X
Motor Power Cable (With Brake)	ASD-CAPW110X
Power Connector	ASD-CAPW1000
Incremental Type Encoder Cable	ASD-CAEN100X
Absolute Type Encoder Cable	ASD-A2EB100X
Encoder Connector	ASD-CAEN1000

(X=3 indicates that the cable length is 3m; X=5 indicates that the cable length is 5m)

## 1kW Servo Drive and 1kW Low Inertia Servo Motor

Servo Drive	ASD-A2-1043-□
Low Inertia Servo Motor	ECMA-J△0910□S
Motor Power Cable (Without Brake)	ASD-CAPW540X
Power Connector (Without Brake)	ASD-CAPW5400
Motor Power Cable (With Brake)	ASD-CAPW510X
Power Connector (With Brake)	ASD-CAPW5100
Incremental Type Encoder Cable	ASD-ABEN000X
Absolute Type Encoder Cable	ASD-A2EB000X
Encoder Connector	ASD-ABEN0000

(X=3 indicates that the cable length is 3m; X=5 indicates that the cable length is 5m)

## 1kW Servo Drive and 850W High Inertia Servo Motor

Servo Drive	ASD-A2-1043-□
High Inertia Servo Motor	ECMA-L△1308□S
Motor Power Cable (Without Brake)	ASD-CAPW100X
Motor Power Cable (With Brake)	ASD-CAPW110X
Power Connector	ASD-CAPW1000
Incremental Type Encoder Cable	ASD-CAEN100X
Absolute Type Encoder Cable	ASD-A2EB100X
Encoder Connector	ASD-CAEN1000

(X=3 indicates that the cable length is 3m; X=5 indicates that the cable length is 5m)

## 1kW Servo Drive and 1kW Medium Inertia Servo Motor

Servo Drive	ASD-A2-1043-□
Medium Inertia Servo Motor	ECMA-K△1310□S
Motor Power Cable (Without Brake)	ASD-CAPW100X
Motor Power Cable (With Brake)	ASD-CAPW110X
Power Connector	ASD-CAPW1000
Incremental Type Encoder Cable	ASD-CAEN100X
Absolute Type Encoder Cable	ASD-A2EB100X
Encoder Connector	ASD-CAEN1000

(X=3 indicates that the cable length is 3m; X=5 indicates that the cable length is 5m)

## 1.5kW Servo Drive and 900W High Inertia Servo Motor

Servo Drive	ASD-A2-1543-□
High Inertia Servo Motor	ECMA-M△1309□S
Motor Power Cable (Without Brake)	ASD-CAPW100X
Motor Power Cable (With Brake)	ASD-CAPW110X
Power Connector	ASD-CAPW1000
Incremental Type Encoder Cable	ASD-CAEN100X
Absolute Type Encoder Cable	ASD-A2EB100X
Encoder Connector	ASD-CAEN1000

(X=3 indicates that the cable length is 3m; X=5 indicates that the cable length is 5m)

## 1.5kW Servo Drive and 1kW Low Inertia Servo Motor

Servo Drive	ASD-A2-1543-□
Low Inertia Servo Motor	ECMA-J△1010□S
Motor Power Cable (Without Brake)	ASD-CAPW100X
Motor Power Cable (With Brake)	ASD-CAPW110X
Power Connector	ASD-CAPW1000
Incremental Type Encoder Cable	ASD-CAEN100X
Absolute Type Encoder Cable	ASD-A2EB100X
Encoder Connector	ASD-CAEN1000

(X=3 indicates that the cable length is 3m; X=5 indicates that the cable length is 5m)

## 1.5kW Servo Drive and 1.3kW Medium-High Inertia Servo Motor

Servo Drive	ASD-A2-1543-□
Medium-High Inertia Servo Motor	ECMA-L△1313□S
Motor Power Cable (Without Brake)	ASD-CAPW100X
Motor Power Cable (With Brake)	ASD-CAPW110X
Power Connector	ASD-CAPW1000
Incremental Type Encoder Cable	ASD-CAEN100X
Absolute Type Encoder Cable	ASD-A2EB100X
Encoder Connector	ASD-CAEN1000

(X=3 indicates that the cable length is 3m; X=5 indicates that the cable length is 5m)

## 1.5kW Servo Drive and 1.5kW Medium Inertia Servo Motor

Servo Drive	ASD-A2-1543-□
Medium Inertia Servo Motor	ECMA-K△1315□S
Motor Power Cable (Without Brake)	ASD-CAPW100X
Motor Power Cable (With Brake)	ASD-CAPW110X
Power Connector	ASD-CAPW1000
Incremental Type Encoder Cable	ASD-CAEN100X
Absolute Type Encoder Cable	ASD-A2EB100X
Encoder Connector	ASD-CAEN1000

(X=3 indicates that the cable length is 3m; X=5 indicates that the cable length is 5m)

## 2kW Servo Drive and 2kW Low Inertia Motor

Servo Drive	ASD-A2-2043-□
Low Inertia Servo Motor	ECMA-J△1020□S
Motor Power Cable (Without Brake)	ASD-CAPW120X
Motor Power Cable (With Brake)	ASD-CAPW130X
Power Connector	ASD-CAPW1000
Incremental Type Encoder Cable	ASD-CAEN100X
Absolute Type Encoder Cable	ASD-A2EB100X
Encoder Connector	ASD-CAEN1000

(X=3 indicates that the cable length is 3m; X=5 indicates that the cable length is 5m)

## 2kW Servo Drive and 2kW Medium Inertia Servo Motor

Servo Drive	ASD-A2-2043-□
Medium Inertia Servo Motor	ECMA-K△1320□S
Motor Power Cable (Without Brake)	ASD-CAPW120X
Motor Power Cable (With Brake)	ASD-CAPW130X
Power Connector	ASD-CAPW1000
Incremental Type Encoder Cable	ASD-CAEN100X
Absolute Type Encoder Cable	ASD-A2EB100X
Encoder Connector	ASD-CAEN1000

(X=3 indicates that the cable length is 3m; X=5 indicates that the cable length is 5m)

## 2kW Servo Drive and 2kW Medium Inertia Servo Motor

Servo Drive	ASD-A2-2043-□
Medium Inertia Servo Motor	ECMA-K△1820□S
Motor Power Cable (Without Brake)	ASD-CAPW220X
Motor Power Cable (With Brake)	ASD-CAPW230X
Power Connector	ASD-CAPW2000
Incremental Type Encoder Cable	ASD-CAEN100X
Absolute Type Encoder Cable	ASD-A2EB100X
Encoder Connector	ASD-CAEN1000

(X=3 indicates that the cable length is 3m; X=5 indicates that the cable length is 5m)

## 3kW Servo Drive and 3kW Medium-Low Inertia Servo Motor

Servo Drive	ASD-A2-3043-□
Medium-Low Inertia Servo Motor	ECMA-J△1330□4
Motor Power Cable(Without Brake)	ASD-CAPW120X
Motor Power Cable (With Brake)	ASD-CAPW130X
Power Connector	ASD-CAPW1000
Incremental Type Encoder Cable	ASD-CAEN100X
Absolute Type Encoder Cable	ASD-A2EB100X
Encoder Connector	ASD-CAEN1000

(X=3 indicates that the cable length is 3m; X=5 indicates that the cable length is 5m)

## 3kW Servo Drive and 3kW Medium-High Inertia Servo Motor

Servo Drive	ASD-A2-3043-□
Medium-High Inertia Servo Motor	ECMA- L△11830□S
Motor Power Cable (Without Brake)	ASD-CAPW220X
Motor Power Cable (With Brake)	ASD-CAPW230X
Power Connector	ASD-CAPW2000
Incremental Type Encoder Cable	ASD-CAEN100X
Absolute Type Encoder Cable	ASD-A2EB100X
Encoder Connector	ASD-CAEN1000

(X=3 indicates that the cable length is 3m; X=5 indicates that the cable length is 5m)

## 4.5kW Servo Drive and 4.5kW Medium-High Inertia Servo Motor

Servo Drive	ASD-A2-4543-□
Medium-High Inertia Servo Motor	ECMA-L△1845□S
Motor Power Cable (Without Brake)	ASD-CAPW220X
Motor Power Cable (With Brake)	ASD-CAPW230X
Power Connector	ASD-CAPW2000
Incremental Type Encoder Cable	ASD-CAEN100X
Absolute Type Encoder Cable	ASD-A2EB100X
Encoder Connector	ASD-CAEN1000

(X=3 indicates that the cable length is 3m; X=5 indicates that the cable length is 5m)

## 5.5kW Servo Drive and 5.5kW Medium-High Inertia Servo Motor

Servo Drive	ASD-A2-5543-□
Medium-High Inertia Servo Motor	ECMA-L11855□3
Motor Power Cable (Without Brake)	ASD-CAPW220X
Motor Power Cable (With Brake)	ASD-CAPW230X
Power Connector	ASD-CAPW2000
Incremental Type Encoder Cable	ASD-CAEN100X
Absolute Type Encoder Cable	ASD-A2EB100X
Encoder Connector	ASD-CAEN1000

(X=3 indicates that the cable length is 3m; X=5 indicates that the cable length is 5m)

## 7.5kW Servo Drive and 7.5kW Medium-High Inertia Servo Motor

Servo Drive	ASD-A2-7543-□
Medium-High Inertia Servo Motor	ECMA-L11875□3
Motor Power Cable (Without Brake)	ASD-CAPW320X
Motor Power Cable (With Brake)	ASD-CAPW330X
Power Connector	ASD-CAPW2000
Incremental Type Encoder Cable	ASD-CAEN100X
Absolute Type Encoder Cable	ASD-A2EB100X
Encoder Connector	ASD-CAEN1000

(X=3 indicates that the cable length is 3m; X=5 indicates that the cable length is 5m)

 **NOTE**

1. The boxes (□) at the ends of the servo drive model names. For the actual model name, please refer to the ordering information of the actual purchased product.
2. The boxes (△) in the model names are for encoder resolution types. Please refer to Chapter 1 for further information.
3. The boxes (□) in the model names represent brake or keyway / oil seal.

### ■ Other Accessories (for ASDA-A2 series all models)

Description	Delta Part Number
50Pin I/O signal connector (CN1)	ASD-CN5C0050
Terminal Block Module	ASD-BM-50A
RS-232 Communication Cable	ASD-CARS0003
Communication Cable between Drive and Computer (for PC)	DOP-CAUSBAB
CANopen Communication Cable	TAP-CB03/TAP-CB05
CANopen Distribution Box	TAP-CN03
RS-485 Connector	ASD-CNIE0B06
Regenerative Resistor 400W 40Ω	BR400W040
Regenerative Resistor 1kW 20Ω	BR1K0W020
Regenerative Resistor 1.5kW 5Ω	BR1K5W005

# Appendix B Maintenance and Inspection

## Basic Inspection

Item	Content
General inspection	Periodically check if the screws of the servo drive, the connection between the motor shaft and the mechanical system as well as the connection of terminal block and mechanical system are securely tightened.
	The gap of the control chamber and the installation of the cooling fan should free from oil, water or metallic particles. Also, the servo drive shall free from the cutting power of the power drill.
	If the control chamber is installed in the site which contains harmful gas or full of dust, please be ensured the servo drive is free from the harmful gas and dust.
	When making encoder cable or wire rods, please be ensured the wiring is correct. Otherwise, the motor may have sudden unintended acceleration or be burned.
Inspection before operation (has not applied to the power yet)	To avoid the electric shock, the ground terminal of the servo drive should firmly connect to the ground terminal of the control chamber. If the wiring is needed, wait at least 10 minutes after disconnecting the drive from the main supply power, or discharge electricity by discharge device.
	The splicing parts of the wiring terminal should be isolated.
	Make sure the wiring is correct so as to avoid the damage or any abnormality.
	Check if the electric conductivity objects including sheetmetal (such as screws) or inflammable objects are not inside the servo drive.
	Check if the control switch is in OFF status.
	Do not place the servo drive of external regenerative resistor on inflammable objects.
	To avoid the electromagnetic brake losing efficacy, please check if stop function and circuit break function can work normally.
	If the peripheral devices are interfered by the electronic instruments, please reduce electromagnetic interference with devices.
Inspection before	The encoder cable should avoid excessive stress. When the motor is running, please be ensured the cable is not frayed or over extended.



running the servo drive (has already applied to the power)	Please contact with Delta if there is any vibration of the servo motor or unusual noise during the operation.
	Make sure the setting of the parameters is correct. Different machinery has different characteristic, please adjust the parameter according to the characteristic of each machinery.
	Please reset the parameter when the servo drive is in the status of SERVO OFF, or it may cause malfunction.
	When the relay is operating, make sure it can work properly.
	Check if the power indicator and LED display works normally.

## Maintenance

- Please use and store the product in a proper site.
- Periodically clean the surface of the servo drive and servo motor so as to avoid the dust and dirt.
- Do not disassemble any mechanical part when in maintenance.
- Periodically clean the ventilation ports of the servo drive and do not use the product in a high-temperature site for a long time so as to avoid the malfunction.

## The lifetime of machinery parts

- DC Bus Capacitor  
DC Bus Capacitor will be deteriorated by the affection of ripple current. Its lifetime is determined by the surrounding temperature and operating conditions. If it is operating in an air-conditioned site, its lifetime can up to 10 years.
- Relay  
The contact of switching power supply will wear and leads to poor contact. The lifetime of relay is influenced by the power supply capacity; thus, the accumulative time of switching power supply is about 100,000 times.
- Cooling Fan  
In continuous operation, the lifetime of the cooling fan is 2 to 3 years. However, if there is any unusual noise or vibration during inspection, place a new one is a must.